



PIEDMONT
ENVIRONMENTAL
ASSOCIATES, P.A.

May 12, 2021
REVISED 8/20/21

Chatham County Environmental Health
c/o: Mr. Thomas Boyce, L.S.S.
80 East St. D
Pittsboro, NC 27312

Mr. Boyce,

I have reviewed a proposed subdivision plan for the Pyewacket subdivision, Chatham County parcel number 0090267.

Attachment 1 shows the original soil and site suitability map and report that was performed on this tract. The project engineer then provided a subdivision plan which was overlain with our soil data (Attachment 2).

Attachment 3 provides a table with square footages of suitable soils for each of the 92 proposed lots. As shown in Attachment 2, the amount of suitable soil ranged from +/-5,000 – 21,000 square feet, which should provide sufficient space for a treatment system with repair.

Some lots did not have conventional soils on site. These lots will be served by offsite layout areas. It should be noted that engineered flow reductions will be utilized for these lots. The suitable soil per system in these offsite areas ranged from +/-8,500 – 11,000 square feet, which should provide sufficient space for a treatment system with repair.

If you have any further questions, please feel free to contact me at (336) 662-5487. I will be happy to provide further clarification if necessary.

Sincerely,



G. Christopher Murray
NC Licensed Soil Scientist #1284
Piedmont Environmental Associates, PA

216 S. Swing Rd, Suite 1 • Greensboro, NC 27409 • 336-662-5487

List of Attachments:

Attachment 1 - Original Map and Report

Attachment 2 - Overall Site Map

Attachment 3 - Soil Area Totals Table

Attachment 4 – Utilities Map from Project Engineer Showing Soil Areas



PIEDMONT
ENVIRONMENTAL
ASSOCIATES, P.A.

12/14/20

Project # 2112

Jones Ferry Project (Merritt Tract)
c/o: Warren Mitchell
104 Amber Wood Run
Chapel Hill, NC 27516

RE: Detailed Soil/Site Evaluation on Property Located off of Jones Ferry Road, Parcel Number 0090267(Chatham)/ 9757513504(Orange)

Mr. Mitchell,

This report details the findings of a detailed site and soil evaluation performed on the tract referenced above. The evaluation was conducted at the clients written request in order to determine the site's suitability for the installation of sub-surface wastewater disposal systems to serve domestic strength wastewater. This evaluation was for residential strength wastewater applications. Any other type of use may require additional testing and/or stricter setbacks. This report does not address systems receiving more than 3,000 gallons per day of flow.

The evaluation was conducted by Chris Murray, Ryan Smith, Jim Beeson and Edwin Stott, North Carolina Licensed Soil Scientists, in December, 2020. The evaluation was conducted during moist soil conditions with the use of a hand-auger to determine soil suitability for on-site sewage disposal systems in accordance with 15A NCAC 18A .1900 "Laws and Rules for Sewage Treatment and Disposal Systems". Characteristics that affect the suitability of sub-surface systems include soil depth to expansive clay, seasonal high-water table, rock, and unusable saprolite. Topography and slope also affect the suitability of an area for septic systems. The evaluation of these components was conducted on the site. The level of the evaluation was detailed for this tract.

Findings are conveyed by showing areas on the enclosed map that are usable for different system types. Areas that are suitable for conventional depth wastewater systems are hatched in red. These areas have usable topography and a minimum slope-corrected soil depth of 24 inches. Areas that are suitable for low profile chamber depth wastewater systems (which require more space) are hatched in orange. These areas have usable topography and a minimum slope-corrected soil depth of 21 inches. All hatched areas are generated using gps technology in the field and are not survey located. The areas are labeled with approximate square footages.

Once the soils map is complete the size of area required for a septic system can be estimated. Residential systems are sized according to the number of bedrooms in the proposed dwelling. Systems are not sized based on the number of bathrooms in the

dwelling. Each bedroom in the proposed dwelling is calculated to generate a daily flow of 120 gallons. A four-bedroom dwelling would have a daily calculated flow of 480 gallons. The daily flow is divided by the loading rate based on the soil texture. This site has a clay texture so would have an estimated long-term acceptance rate (LTAR) of 0.25 gallons per square foot of trench bottom per day. The minimum required area or square footage on the ground for the primary septic system and the repair area with this LTAR for the conventional hatched areas would be approximately 10,000 – 12,000 square feet. The minimum required area or square footage on the ground for the primary septic system and the repair area with this LTAR for the low profile chamber hatched areas would be approximately 13,000 – 16,000 square feet. These areas must meet all setbacks from property lines, wells, water lines and structures as well as any other easement imposed by other entity. All lots will require an application and evaluation by the county health department on an individual basis.

This report discusses the general location of potentially usable soils for on-site wastewater disposal and the soil and site limitations on the property that exists at the time of the evaluation. Piedmont Environmental Associates, PA (“Piedmont”) provides professional consulting specializing in the practice of soil science and wastewater management. Piedmont is therefore hired for its professional opinion regarding these matters. Laws and rules governing wastewater treatment and disposal are forever evolving and subject to the interpretation and opinion of individuals which are employed by local and state agencies that govern these laws and rules. Due to this fact, Piedmont cannot guarantee in any way that any area located in the field, shown on a sketch, or discussed with the client will be permitted by any of these agencies. It is for this reason that **Piedmont strongly recommends to anyone considering a financial commitment on any piece of property be completely aware of any and all permit requirements on that property before purchase and obtain those permits prior to a final financial commitment.**

We are pleased to be of service in this matter. If you have any further questions, please feel free to call (336) 662-5487.

Sincerely,



G. Christopher Murray
NC Licensed Soil Scientist #1284
Piedmont Environmental Associates, PA

Attachment I

.1950 Location of Sanitary Sewage Systems

- (c) Every sanitary sewage treatment and disposal system shall be located at least the minimum horizontal distance from the following:
- | | |
|---|----------|
| (1) Any private water supply source including a well or spring | 100 feet |
| (2) Any public water supply source | 100 feet |
| (3) Streams classified as WS-I | 100 feet |
| (4) Water classified as S.A.
from mean high water mark | 100 feet |
| (5) Other coastal waters
from mean high water mark | 50 feet |
| (6) Any other stream, canal, marsh, or other surface waters | 50 feet |
| (7) Any Class I or Class II reservoir
from normal pool elevation | 100 feet |
| (8) Any permanent storm water retention pond
from flood pool elevation | 50 feet |
| (9) Any other lake or pond
from normal pool elevation | 50 feet |
| (10) Any building foundation | 5 feet |
| (11) Any basement | 15 feet |
| (12) Any property line | 10 feet |
| (13) Top of slope of embankments or cuts of 2 feet or more
vertical height | 15 feet |
| (14) Any water line | 10 feet |
| (15) Drainage systems: | |
| (A) Interceptor drains, foundation drains and storm water diversions | |
| (i) upslope | 10 feet |
| (ii) sideslope | 15 feet |
| (iii) downslope | 25 feet |
| (B) Groundwater lowering ditched and devices | 25 feet |
| (16) any swimming pool | 15 feet |
| (17) any other nitrification field (except repair area) | 20 feet |
- (b) Ground absorption, sewage treatment and disposal systems may be located closer than 100 feet from a private well supply, except springs and uncased wells located downslope and used as a source of drinking water, repairs, space limitations and other site-planning considerations but shall be located the maximum feasible distance and, in no case, less than 50 feet.
- (c) Nitrification fields and repair areas shall not be located under paved areas or areas subject to vehicular traffic. If effluent is to be conveyed under areas subject to vehicular traffic, ductile iron or its equivalent pipe shall be used. However, pipe specified in Rule .1955 (e) may be used if a minimum of 30 inches of compacted cover is provided over the pipe.

Note: Systems over 3000 GPD or an individual nitrification fields with a capacity of 1500 GPD or more have more restrictive setback requirements, see .1950 (a) (17) (d) for specifics.

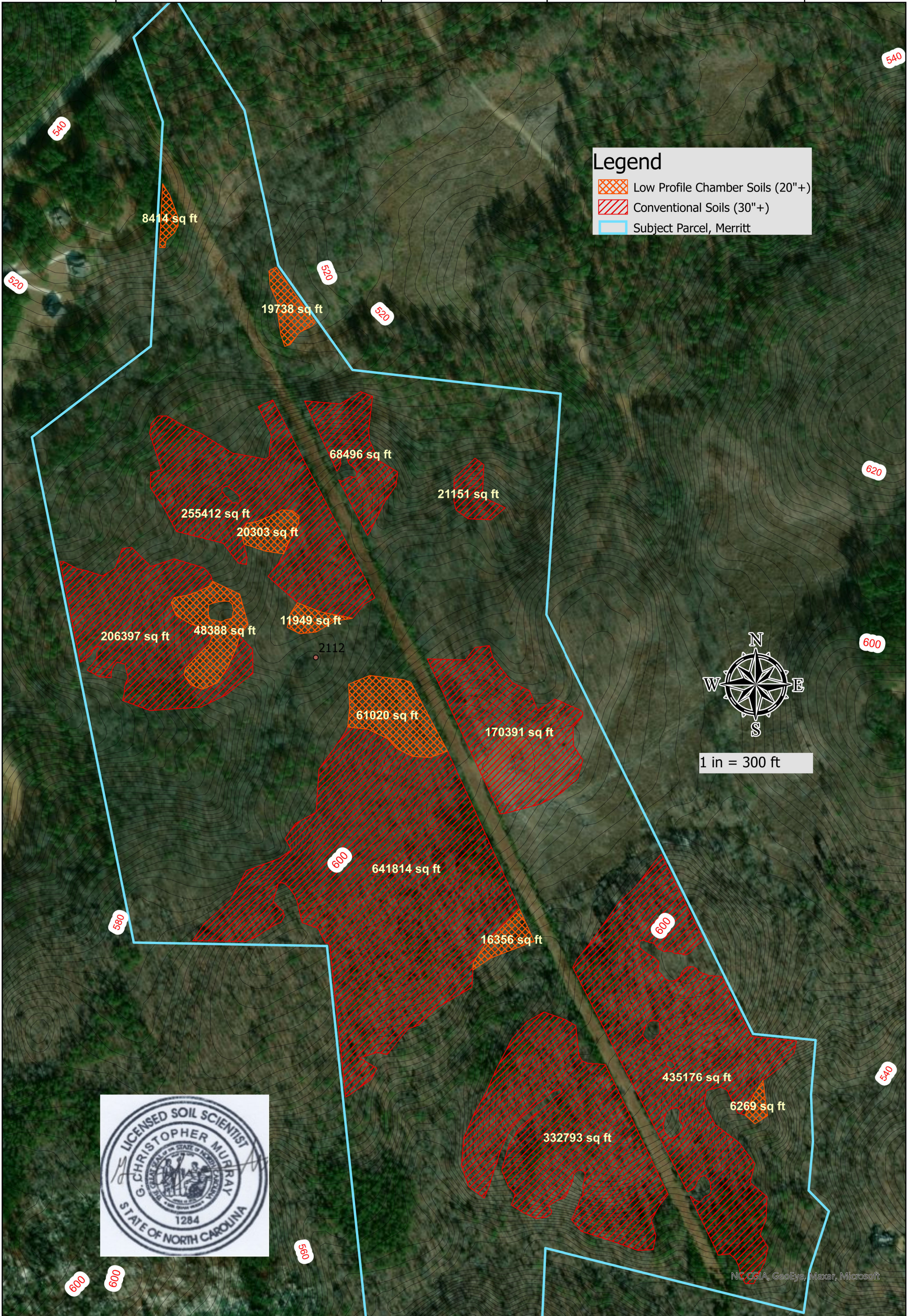

1 in = 300 ft

pyewacket subdivision

conservation subdivision
 chatham county, nc
 November 19, 2021

Layout 3 UTILITY PLAN

SITE DATA

Owner: Wyndell H. Merritt
 Address: Jones Ferry Road
 Parcel ID: 90267
 Zoning: R1
 Parcel Size: 139.63 acres
 Orange County = 11.24 acres
 proposed lots = 0
 Chatham County: (gross ac)=128.391 acres
 Floodplain = 0.95 acres
 Streams = 0.50 acres
 total lots allowed:
 128.391-0.95-0.50 = 126.941 acres
 126.941 / .918(40,000sf) = 138.2 lots
 138.2 x 1.1 = 152 lots
 total lots proposed = 93
 maximum lot size: +/- 1.0 ac
 minimum lot size: +/- 0.42 ac
 average lot size: +/- 0.6 ac
 length of roads: [Chatham]+/- 7200 LF (60' public r/w)
 [Orange] +/- 1480 LF (60' public r/w)
 Roads - public. Area within road r/w: +/- 12.1 ac
 Steep slopes: 0 acres
 Water provided by Community Well
 Sewer provided by private septic systems

Plan prepared by:
 Warren D. Mitchell, PE
 104 Amber Wood Run
 Chapel Hill, NC 27516
 warrendmitchellpe@gmail.com
 919-593-1916

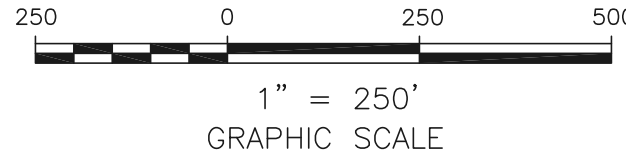

CONSERVATION SPACE

Conservation Space Required = 40%
 128.391 ac x 0.4 = 51.35 acres
 Natural Space Required = 32%
 128.391 ac x 0.32 = 41.08 acres
 Open Space Required = 8.0%
 128.391 ac x 0.08 = 10.27 acres
Total Conservation Space Provided:
Chatham County
 Natural Space Provided = 41.50 ac (32%)
 Open Space Provided = 20.1 ac (15.6%)
 Total Conservation Space Provided = 61.60 ac
 Conservation Space = 48% of total site area
Orange County
 Conservation Space Provided = 9.24 acres
TOTAL FOR CHATHAM AND ORANGE COUNTIES
 61.60 ac + 9.24 ac = 70.84 acres
 70.84 / 139.63 acres = 50.7% Conservation Space

Notes:

- rustic trails (no concrete or asphalt) may be provided within the natural space. Trail line shown is approximate and for visual aid only.
- stormwater ponds located inside open space.
- community wells are located inside open space.
- common septic systems located inside open space.

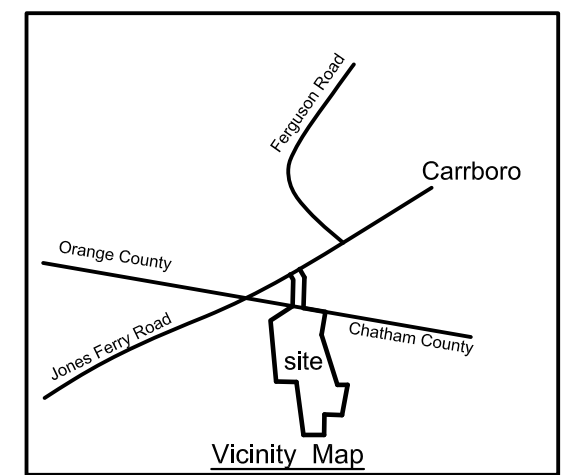

LEGEND

- Conservation Natural Space
- Conservation Open Space
- Orange County Open Space
- Perennial Streams
- Intermittent Streams
- Ephemeral Streams
- Wetlands
- Stream + Wetland Buffer
- Offsite Septic Fields
- Stormwater Basin
- Septic Field Area

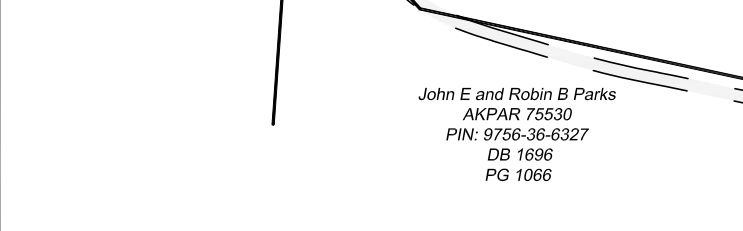
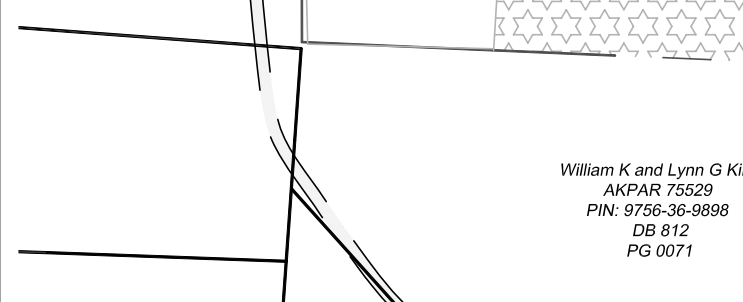
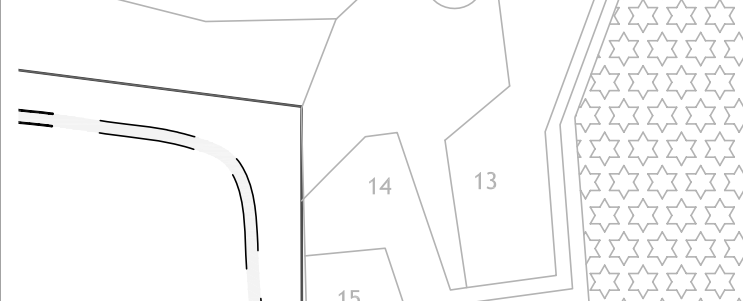
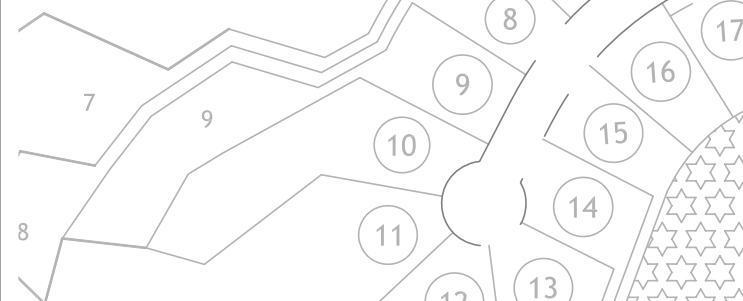
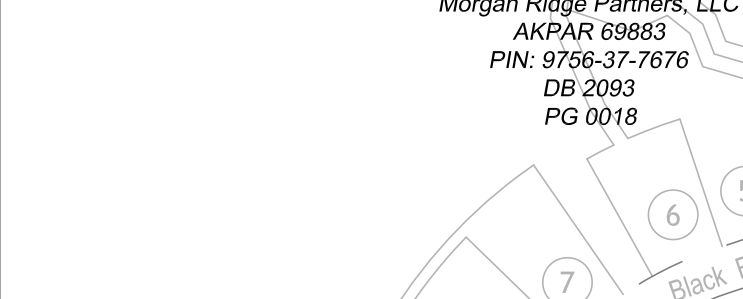
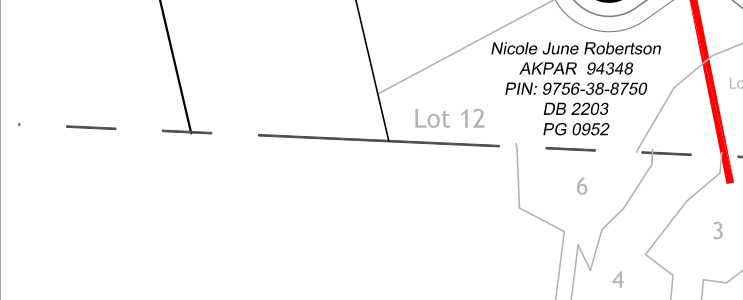
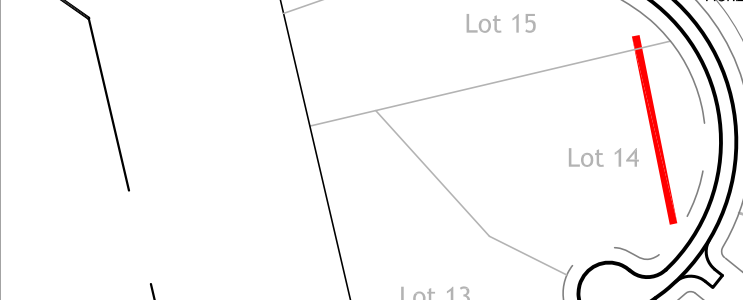
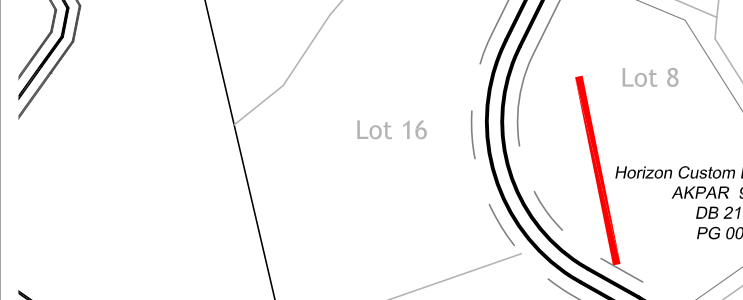
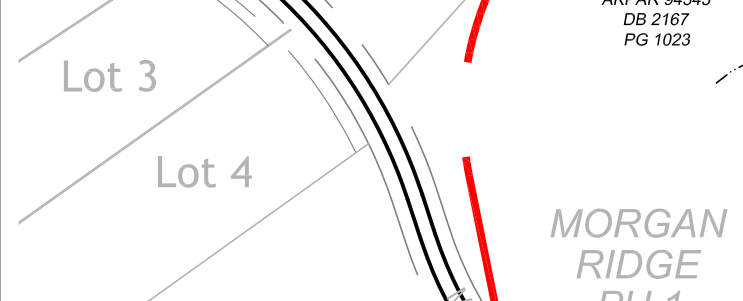
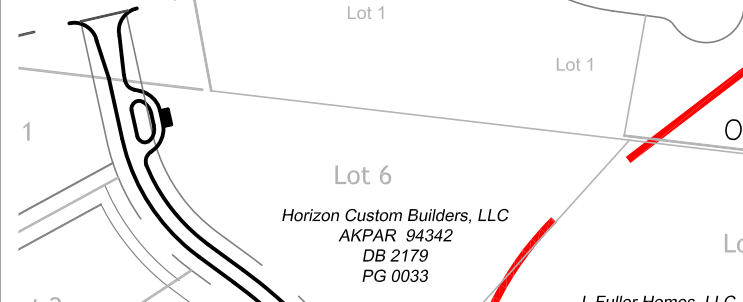
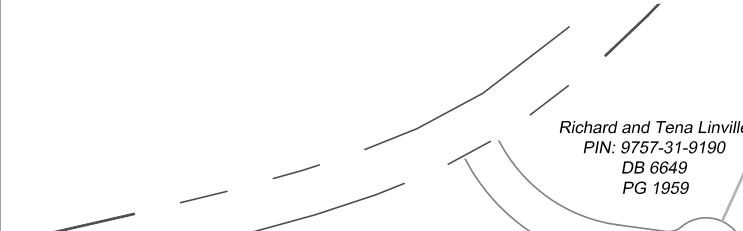
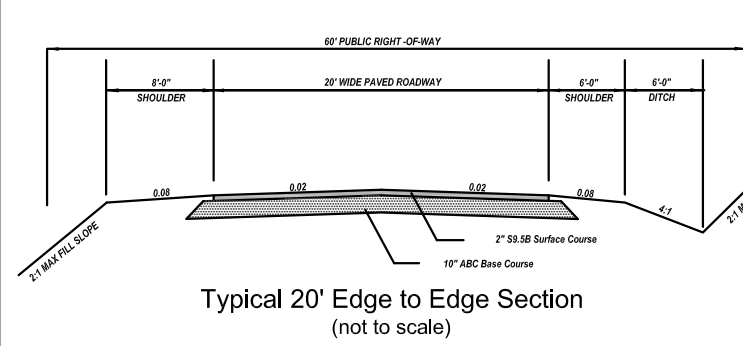
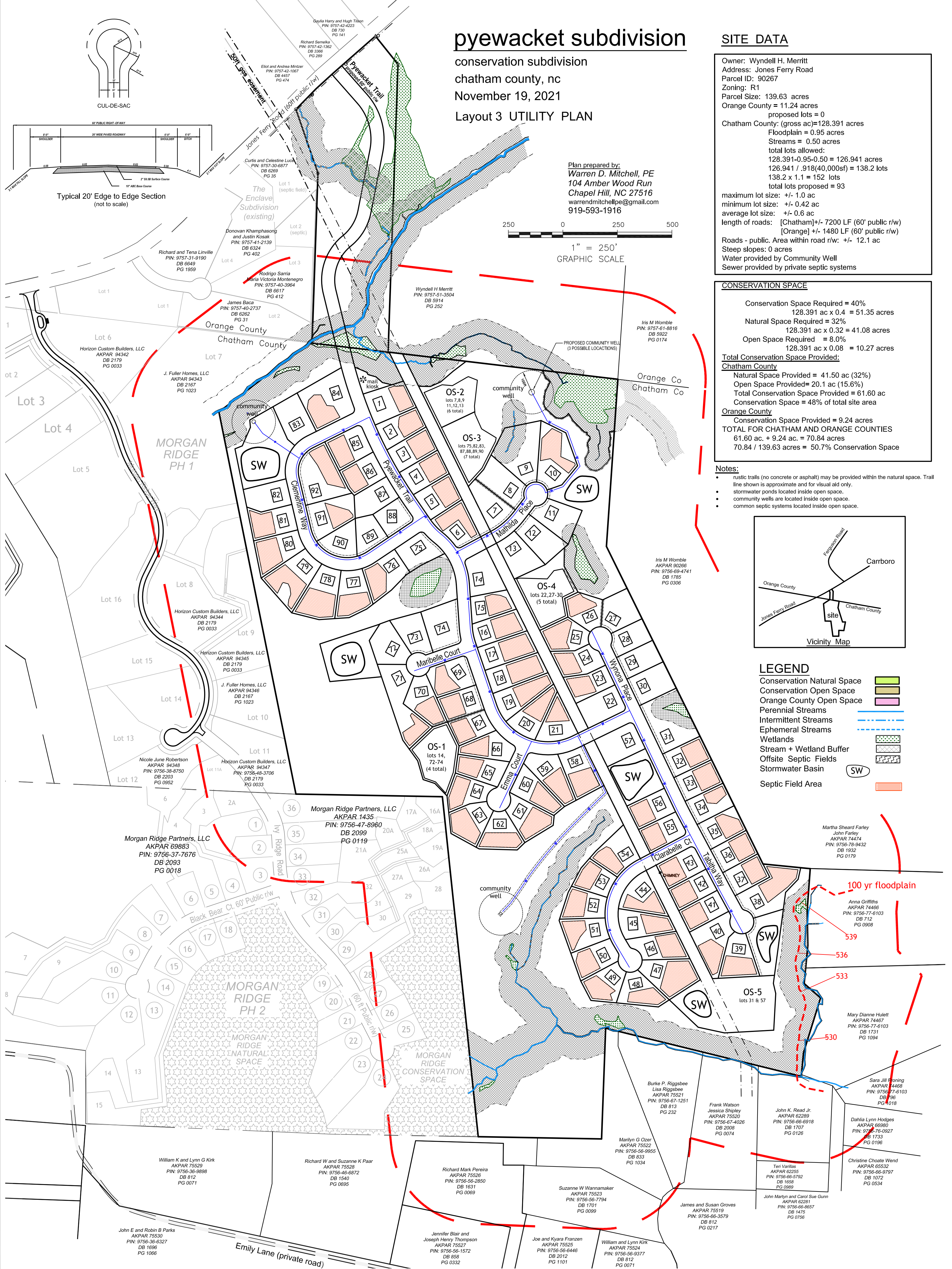

**Attachment 3 - Soil Area Totals, Pyewacket S/D,
Chatham County, NC (REV., August 2021)**

Lot #	Soil Areas (sq ft)	
	Conv	LPC
1	7956	-
2	8755	-
3	9604	-
4	9219	-
5	9453	-
6	12344	-
7 (offsite)	Served by OS 1	
8 (offsite)		
9	7541	-
10	8422	-
11 (offsite)	Served by OS 2	
12 (offsite)		
13	7867	-
14	10162	-
15	9717	-
16 (offsite)	Served by OS 2	
17 (offsite)		
18	9167	-
19	9396	-
20 (offsite)	Served by OS 2	
21 (offsite)		
22	14779	-
23 (offsite)	Served by OS 1	
24 (offsite)		
25 (offsite)		
26	8428	-
27	7350	-
28 (offsite)	Served by OS 3	
29 (offsite)		
30 (offsite)		
31	10490	-
32 (offsite)	Served by OS 4	
33 (offsite)		
34 (offsite)		
35 (offsite)		
36 (offsite)	Served by OS 5	
37	-	7993
38	-	10825
39	-	12468
40	12931	-
41	10850	-
42	8879	-
43	4937	-
44 (offsite)	Served by OS 5	
45 (offsite)		
46 (offsite)		
47 (offsite)		
48 (offsite)		
49	7197	-
50	8849	-
51	9722	-
52	10524	-
53	10300	-
54	10990	-
55	11975	-
56	-	9475
57 (offsite)	Served by OS 6	
58 (offsite)		
59	8590	-
60	8321	-
61	12999	-
62	9980	-

Lot #	Soil Areas (sq ft)		
	Conv	LPC	
63 (offsite)	Served by OS 6		
64 (offsite)			
65 (offsite)			
66 (offsite)			
67 (offsite)			
68			
69	7369	-	
70	7131	-	
71	3989	-	
72	7313	-	
73	7107	-	
74	6235	-	
75	21889	-	
76	10756	-	
77	8439	-	
78	8519	-	
79	9299	-	
80	9846	-	
81	9776	-	
82	10561	-	
83	17589	-	
84	7257	-	
85	8972	-	
86	8376	-	
87	6784	-	
88	8717	-	
89	7381	-	
90	8350	-	
91	8333	-	
92	8513	-	
OS 1 - Lots 7,8,23,24,25*	47000	-	5
OS 2 - Lots 11,12,16,17,20,21*	57000	-	6
OS 3 - Lots 28,29,30*	33000	-	3
OS 4 - Lots 32,33,34,35*	34000	-	4
OS 5 - Lots 36,44,45,46,47,48*	54600	-	6
OS 6 - Lots 57,58,63,64,65,66,67*	72000	-	7

*8-10,000 SF of suitable soil is provided in these offsite areas for each 240 GPD residence