

PROPERTY OWNERS							
PARCEL	OWNER	PIN	DB	PG	MB	PG	ZONING
1	JOSEPH L. LIRETTE JR., & VENESSA ANNE LIRETTE	84671.00	2016	280	2006	446	R-1
2	LARRY G. WRIGHT & JOY V WRIGHT	84670.00	2033	811	2006	446	R-1
3	KEITH DALE & MAUREEN DALE	84669.00	2052	400	2006	446	R-1
4	TRIPLE A HOMES, INC.	84668.00	2046	1124	2006	445	R-1
5	SAGE BUILD, LLC.	84667.00	1834	611	2006	445	R-1
6	SAGE BUILD, LLC.	84666.00	1834	611	2006	445	R-1
7	BEVERLY ANN DUGAN & PATRICK JOSEPH MAHONEY	84657.00	1984	346	2006	446	R-1
8	THOMAS FREIDL & CHARLENE WIWEL	84657.00	1984	346	2007	451	R-1
9	MICHAEL JANISON & DEBORAH JANISON	84656.00	1820	231	2006	445	R-1
10	CINTIA C. ALCALA & MICHAEL V. FARRELL	84655.00	1858	340	2006	445	R-1
11	RICH A ACKER & REBECCA S ACKER	84741.00	1541	1183	2006	445	R-1
12	EMANUELA BAR & ALLEN SHORTELL	84740.00	1580	124	2002	124	R-1

SITE DATA	
OWNER:	SWAIN LAND & TIMBER, LLC
DEVELOPER:	SWAIN LAND & TIMBER, LLC
DEVELOPER ADDRESS:	117 EDINBURG SOUTH DR STE 101, CARY, NC 27511
DEVELOPER PHONE NUMBER:	(919) 417-2990
SUBDIVISION NAME:	MCBANE PARK
SITE ADDRESS:	OLD GRAHAM RD
DEED BOOK: 1659	PAGE: 1161
AKPAR NUMBER:	85448.00
SITE AREA:	161.97 ACRES
CURRENT ZONING:	R-1
WATERSHED:	JORDAN LAKE
WATERSHED DISTRICT:	WS-IV PA
TOTAL LOTS ALLOWED:	149
TOTAL LOTS PROPOSED:	149
AVERAGE LOT SIZE:	±22,000 SF
MINIMUM LOT SIZE:	±12,500 SF
LENGTH OF ROAD:	±10,500 LF

CONSERVATION SPACE	
TYPE	AREA
TOTAL MINIMUM CONSERVATION SPACE REQUIRED (40% OF SITE AREA)	64.79 AC
MINIMUM NATURAL SPACE REQUIRED (80% OF CONSERVATION SPACE)	51.83 AC
NATURAL SPACE PROVIDED**	53.05 AC
DEDICATED OPEN SPACE PROVIDED* (MAX 20% OF CONSERVATION SPACE)	12.75 AC
VOLUNTARY NATURAL SPACE PROVIDED	3.70 AC
TOTAL NATURAL SPACE PROVIDED	56.75 AC
STEEP SLOPES OF PROPERTY	0.0 SF

* STORMWATER PONDS LOCATED INSIDE OPEN SPACE
 ** RUSTIC TRAILS (NO CONCRETE OR ASPHALT) MAY BE PROVIDED WITHIN THE NATURAL SPACE. TRAIL LINE SHOWN IS APPROXIMATE AND FOR VISUAL AID ONLY.

LINE TABLE			LINE TABLE			LINE TABLE		
LINE	BEARING	DISTANCE	LINE	BEARING	DISTANCE	LINE	BEARING	DISTANCE
L286	N18°05'46"E	455.95'	L306	S34°08'14"W	54.23'	L326	S71°07'22"W	86.00'
L287	N18°05'46"E	172.32'	L307	S34°08'14"W	17.23'	L327	S70°37'10"W	64.22'
L288	N18°05'45"E	11.34'	L308	S50°08'03"W	63.75'	L328	S70°12'36"W	80.56'
L289	S80°59'04"E	1817.46'	L309	S36°00'03"W	84.65'	L329	S80°59'26"W	38.83'
L290	N01°04'29"E	572.37'	L310	S30°47'13"W	49.53'	L330	S80°59'25"W	45.44'
L291	N01°04'29"E	723.72'	L311	S37°37'40"W	53.75'	L331	S73°08'56"W	79.23'
L292	N87°16'34"W	938.46'	L312	S41°22'24"W	69.68'	L332	S63°40'21"W	79.63'
L293	N86°40'44"W	1457.29'	L313	S29°30'35"W	22.43'	L333	N73°37'10"W	50.97'
L294	N03°33'45"E	552.56'	L314	S29°30'35"W	57.57'	L334	S74°05'35"W	41.34'
L295	N03°33'45"E	843.94'	L315	S80°34'22"W	87.08'	L335	S55°19'16"W	28.57'
L296	N03°33'45"E	726.03'	L316	S44°13'59"W	18.83'	L336	S61°06'04"W	57.77'
L297	N45°38'37"W	102.91'	L317	S44°14'00"W	76.83'	L337	S22°36'12"E	50.10'
L298	N55°09'16"W	91.43'	L318	S44°13'57"W	19.17'	L338	S22°40'40"E	60.69'
L299	N55°09'15"W	65.97'	L319	S66°11'31"W	41.21'	L339	S22°42'52"E	65.26'
L300	N75°22'25"W	115.58'	L320	S53°23'38"W	40.62'	L340	S22°42'26"E	65.80'
L301	S85°35'19"W	21.34'	L321	S82°48'08"W	53.21'	L341	S22°45'13"E	51.28'
L302	S86°36'10"W	29.59'	L322	S74°10'48"W	73.10'	L342	S22°49'06"E	55.44'
L303	S73°59'49"W	18.20'	L323	S70°37'37"W	68.56'	L343	S22°48'32"E	44.37'
L304	S35°07'31"W	34.99'	L324	S79°59'51"W	30.96'	L344	S22°59'39"E	29.44'
L305	S53°28'29"W	55.22'	L325	S79°59'51"W	25.45'	L345	S23°47'16"E	128.51'

LINE TABLE			LINE TABLE		
LINE	BEARING	DISTANCE	LINE	BEARING	DISTANCE
L346	S23°47'16"E	166.47'	L366	S51°53'29"E	13.51'
L347	S23°47'16"E	124.93'	L367	S53°22'04"E	13.61'
L348	S24°54'48"E	174.32'	L368	S55°00'59"E	20.60'
L349	S24°54'48"E	132.57'	L369	S57°46'15"E	30.22'
L350	S24°54'48"E	315.31'	L370	S62°58'36"E	14.55'
L351	S23°53'01"E	302.07'	L371	S62°04'08"E	1.99'
L352	S25°04'22"E	161.41'	L372	S62°04'04"E	16.31'
L353	S33°35'37"E	839.87'	L373	S63°57'01"E	24.65'
L354	S33°44'53"E	137.34'	L374	S66°38'19"E	47.69'
L355	S32°48'19"E	155.70'	L375	S70°40'02"E	60.80'
L356	S34°16'58"E	37.17'	L376	S72°33'03"E	55.73'
L357	S34°16'57"E	114.78'	L377	S74°44'28"E	70.34'
L358	S35°58'04"E	48.76'	L378	S73°32'43"E	71.49'
L359	S37°16'29"E	50.16'	L379	S72°59'12"E	23.85'
L360	S41°04'35"E	32.47'	L380	S72°59'11"E	1.63'
L361	S42°42'41"E	30.49'			
L362	S45°00'00"E	28.01'			
L363	S48°01'57"E	36.03'			
L364	S48°17'21"E	16.44'			
L365	S51°36'42"E	17.24'			

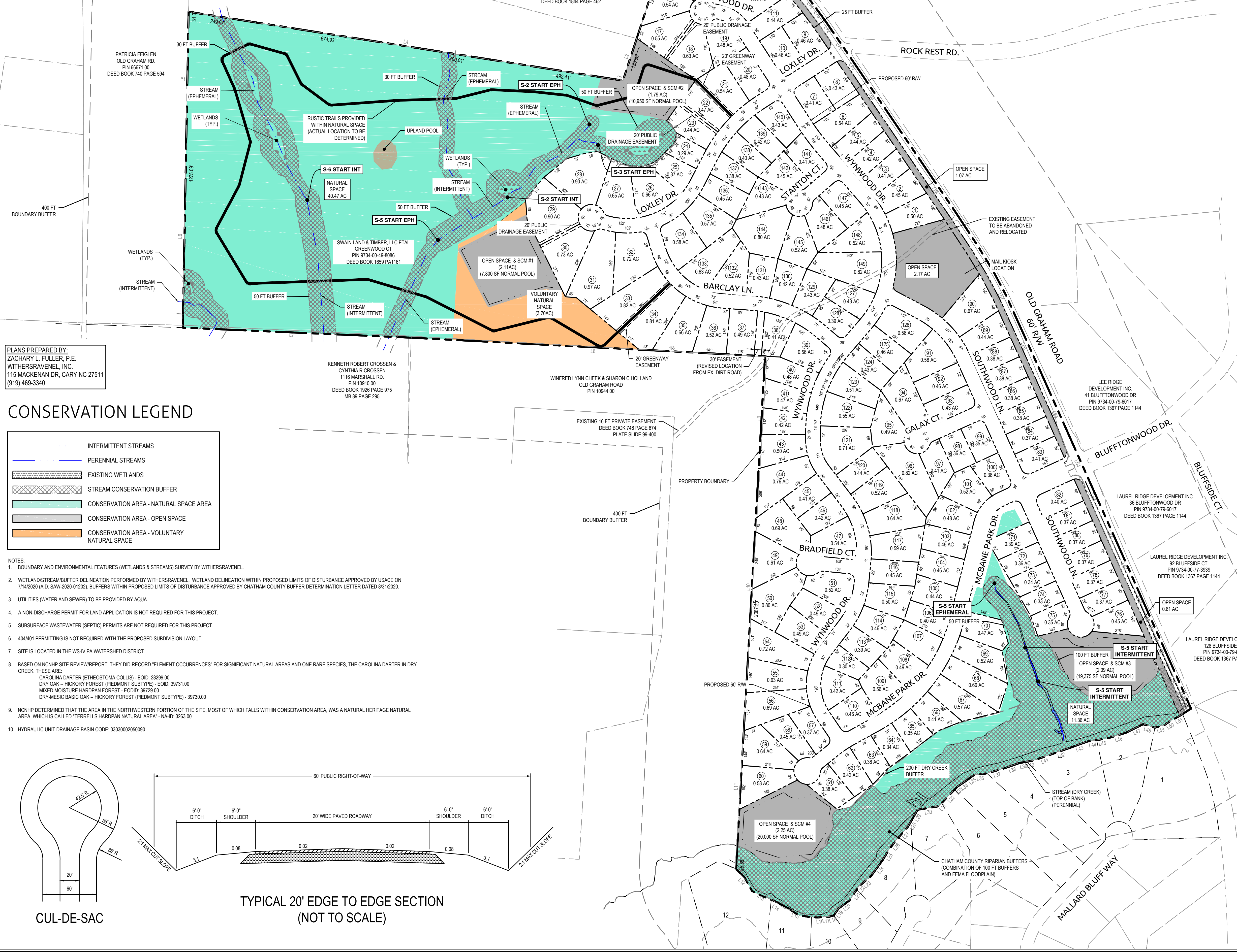

PLANS PREPARED BY:
 ZACHARY L. FULLER, P.E.
 WITHERSRAVENEL, INC.
 115 MACKENAN DR, CARY NC 27511
 (919) 469-3340

KENNETH ROBERT CROSSEN &
 CYNTHIA R CROSSEN
 1116 MARSHALL RD.
 PIN 10910.00
 DEED BOOK 1926 PAGE 975
 MB 89 PAGE 295

CONSERVATION LEGEND

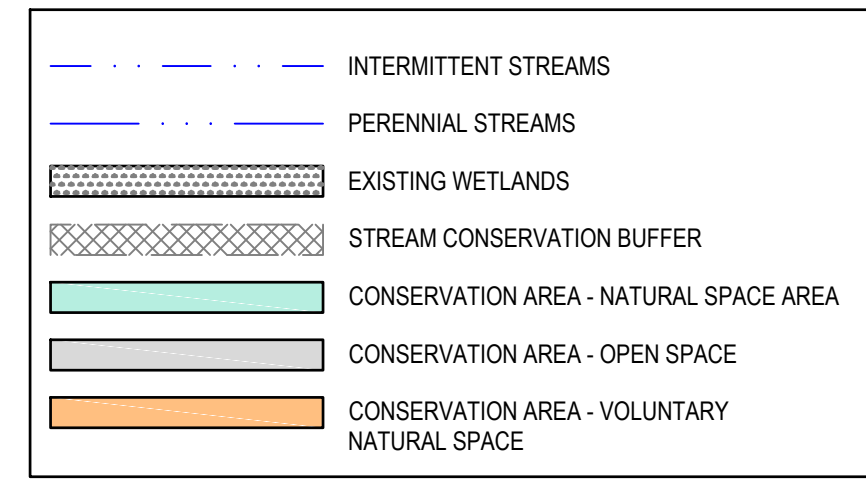

- NOTES:
- BOUNDARY AND ENVIRONMENTAL FEATURES (WETLANDS & STREAMS) SURVEY BY WITHERSRAVENEL.
 - WETLAND/STREAM/BUFFER DELINEATION PERFORMED BY WITHERSRAVENEL. WETLAND DELINEATION WITHIN PROPOSED LIMITS OF DISTURBANCE APPROVED BY USACE ON 7/14/2020 (AID: SAW-2020-01202). BUFFERS WITHIN PROPOSED LIMITS OF DISTURBANCE APPROVED BY CHATHAM COUNTY BUFFER DETERMINATION LETTER DATED 8/31/2020.
 - UTILITIES (WATER AND SEWER) TO BE PROVIDED BY AQUA.
 - A NON-DISCHARGE PERMIT FOR LAND APPLICATION IS NOT REQUIRED FOR THIS PROJECT.
 - SUBSURFACE WASTEWATER (SEPTIC) PERMITS ARE NOT REQUIRED FOR THIS PROJECT.
 - 404/401 PERMITTING IS NOT REQUIRED WITH THE PROPOSED SUBDIVISION LAYOUT.
 - SITE IS LOCATED IN THE WS-IV PA WATERSHED DISTRICT.
 - BASED ON NONHP SITE REVIEW/REPORT, THEY DID RECORD "ELEMENT OCCURRENCES" FOR SIGNIFICANT NATURAL AREAS AND ONE RARE SPECIES, THE CAROLINA DARTER IN DRY CREEK. THESE ARE:
 CAROLINA DARTER (ETHEOSTOMA COLLIS) - EODD: 28299.00
 DRY OAK - HICKORY FOREST (PIEDMONT SUBTYPE) - EODD: 39731.00
 MIXED MOISTURE HARDPAN FOREST - EODD: 39729.00
 DRY-MESIC BASIC OAK - HICKORY FOREST (PIEDMONT SUBTYPE) - 39730.00
 - NONHP DETERMINED THAT THE AREA IN THE NORTHWESTERN PORTION OF THE SITE, MOST OF WHICH FALLS WITHIN CONSERVATION AREA, WAS A NATURAL HERITAGE NATURAL AREA, WHICH IS CALLED "TERRELLS HARDPAN NATURAL AREA" - NA-ID: 3263.00
 - HYDRAULIC UNIT DRAINAGE BASIN CODE: 0303000205090

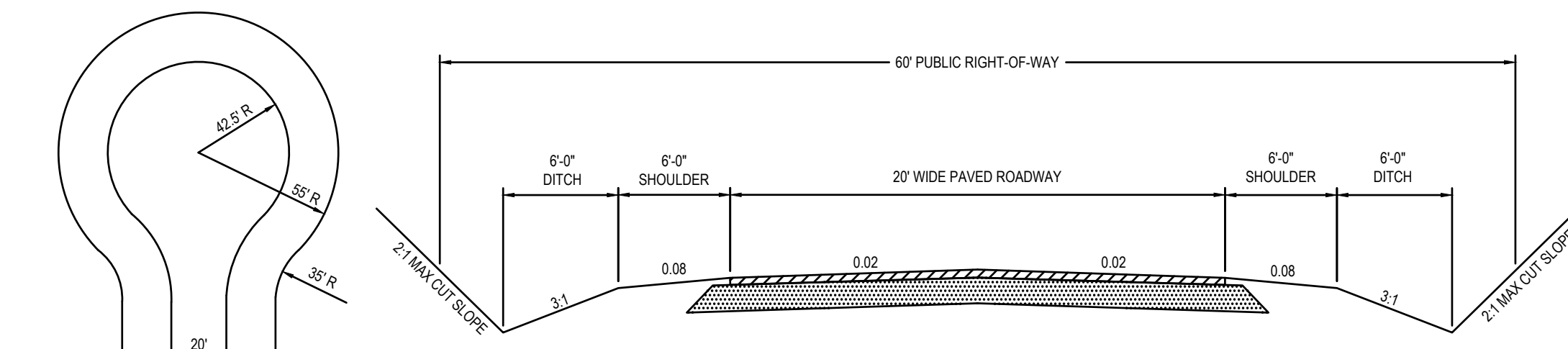

TYPICAL 20' EDGE TO EDGE SECTION (NOT TO SCALE)

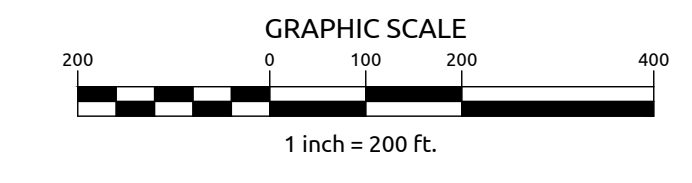

WithersRavenel
 Engineers | Planners

55 Grant Drive | Suite D | Pittsboro, NC 27312 | E: 919.469.3340 | License #: C-0682 | www.withersravenel.com

MCBANE PARK
 NORTH CAROLINA

CHATHAM COUNTY

FIRST PLAT

Job No.	02060411.02	Drawn By	WR
Date	04/16/21	Designer	WR

Revisions		
REV1	CHATHAM CNTY. COMMENTS	05/11/2021
REV2	TRC REVISIONS	05/19/2021
REV3	STREAM REVISIONS	05/21/2021
REV4	PLANNING REV.	06/22/2021

Sheet No.
1.0