

SEE PAGE 2 FOR APPURTENANCES

TOWER DESIGN CRITERIA

Design Standard: TIA-222-G*
 Design Wind Speeds: 122 mph (no ice) Vult per ASCE 7-16
 30 mph (0.75" ice)
 Service Wind Speed: 60 mph (deflection only)
 Structure Class: III
 Exposure Category: B
 Topographic Category: 1
 Crest Height: 0 ft
 Site Elevation: 0 ft. (NAVD 88)

MATERIAL STRENGTHS

Solid Rod A36 (rod dia. <3/4")
 A572 Gr.50 (3/4" thru 1" dia.)
 A572 Gr.58 (>1" dia. T10 - T18)
 A500 Gr.B (antenna pipes)
 A572 Gr.B/C (tower legs min. Fy 50 ksi)
 Pipe
 Angle A572 Gr.50
 Plate A572 Gr.50
 Bolts A-325/A-449 (leg & angle)
 Anchor Bolt F1554 Grade 105 or A687

Finish: Tower & Hardware are hot dip galvanized

- ALL STRUCTURAL HARDWARE IS GALVANIZED IN ACCORDANCE WITH ASTM A-153 (HDG). TOWER SECTIONS & ASSOCIATED STRUCTURAL COMPONENTS ARE GALVANIZED IN ACCORDANCE WITH ASTM A-123 (HDG).
- ALL BOLTS & NUTS MUST BE IN PLACE BEFORE ADJOINING SECTION(S) ARE INSTALLED.
- ALL STRUCTURAL BOLTS ARE TO BE TIGHTENED TO A SNUG TIGHT CONDITION AS DEFINED BY AISC & RCSC SPECIFICATION FOR STRUCTURAL JOINTS UNLESS NOTED OTHERWISE.
- ALL WELDING TO CONFORM TO AWS D1.1 SPECIFICATION. 5/16" MINIMUM WELD SIZE UNLESS NOTED OTHERWISE.
- MATERIAL LABELED AS ASTM A-572 GR. 58 OR 58 KSI YIELD STRENGTH ALSO CONFORMS TO ASTM A-572 GR. 50.
- ANALYSIS PERFORMED USING STEEL GRADES LISTED UNDER MATERIALS STRENGTHS SHOWN ON THIS PAGE.
- THIS DRAWING DOES NOT INDICATE THE METHOD OF CONSTRUCTION. THE CONTRACTOR SHALL SUPERVISE AND DIRECT THE WORK AND HE SHALL BE SOLELY RESPONSIBLE FOR ALL CONSTRUCTION MEANS, SEQUENCES AND PROCEDURES.

Maximum Base Reactions

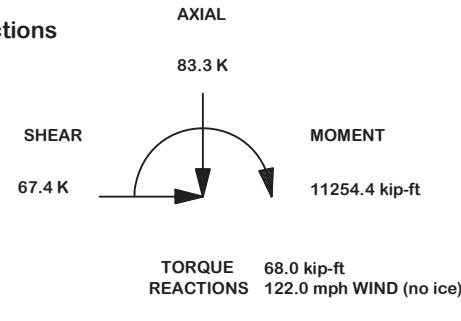

MAX. LEG REACTIONS:
 DOWN: 399.1 K
 UPLIFT: -330.9 K
 SHEAR: 43.5 K

*Factored Reactions provided per ANSI/TIA-222 Design Criteria & Load Combinations

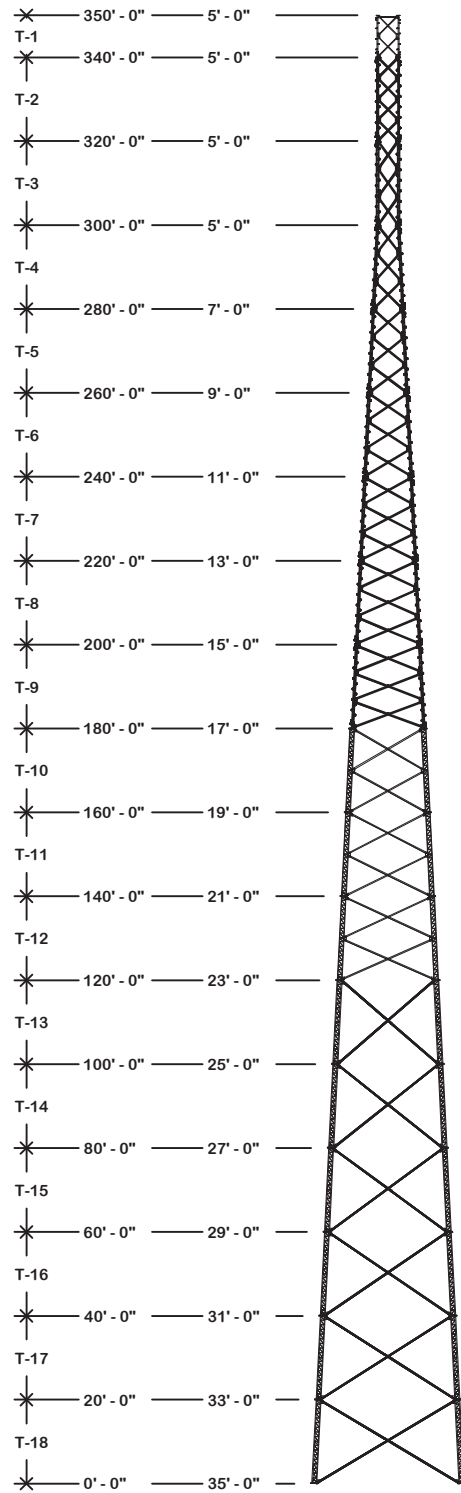

TOWER COLUMN										
SECTION	ELEVATION	FACE WIDTH	PANELS	LEG SIZE	LEG STYLE	LEG BOLT QTY & DIA	DIAGONAL BRACING SIZE	HORIZONTAL BRACING SIZE	BRACING BOLT QTY & DIA	SECTION WEIGHT
T1	340' - 350'	5.0'	2	2.50"	V	4 x 3/4"	1/8" x 2" x 2"	1/4" x 3" x 3"	1 x 3/4"	577.35
T2	320' - 340'	5.0'	4	2.50"	V	4 x 3/4"	1/8" x 2" x 2"		1 x 3/4"	948.78
T3	300' - 320'	5.0'	3	4.00"	V	6 x 3/4"	1/8" x 2" x 2"		1 x 3/4"	1241.73
T4	280' - 300'	7.0'	3	5.00"	V	8 x 3/4"	1/8" x 2" x 2"		1 x 3/4"	1526.40
T5	260' - 280'	9.0'	3	5.00"	V	8 x 3/4"	3/16" x 2" x 2"		1 x 3/4"	1729.44
T6	240' - 260'	11.0'	3	5.00"	V	8 x 3/4"	3/16" x 2" x 2"		1 x 3/4"	1804.26
T7	220' - 240'	13.0'	3	5.00"	V	8 x 3/4"	3/16" x 2-1/2" x 2-1/2"		1 x 3/4"	2040.48
T8	200' - 220'	15.0'	3	5.00"	V	8 x 3/4"	3/16" x 2-1/2" x 2-1/2"		1 x 3/4"	2146.20
T9	180' - 200'	17.0'	3	6.00"	V	6 x 1"	3/16" x 3" x 3"		1 x 3/4"	2883.75
T10	160' - 180'	19.0'	2	1.50"	12BDFH	6 x 1"	1/4" x 3-1/2" x 3-1/2"		1 x 1"	3266.97
T11	140' - 160'	21.0'	2	1.75"	12BDFH	6 x 1 1/4"	5/16" x 3-1/2" x 3-1/2"		1 x 1"	4191.87
T12	120' - 140'	23.0'	2	1.75"	12BDFH	6 x 1 1/4"	1/4" x 4" x 4"		1 x 1"	4228.83
T13	100' - 120'	25.0'	1	2.00"	12BDH2	12 x 1"	1/4" x 3-1/2" x 3-1/2"		1 x 7/8"	5007.84
T14	80' - 100'	27.0'	1	2.00"	12BDH2	12 x 1"	1/4" x 3-1/2" x 3-1/2"		1 x 7/8"	5180.49
T15	60' - 80'	29.0'	1	2.25"	12BDH2	12 x 1"	1/4" x 3-1/2" x 3-1/2"		1 x 7/8"	5817.39
T16	40' - 60'	31.0'	1	2.25"	12BDH2	12 x 1"	1/4" x 3-1/2" x 3-1/2"		1 x 7/8"	5937.12
T17	20' - 40'	33.0'	1	2.50"	12BDH2	12 x 1 1/4"	1/4" x 3-1/2" x 3-1/2"		1 x 7/8"	6820.50
T18	0' - 20'	35.0'	1	2.50"	12BDH2	12 x 1 1/4"	1/4" x 4" x 4"		1 x 7/8"	7307.88



June 1, 2020

<p>REV DESCRIPTION OF REVISIONS CPD BY DATE</p> <p>REVISION HISTORY</p>		<p>SITE</p> <p>CHATHAM LANDFILL, NC MOTOROLA SOLUTIONS U 35 X 350'</p> <p>COPYRIGHT 2013</p> <p>PROPRIETARY NOTE: THE DATA AND TECHNIQUES CONTAINED IN THIS DRAWING ARE PROPRIETARY INFORMATION OF VALMONT INDUSTRIES AND CONSIDERED A TRADE SECRET. ANY USE OR DISCLOSURE WITHOUT THE CONSENT OF VALMONT INDUSTRIES IS STRICTLY PROHIBITED.</p>	<p>DESCRIPTION</p> <p>Tower View Page 1</p>	<p>STRUCTURE APPROVAL</p> <p>MVC 5/28/2020</p>	<p>FOUNDATION APPROVAL</p>	<p>valmont STRUCTURES</p> <p>1-877-467-4763 Plymouth, IN 1-800-547-2151 Salem, OR</p>	<p>ENG. FILE NO.</p> <p>474445</p>	<p>DWG. NO.</p> <p>289290T</p>	<p>PAGE</p> <p>1 OF 20</p>
---	--	---	---	--	----------------------------	--	------------------------------------	--------------------------------	----------------------------

DESIGNED APPURTENANCE LOADING	
TYPE	ELEVATION
(1) 20' ADJUSTABLE BEACON EXTENDER	350.0000'
(1) 21' LRE WITH 7'-6" LIGHTNING ROD (ARM=11.5')	350.0000'
(1) 6' PIVOT SIDE ARM (50" PIPE)	350.0000'
(1) BEACON	350.0000'
(1) CC807-11	350.0000'
(1) TTA (12"X12"X8")	345.0000'
(2) 6' PIVOT SIDE ARM (50" PIPE)	330.0000'
(2) CC807-11	330.0000'
(2) 2-1/2" X 6' SCH. 40	295.0000'
(1) PAD6-59BC W/ RADOME (0 DEG AZIMUTH)	295.0000'
(1) 6' PIVOT SIDE ARM (50" PIPE)	270.0000'
(1) COL53-160	270.0000'
(2) 2-1/2" X 9' SCH. 40	265.0000'
(1) 6' PIVOT SIDE ARM (50" PIPE)	265.0000'
(1) CC807-11	265.0000'
(1) PAD6-59BC W/ RADOME (0 DEG AZIMUTH)	265.0000'
(1) 6' PIVOT SIDE ARM (50" PIPE)	260.0000'
(1) COL53-160	260.0000'
(12) 2" X 96" SCH. 40	200.0000'
(2) BEACON	200.0000'
(12) PANEL (8' X 1' X 4")	200.0000'
(3) SP1 VFA12-SD-S	200.0000'
(2) 2-1/2" X 17' SCH. 40	185.0000'
(1) PAD6-59BC W/ RADOME (0 DEG AZIMUTH)	185.0000'
(2) 2-1/2" X 19' SCH. 40	165.0000'
(1) PAD6-59BC W/ RADOME (0 DEG AZIMUTH)	165.0000'



June 1, 2020

				SITE CHATHAM LANDFILL, NC MOTOROLA SOLUTIONS U 35 X 350'		DESCRIPTION Tower View Page 2		 1-877-467-4763 Plymouth, IN 1-800-547-2151 Salem, OR		PAGE 2 OF 20
				COPYRIGHT 2013				ENG. FILE NO. 474445		
REV	DESCRIPTION OF REVISIONS	CPD	BY	DATE	PROPRIETARY NOTE: THE DATA AND TECHNIQUES CONTAINED IN THIS DRAWING ARE PROPRIETARY INFORMATION OF VALMONT INDUSTRIES AND CONSIDERED A TRADE SECRET. ANY USE OR DISCLOSURE WITHOUT THE CONSENT OF VALMONT INDUSTRIES IS STRICTLY PROHIBITED.		STRUCTURE APPROVAL MVC 5/28/2020		FOUNDATION APPROVAL	
REVISION HISTORY							DWG. NO. 289290T			

ORIENT LEGS WITH P/N STAMP
TOWARD BOTTOM OF SECTION

ORIENT ANGLES WITH STAMPED END TOWARD TOP OF SECTION
** DIAGONAL ANGLES MUST BE INSTALLED WITH THE NON-BOLTED FACE UP, 

* STITCH BOLT SPACING SHOWN
IS MAX. FOR ALL ANGLES

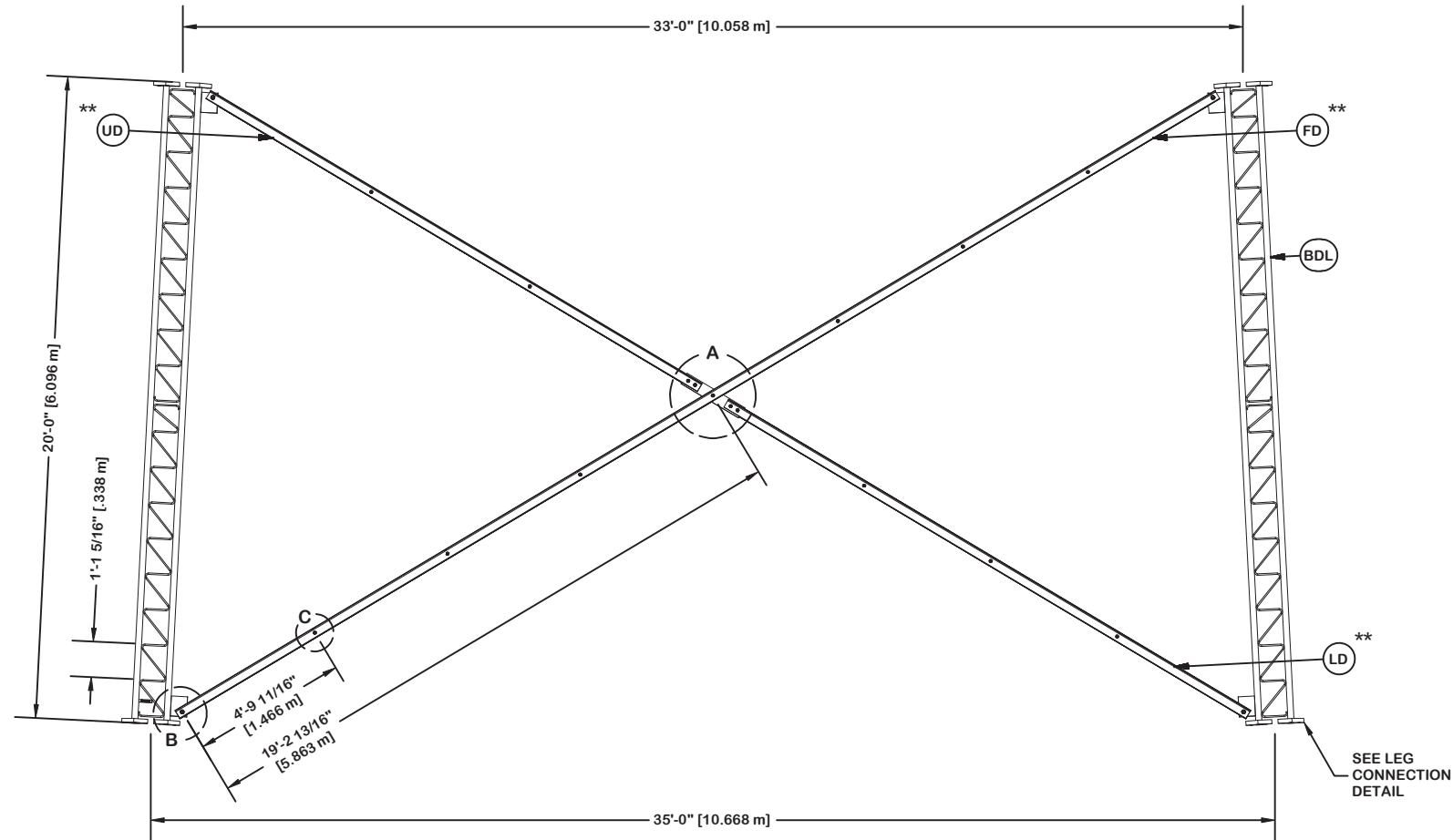

PARTS LIST					
ITEM	QTY	PART NO.	PART DESCRIPTION	UNIT WT.	NET WT.
BDL	3	195964	#12 LEG SECTION - 2-1/2" LEG - 1/2" BRACE - 7/8" B	1373.720	4121.160
UD	6	265853	U-35 UPPER ANGLE - SINGLE BOLT FOR 20'-0" LONG TA	122.850	737.100
LD	6	265852	U-35 LOWER ANGLE - SINGLE BOLT FOR 20'-0" LONG TA	130.580	783.480
FD	6	265851	U-35 LONG ANGLE - SINGLE BOLT FOR 20'-0" LONG TAP	260.650	1563.900
ML	33	312123	5/8" GALVANIZED LOCKWASHER (53-22230)	0.020	0.660
MN	33	312501	5/8"-11 HOT DIPPED GALVANIZED NUT	0.120	3.960
AS	33	104291	RING FILL SPACER 1/2" THICK 1.049" HOLE	0.070	2.310
MB	33	161895	5/8"-11 X 2 1/4" A-325 BOLT 1 1/4" THREAD	0.260	8.580
AB/CB	15	161895	5/8"-11 X 2 1/4" A-325 BOLT 1 1/4" THREAD	0.260	3.900
AL / CL	15	312123	5/8" GALVANIZED LOCKWASHER (53-22230)	0.020	0.300
AN / CN	15	312501	5/8"-11 HOT DIPPED GALVANIZED NUT	0.120	1.800
DCP	3	211833	MID BRACE CONNECTION PLATE FOR #12 B/D LEG ANGLES	20.590	61.770
SL	12	312193	7/8" GALVANIZED LOCKWASHER	0.050	0.600
SN	12	312215	7/8"-9 HOT DIPPED GALVANIZED NUT	0.300	3.600
SB	12	172275	7/8"-9 X 2-1/2" A-325 BOLT WITH 1-1/2" THREAD	1.230	14.760
Total Wt				7307.88 lb [3317.84 kg]	

NOTE: THE VIEWS SHOWN BELOW ARE FOR PART IDENTIFICATION ONLY. THE ACTUAL PART STYLE MAY VARY FROM WHAT IS DEPICTED BELOW.
PLEASE SEE ASSEMBLY INFORMATION IN THE UPPER LEFT CORNER FOR FURTHER INSTALLATION INSTRUCTIONS.

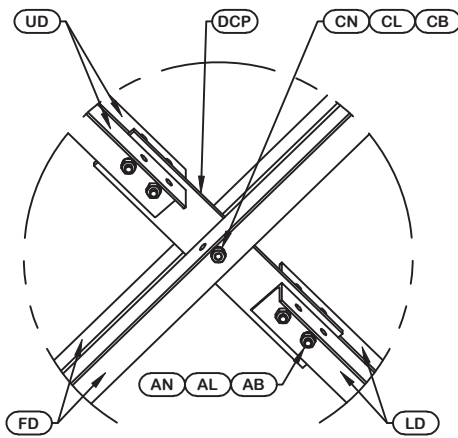

DETAIL A
ANGLE INTERSECTION CONNECTION

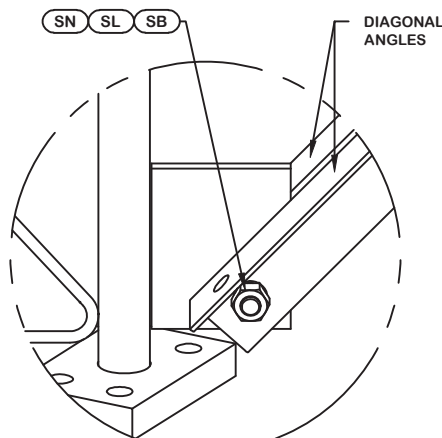

DETAIL B
END SIDE PLATE ANGLE CONNECTION

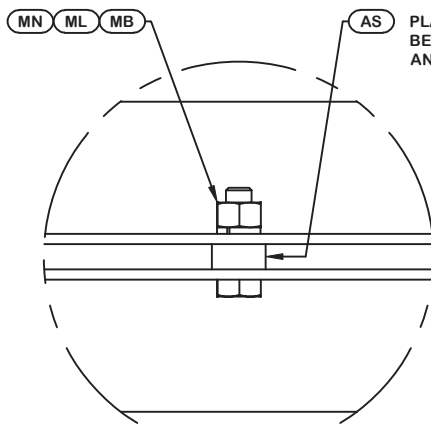

DETAIL C
STITCH BOLT CONNECTION

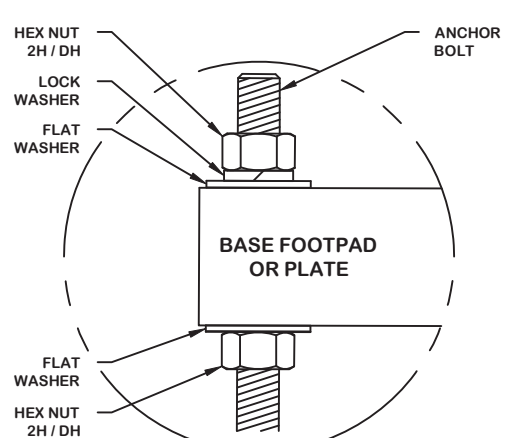

ANCHOR BOLT ASSY. (TYP)
SEE FOUNDATION DRAWING FOR DETAILS



June 1, 2020

REV	DESCRIPTION OF REVISIONS	CPD	BY	DATE
REVISION HISTORY				

SITE	CHATHAM LANDFILL, NC MOTOROLA SOLUTIONS U 35 X 350'
COPYRIGHT 2013	
<small>PROPRIETARY NOTE: THE DATA AND TECHNIQUES CONTAINED IN THIS DRAWING ARE PROPRIETARY INFORMATION OF VALMONT INDUSTRIES AND CONSIDERED A TRADE SECRET. ANY USE OR DISCLOSURE WITHOUT THE CONSENT OF VALMONT INDUSTRIES IS STRICTLY PROHIBITED.</small>	

DESCRIPTION	SECTION U-35.0 (0' - 20' ELEVATION)
STRUCTURE APPROVAL	MVC 5/28/2020
FOUNDATION APPROVAL	

valmont 	
1-877-467-4763 Plymouth, IN 1-800-547-2151 Salem, OR	
ENG. FILE NO.	474445
DWG. NO.	289290T
PAGE 3 OF 20	

ORIENT LEGS WITH P/N STAMP
TOWARD BOTTOM OF SECTION

ORIENT ANGLES WITH STAMPED END TOWARD TOP OF SECTION
** DIAGONAL ANGLES MUST BE INSTALLED WITH THE NON-BOLTED FACE UP, 

* STITCH BOLT SPACING SHOWN
IS MAX. FOR ALL ANGLES

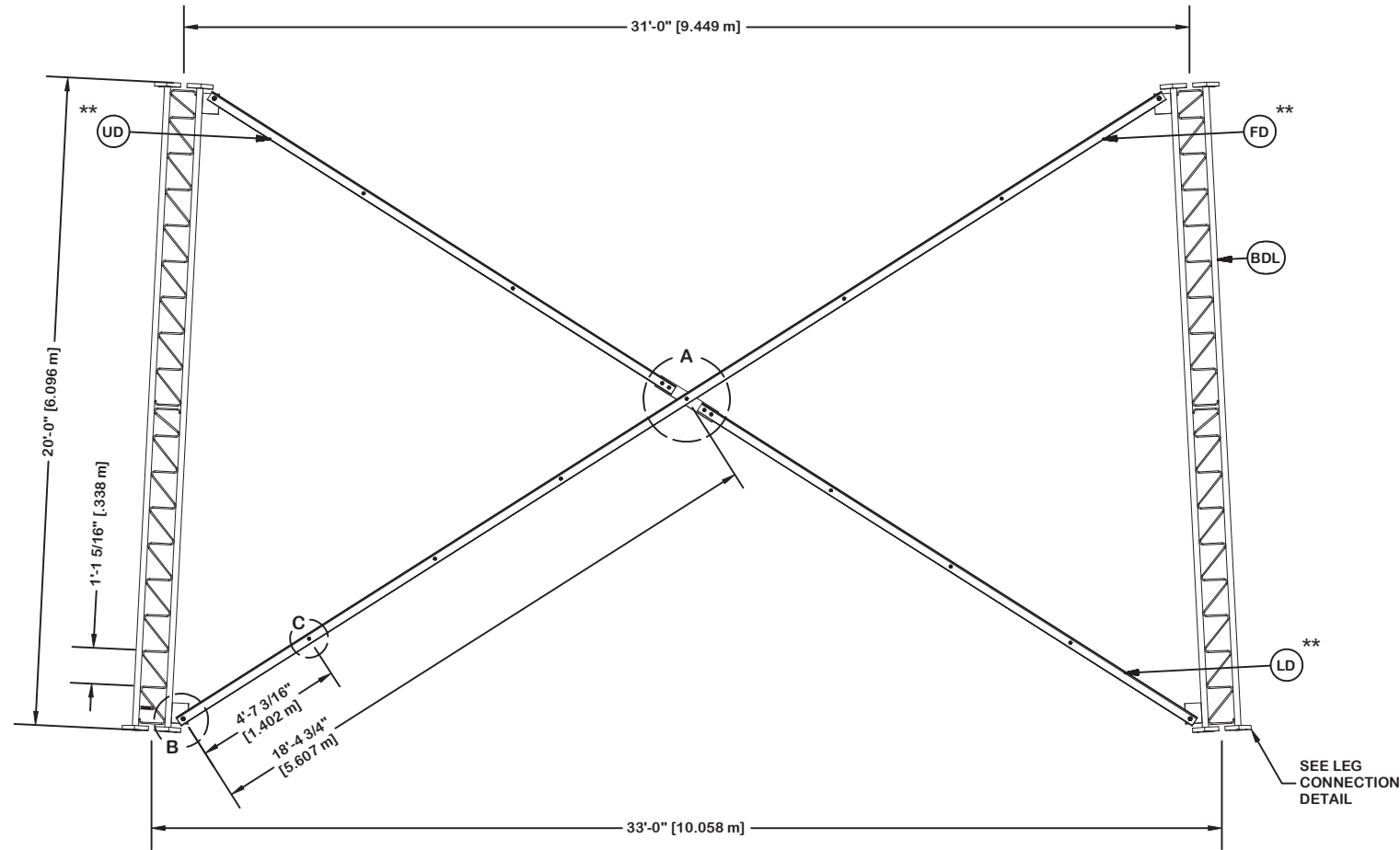

PARTS LIST					
ITEM	QTY	PART NO.	PART DESCRIPTION	UNIT WT.	NET WT.
BDL	3	195962	#12 LEG SECT - 2-1/2" TO 2" TRANS LEG - 1/2" BRACE	1335.350	4006.050
UD	6	265841	U-33 UPPER ANGLE - SINGLE BOLT FOR 20'-0" LONG TA	102.710	616.260
LD	6	265840	U-33 LOWER ANGLE - SINGLE BOLT FOR 20'-0" LONG TA	109.630	657.780
FD	6	265839	U-33 LONG ANGLE - SINGLE BOLT FOR 20'-0" LONG TAP	218.690	1312.140
ML	30	312123	5/8" GALVANIZED LOCKWASHER (53-22230)	0.020	0.600
MN	30	312501	5/8"-11 HOT DIPPED GALVANIZED NUT	0.120	3.600
AS	30	104291	RING FILL SPACER 1/2" THICK 1.049" HOLE	0.070	2.100
MB	30	161895	5/8"-11 X 2 1/4" A-325 BOLT 1 1/4" THREAD	0.260	7.800
AB/CB	15	161895	5/8"-11 X 2 1/4" A-325 BOLT 1 1/4" THREAD	0.260	3.900
AL / CL	15	312123	5/8" GALVANIZED LOCKWASHER (53-22230)	0.020	0.300
AN / CN	15	312501	5/8"-11 HOT DIPPED GALVANIZED NUT	0.120	1.800
DCP	3	211833	MID BRACE CONNECTION PLATE FOR #12 B/D LEG ANGLES	20.590	61.770
SL	12	312193	7/8" GALVANIZED LOCKWASHER	0.050	0.600
SN	12	312215	7/8"-9 HOT DIPPED GALVANIZED NUT	0.300	3.600
SB	12	172275	7/8"-9 X 2-1/2" A-325 BOLT WITH 1-1/2" THREAD	1.230	14.760
LCB	36	222022	1-1/4"-7 X 5-1/2" A-325 BOLT WITH 2" THREAD	2.530	91.080
LCF	36	312282	1-1/4" GALVANIZED FLAT WASHER (F436)	0.130	4.680
LCL	36	312283	1-1/4" GALVANIZED LOCKWASHER	0.150	5.400
LCN	36	312507	1-1/4"-7 HOT DIPPED GALVANIZED NUT	0.730	26.280
Total Wt				6820.50 lb [3096.57 kg]	

NOTE: THE VIEWS SHOWN BELOW ARE FOR PART IDENTIFICATION ONLY. THE ACTUAL PART STYLE MAY VARY FROM WHAT IS DEPICTED BELOW.
PLEASE SEE ASSEMBLY INFORMATION IN THE UPPER LEFT CORNER FOR FURTHER INSTALLATION INSTRUCTIONS.

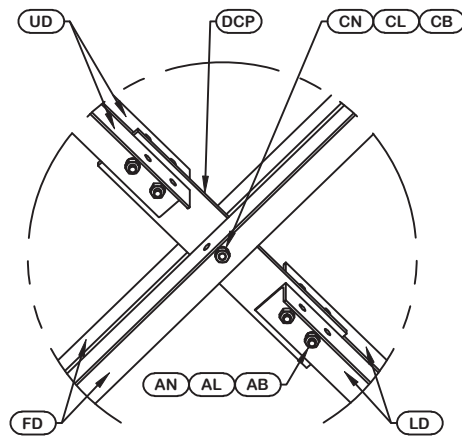

DETAIL A
ANGLE INTERSECTION CONNECTION

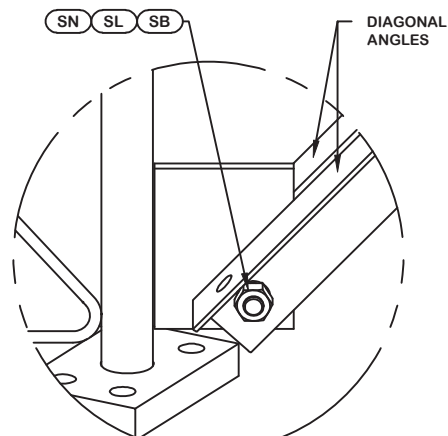

DETAIL B
END SIDE PLATE ANGLE CONNECTION

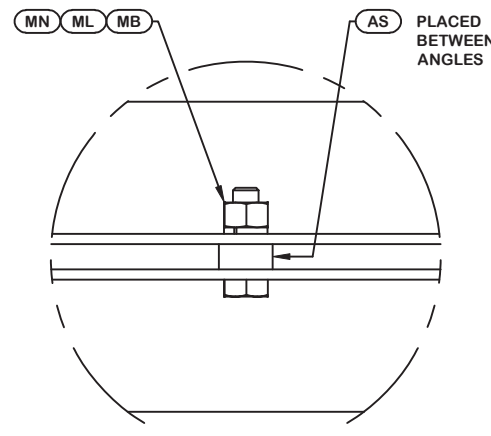

DETAIL C
STITCH BOLT CONNECTION

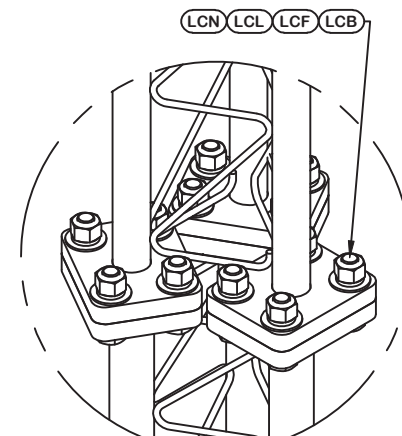

LEG TO LEG CONNECTION
(SIDE PLATES NOT SHOWN FOR CLARITY)



June 1, 2020

REV	DESCRIPTION OF REVISIONS	CPD	BY	DATE
REVISION HISTORY				

SITE	CHATHAM LANDFILL, NC MOTOROLA SOLUTIONS U 35 X 350'
COPYRIGHT 2013	
PROPRIETARY NOTE:	THE DATA AND TECHNIQUES CONTAINED IN THIS DRAWING ARE PROPRIETARY INFORMATION OF VALMONT INDUSTRIES AND CONSIDERED A TRADE SECRET. ANY USE OR DISCLOSURE WITHOUT THE CONSENT OF VALMONT INDUSTRIES IS STRICTLY PROHIBITED.

DESCRIPTION	SECTION U-33.0 (20' - 40' ELEVATION)
STRUCTURE APPROVAL	MVC 5/28/2020
FOUNDATION APPROVAL	

valmont 	
1-877-467-4763 Plymouth, IN 1-800-547-2151 Salem, OR	
ENG. FILE NO.	474445
DWG. NO.	289290T
PAGE 4 OF 20	

ORIENT LEGS WITH P/N STAMP
TOWARD BOTTOM OF SECTION

ORIENT ANGLES WITH STAMPED END TOWARD TOP OF SECTION
** DIAGONAL ANGLES MUST BE INSTALLED WITH THE NON-BOLTED FACE UP, **T** ↑

* STITCH BOLT SPACING SHOWN
IS MAX. FOR ALL ANGLES

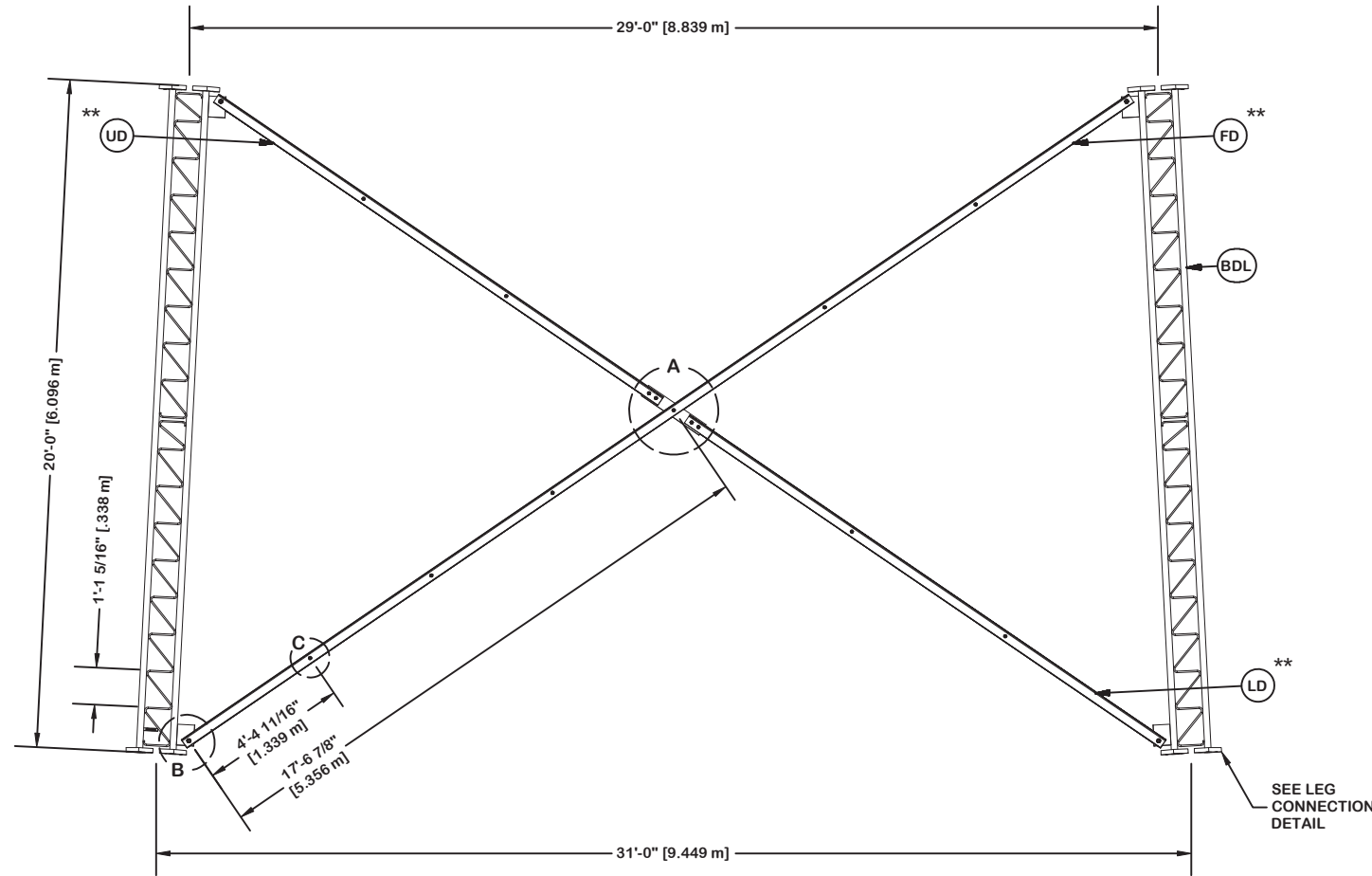

PARTS LIST					
ITEM	QTY	PART NO.	PART DESCRIPTION	UNIT WT.	NET WT.
BDL	3	195960	#12 LEG SECTION - 2-1/4" LEG - 1/2" BRACE - 7/8" B	1100.520	3301.560
UD	6	265817	U-31 UPPER ANGLE - SINGLE BOLT FOR 20'-0" LONG TA	97.370	584.220
LD	6	265816	U-31 LOWER ANGLE - SINGLE BOLT FOR 20'-0" LONG TA	104.620	627.720
FD	6	265815	U-31 LONG ANGLE - SINGLE BOLT FOR 20'-0" LONG TAP	208.520	1251.120
ML	27	312123	5/8" GALVANIZED LOCKWASHER (53-22230)	0.020	0.540
MN	27	312501	5/8"-11 HOT DIPPED GALVANIZED NUT	0.120	3.240
AS	27	104291	RING FILL SPACER 1/2" THICK 1.049" HOLE	0.070	1.890
MB	27	161895	5/8"-11 X 2 1/4" A-325 BOLT 1 1/4" THREAD	0.260	7.020
AB/CB	15	161895	5/8"-11 X 2 1/4" A-325 BOLT 1 1/4" THREAD	0.260	3.900
AL / CL	15	312123	5/8" GALVANIZED LOCKWASHER (53-22230)	0.020	0.300
AN / CN	15	312501	5/8"-11 HOT DIPPED GALVANIZED NUT	0.120	1.800
DCP	3	211833	MID BRACE CONNECTION PLATE FOR #12 B/D LEG ANGLES	20.590	61.770
SL	12	312193	7/8" GALVANIZED LOCKWASHER	0.050	0.600
SN	12	312215	7/8"-9 HOT DIPPED GALVANIZED NUT	0.300	3.600
SB	12	172275	7/8"-9 X 2-1/2" A-325 BOLT WITH 1-1/2" THREAD	1.230	14.760
LCB	36	222016	1"-8 X 4-3/4" A-325 BOLT WITH 1-3/4" THREAD	1.380	49.680
LCF	36	312222	1" GALVANIZED FLAT WASHER (F436)	0.140	5.040
LCL	36	312223	1" GALVANIZED LOCKWASHER	0.080	2.880
LCN	36	312504	1"-8 HOT DIPPED GALVANIZED NUT	0.430	15.480
Total Wt				5937.12 lb [2695.51 kg]	

NOTE: THE VIEWS SHOWN BELOW ARE FOR PART IDENTIFICATION ONLY. THE ACTUAL PART STYLE MAY VARY FROM WHAT IS DEPICTED BELOW.
PLEASE SEE ASSEMBLY INFORMATION IN THE UPPER LEFT CORNER FOR FURTHER INSTALLATION INSTRUCTIONS.

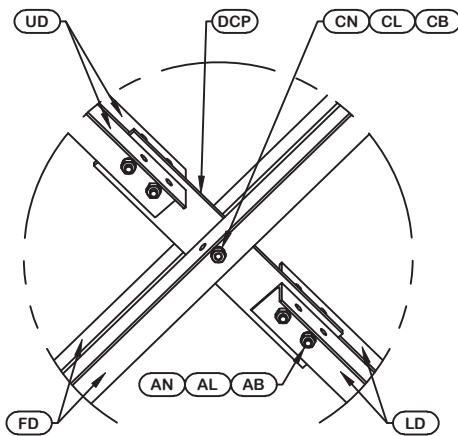

DETAIL A
ANGLE INTERSECTION CONNECTION

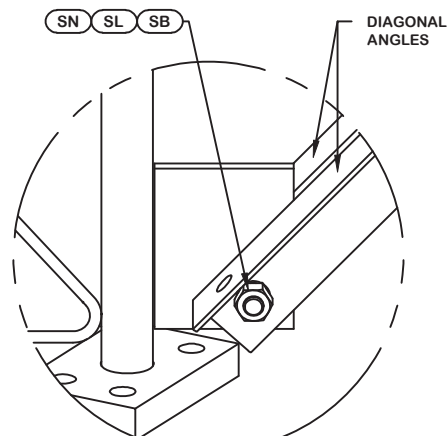

DETAIL B
END SIDE PLATE ANGLE CONNECTION

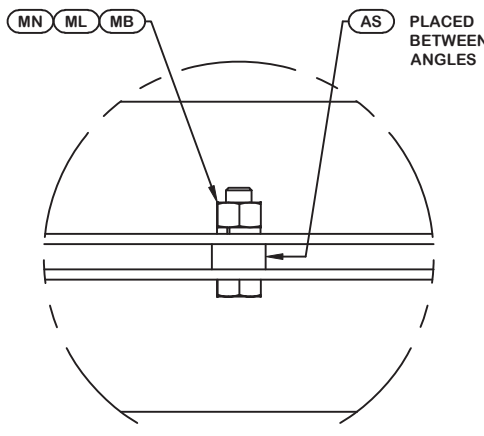

DETAIL C
STITCH BOLT CONNECTION

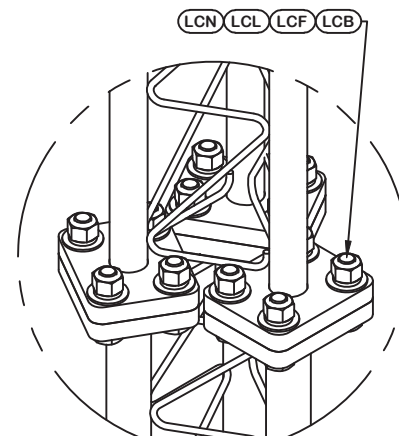

LEG TO LEG CONNECTION
(SIDE PLATES NOT SHOWN FOR CLARITY)



June 1, 2020

REV	DESCRIPTION OF REVISIONS	CPD	BY	DATE
REVISION HISTORY				

SITE	CHATHAM LANDFILL, NC MOTOROLA SOLUTIONS U 35 X 350'
COPYRIGHT 2013	
PROPRIETARY NOTE:	THE DATA AND TECHNIQUES CONTAINED IN THIS DRAWING ARE PROPRIETARY INFORMATION OF VALMONT INDUSTRIES AND CONSIDERED A TRADE SECRET. ANY USE OR DISCLOSURE WITHOUT THE CONSENT OF VALMONT INDUSTRIES IS STRICTLY PROHIBITED.

DESCRIPTION	SECTION U-31.0 (40' - 60' ELEVATION)
STRUCTURE APPROVAL	MVC 5/28/2020
FOUNDATION APPROVAL	

valmont	
1-877-467-4763 Plymouth, IN 1-800-547-2151 Salem, OR	
ENG. FILE NO.	474445
DWG. NO.	289290T
PAGE 5 OF 20	

ORIENT LEGS WITH P/N STAMP
TOWARD BOTTOM OF SECTION

ORIENT ANGLES WITH STAMPED END TOWARD TOP OF SECTION
** DIAGONAL ANGLES MUST BE INSTALLED WITH THE NON-BOLTED FACE UP, 

* STITCH BOLT SPACING SHOWN
IS MAX. FOR ALL ANGLES

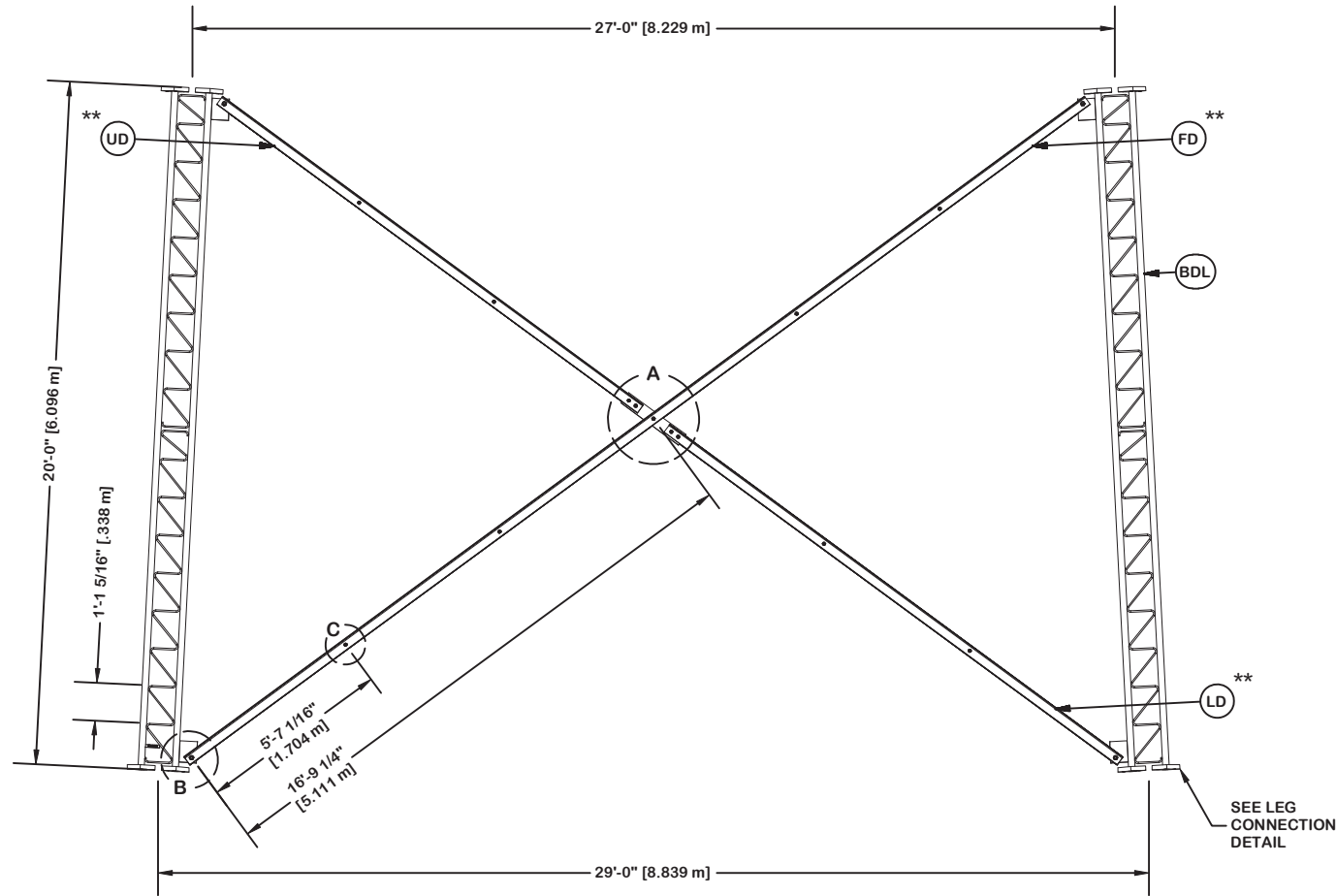

PARTS LIST					
ITEM	QTY	PART NO.	PART DESCRIPTION	UNIT WT.	NET WT.
BDL	3	195960	#12 LEG SECTION - 2-1/4" LEG - 1/2" BRACE - 7/8" B	1100.520	3301.560
UD	6	265799	U-29 UPPER ANGLE - SINGLE BOLT FOR 20'-0" LONG TA	92.490	554.940
LD	6	265798	U-29 LOWER ANGLE - SINGLE BOLT FOR 20'-0" LONG TA	99.730	598.380
FD	6	265797	U-29 LONG ANGLE - SINGLE BOLT FOR 20'-0" LONG TAP	198.570	1191.420
ML	24	312123	5/8" GALVANIZED LOCKWASHER (53-22230)	0.020	0.480
MN	24	312501	5/8"-11 HOT DIPPED GALVANIZED NUT	0.120	2.880
AS	24	104291	RING FILL SPACER 1/2" THICK 1.049" HOLE	0.070	1.680
MB	24	161895	5/8"-11 X 2 1/4" A-325 BOLT 1 1/4" THREAD	0.260	6.240
AB/CB	15	161895	5/8"-11 X 2 1/4" A-325 BOLT 1 1/4" THREAD	0.260	3.900
AL / CL	15	312123	5/8" GALVANIZED LOCKWASHER (53-22230)	0.020	0.300
AN / CN	15	312501	5/8"-11 HOT DIPPED GALVANIZED NUT	0.120	1.800
DCP	3	211833	MID BRACE CONNECTION PLATE FOR #12 B/D LEG ANGLES	20.590	61.770
SL	12	312193	7/8" GALVANIZED LOCKWASHER	0.050	0.600
SN	12	312215	7/8"-9 HOT DIPPED GALVANIZED NUT	0.300	3.600
SB	12	172275	7/8"-9 X 2-1/2" A-325 BOLT WITH 1-1/2" THREAD	1.230	14.760
LCB	36	222016	1"-8 X 4-3/4" A-325 BOLT WITH 1-3/4" THREAD	1.380	49.680
LCF	36	312222	1" GALVANIZED FLAT WASHER (F436)	0.140	5.040
LCL	36	312223	1" GALVANIZED LOCKWASHER	0.080	2.880
LCN	36	312504	1"-8 HOT DIPPED GALVANIZED NUT	0.430	15.480
Total Wt				5817.39 lb	[2641.15 kg]

NOTE: THE VIEWS SHOWN BELOW ARE FOR PART IDENTIFICATION ONLY. THE ACTUAL PART STYLE MAY VARY FROM WHAT IS DEPICTED BELOW.
PLEASE SEE ASSEMBLY INFORMATION IN THE UPPER LEFT CORNER FOR FURTHER INSTALLATION INSTRUCTIONS.

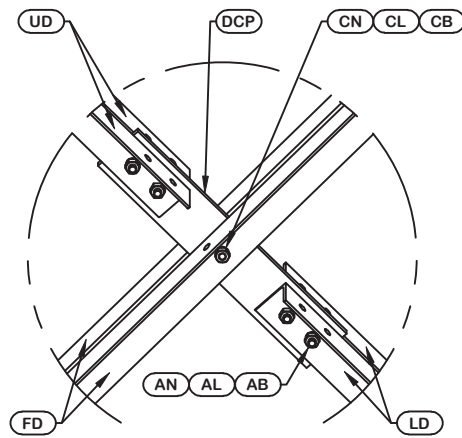

DETAIL A
ANGLE INTERSECTION CONNECTION

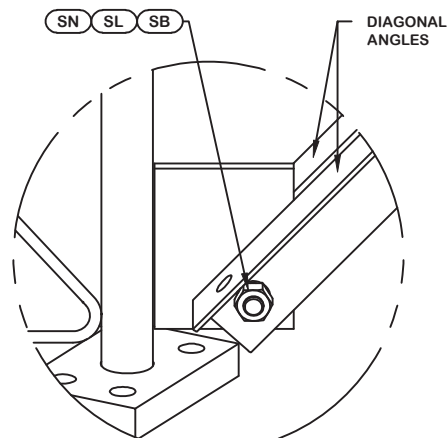

DETAIL B
END SIDE PLATE ANGLE CONNECTION

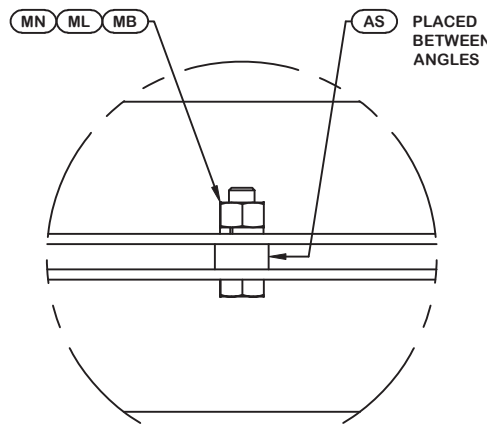

DETAIL C
STITCH BOLT CONNECTION

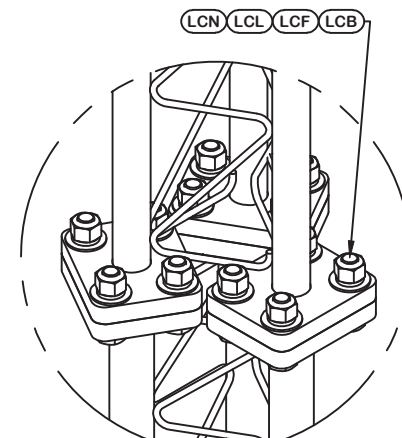

LEG TO LEG CONNECTION
(SIDE PLATES NOT SHOWN FOR CLARITY)



June 1, 2020

REV	DESCRIPTION OF REVISIONS	CPD	BY	DATE
REVISION HISTORY				

SITE	CHATHAM LANDFILL, NC MOTOROLA SOLUTIONS U 35 X 350'
COPYRIGHT 2013	
PROPRIETARY NOTE:	THE DATA AND TECHNIQUES CONTAINED IN THIS DRAWING ARE PROPRIETARY INFORMATION OF VALMONT INDUSTRIES AND CONSIDERED A TRADE SECRET. ANY USE OR DISCLOSURE WITHOUT THE CONSENT OF VALMONT INDUSTRIES IS STRICTLY PROHIBITED.

DESCRIPTION	SECTION U-29.0 (60' - 80' ELEVATION)
STRUCTURE APPROVAL	MVC 5/28/2020
FOUNDATION APPROVAL	

valmont 	
1-877-467-4763 Plymouth, IN 1-800-547-2151 Salem, OR	
ENG. FILE NO.	474445
DWG. NO.	289290T

ORIENT LEGS WITH P/N STAMP
TOWARD BOTTOM OF SECTION

ORIENT ANGLES WITH STAMPED END TOWARD TOP OF SECTION
** DIAGONAL ANGLES MUST BE INSTALLED WITH THE NON-BOLTED FACE UP, 

* STITCH BOLT SPACING SHOWN
IS MAX. FOR ALL ANGLES

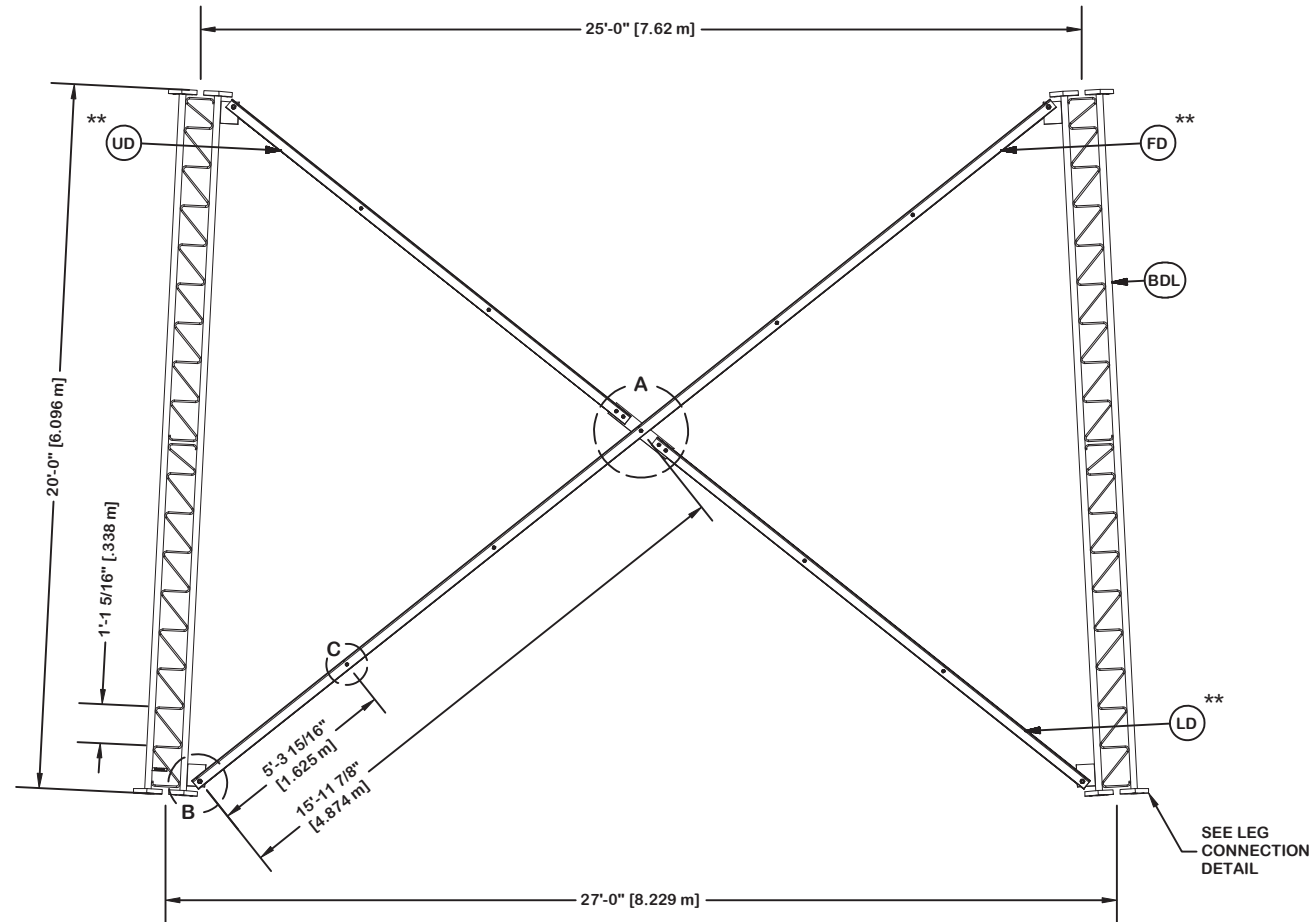

PARTS LIST					
ITEM	QTY	PART NO.	PART DESCRIPTION	UNIT WT.	NET WT.
BDL	3	195639	#12 LEG SECTION - 2" LEG - 1/2" BRACE - 7/8" BOLT	926.920	2780.760
UD	6	265778	U-27 UPPER ANGLE - SINGLE BOLT FOR 20'-0" LONG TA	87.550	525.300
LD	6	265777	U-27 LOWER ANGLE - SINGLE BOLT FOR 20'-0" LONG TA	95.000	570.000
FD	6	265776	U-27 LONG ANGLE - SINGLE BOLT FOR 20'-0" LONG TAP	188.890	1133.340
ML	24	312123	5/8" GALVANIZED LOCKWASHER (53-22230)	0.020	0.480
MN	24	312501	5/8"-11 HOT DIPPED GALVANIZED NUT	0.120	2.880
AS	24	104291	RING FILL SPACER 1/2" THICK 1.049" HOLE	0.070	1.680
MB	24	161895	5/8"-11 X 2 1/4" A-325 BOLT 1 1/4" THREAD	0.260	6.240
AB/CB	15	161895	5/8"-11 X 2 1/4" A-325 BOLT 1 1/4" THREAD	0.260	3.900
AL / CL	15	312123	5/8" GALVANIZED LOCKWASHER (53-22230)	0.020	0.300
AN / CN	15	312501	5/8"-11 HOT DIPPED GALVANIZED NUT	0.120	1.800
DCP	3	211833	MID BRACE CONNECTION PLATE FOR #12 B/D LEG ANGLES	20.590	61.770
SL	12	312193	7/8" GALVANIZED LOCKWASHER	0.050	0.600
SN	12	312215	7/8"-9 HOT DIPPED GALVANIZED NUT	0.300	3.600
SB	12	172275	7/8"-9 X 2-1/2" A-325 BOLT WITH 1-1/2" THREAD	1.230	14.760
LCB	36	222016	1"-8 X 4-3/4" A-325 BOLT WITH 1-3/4" THREAD	1.380	49.680
LCF	36	312222	1" GALVANIZED FLAT WASHER (F436)	0.140	5.040
LCL	36	312223	1" GALVANIZED LOCKWASHER	0.080	2.880
LCN	36	312504	1"-8 HOT DIPPED GALVANIZED NUT	0.430	15.480
Total Wt				5180.49 lb [2351.99 kg]	

NOTE: THE VIEWS SHOWN BELOW ARE FOR PART IDENTIFICATION ONLY. THE ACTUAL PART STYLE MAY VARY FROM WHAT IS DEPICTED BELOW. PLEASE SEE ASSEMBLY INFORMATION IN THE UPPER LEFT CORNER FOR FURTHER INSTALLATION INSTRUCTIONS.

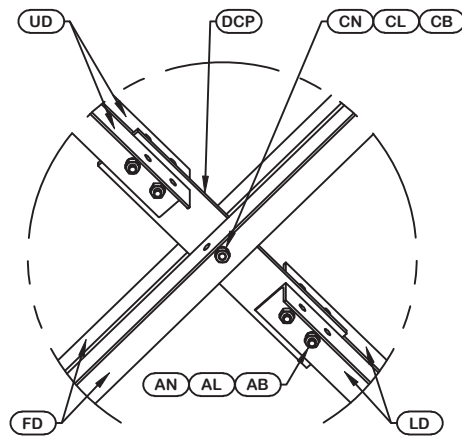

DETAIL A
ANGLE INTERSECTION CONNECTION

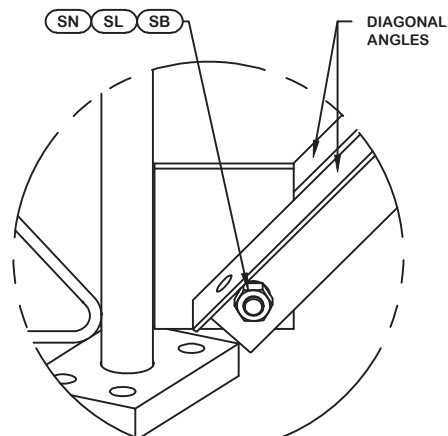

DETAIL B
END SIDE PLATE ANGLE CONNECTION

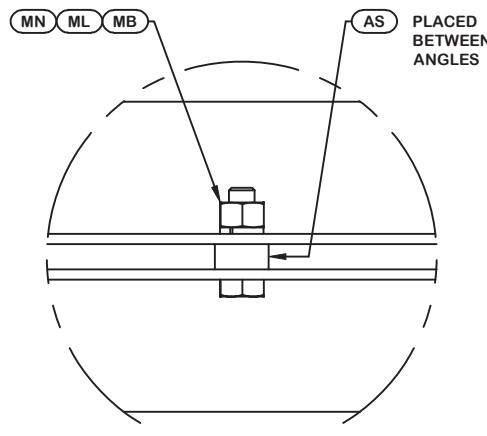

DETAIL C
STITCH BOLT CONNECTION

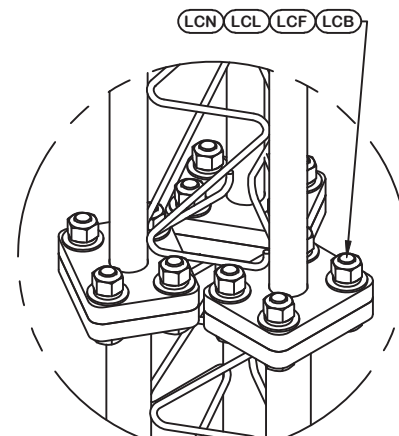

LEG TO LEG CONNECTION
(SIDE PLATES NOT SHOWN FOR CLARITY)



June 1, 2020

REV	DESCRIPTION OF REVISIONS	CPD	BY	DATE
REVISION HISTORY				

SITE	CHATHAM LANDFILL, NC MOTOROLA SOLUTIONS U 35 X 350'
COPYRIGHT 2013	
PROPRIETARY NOTE:	THE DATA AND TECHNIQUES CONTAINED IN THIS DRAWING ARE PROPRIETARY INFORMATION OF VALMONT INDUSTRIES AND CONSIDERED A TRADE SECRET. ANY USE OR DISCLOSURE WITHOUT THE CONSENT OF VALMONT INDUSTRIES IS STRICTLY PROHIBITED.

DESCRIPTION	SECTION U-27.0 (80' - 100' ELEVATION)
STRUCTURE APPROVAL	MVC 5/28/2020
FOUNDATION APPROVAL	

valmont 	
1-877-467-4763 Plymouth, IN 1-800-547-2151 Salem, OR	
STRUCTURES	
ENG. FILE NO.	474445
DWG. NO.	289290T

ORIENT LEGS WITH P/N STAMP
TOWARD BOTTOM OF SECTION

ORIENT ANGLES WITH STAMPED END TOWARD TOP OF SECTION
** DIAGONAL ANGLES MUST BE INSTALLED WITH THE NON-BOLTED FACE UP, 

* STITCH BOLT SPACING SHOWN
IS MAX. FOR ALL ANGLES

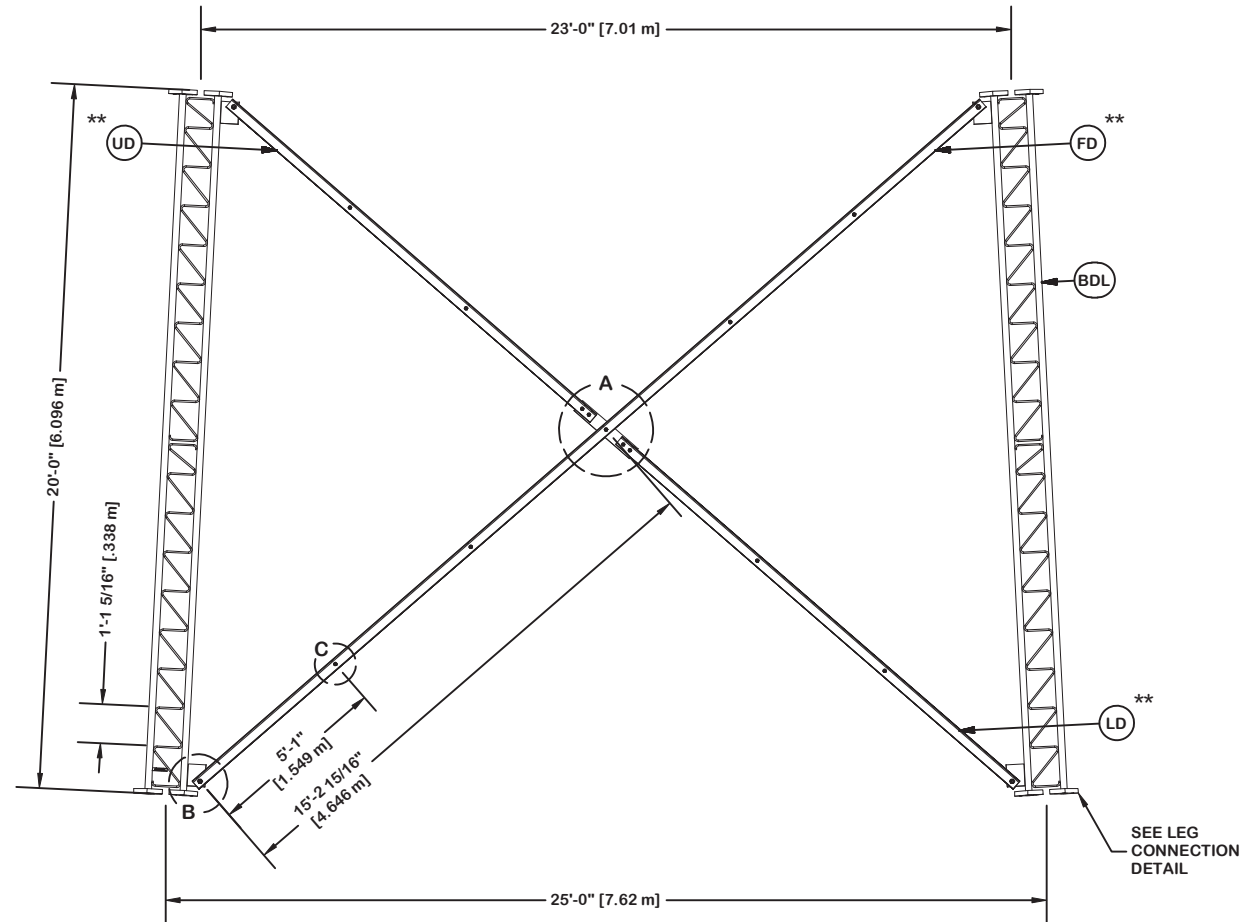

PARTS LIST					
ITEM	QTY	PART NO.	PART DESCRIPTION	UNIT WT.	NET WT.
BDL	3	195637	#12 LEG SECT - 2" TO 1-3/4" TRANS LEG - 1/2" BRACE	906.870	2720.610
UD	6	265754	U-25 UPPER ANGLE - SINGLE BOLT FOR 20'-0" LONG TA	82.720	496.320
LD	6	265753	U-25 LOWER ANGLE - SINGLE BOLT FOR 20'-0" LONG TA	90.450	542.700
FD	6	265752	U-25 LONG ANGLE - SINGLE BOLT FOR 20'-0" LONG TAP	179.520	1077.120
ML	24	312123	5/8" GALVANIZED LOCKWASHER (53-22230)	0.020	0.480
MN	24	312501	5/8"-11 HOT DIPPED GALVANIZED NUT	0.120	2.880
AS	24	104291	RING FILL SPACER 1/2" THICK 1.049" HOLE	0.070	1.680
MB	24	161895	5/8"-11 X 2 1/4" A-325 BOLT 1 1/4" THREAD	0.260	6.240
AB/CB	15	161895	5/8"-11 X 2 1/4" A-325 BOLT 1 1/4" THREAD	0.260	3.900
AL / CL	15	312123	5/8" GALVANIZED LOCKWASHER (53-22230)	0.020	0.300
AN / CN	15	312501	5/8"-11 HOT DIPPED GALVANIZED NUT	0.120	1.800
DCP	3	211833	MID BRACE CONNECTION PLATE FOR #12 B/D LEG ANGLES	20.590	61.770
SL	12	312193	7/8" GALVANIZED LOCKWASHER	0.050	0.600
SN	12	312215	7/8"-9 HOT DIPPED GALVANIZED NUT	0.300	3.600
SB	12	172275	7/8"-9 X 2-1/2" A-325 BOLT WITH 1-1/2" THREAD	1.230	14.760
LCB	36	222016	1"-8 X 4-3/4" A-325 BOLT WITH 1-3/4" THREAD	1.380	49.680
LCF	36	312222	1" GALVANIZED FLAT WASHER (F436)	0.140	5.040
LCL	36	312223	1" GALVANIZED LOCKWASHER	0.080	2.880
LCN	36	312504	1"-8 HOT DIPPED GALVANIZED NUT	0.430	15.480
Total Wt				5007.84 lb [2273.60 kg]	

NOTE: THE VIEWS SHOWN BELOW ARE FOR PART IDENTIFICATION ONLY. THE ACTUAL PART STYLE MAY VARY FROM WHAT IS DEPICTED BELOW. PLEASE SEE ASSEMBLY INFORMATION IN THE UPPER LEFT CORNER FOR FURTHER INSTALLATION INSTRUCTIONS.

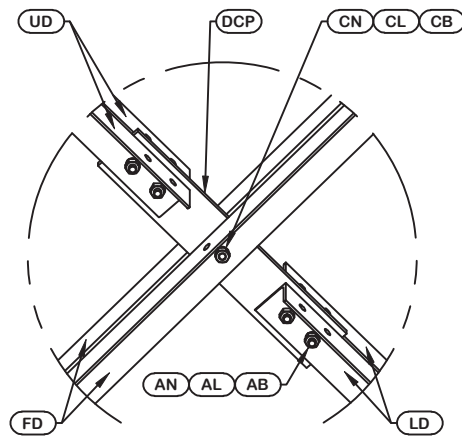

DETAIL A
ANGLE INTERSECTION CONNECTION

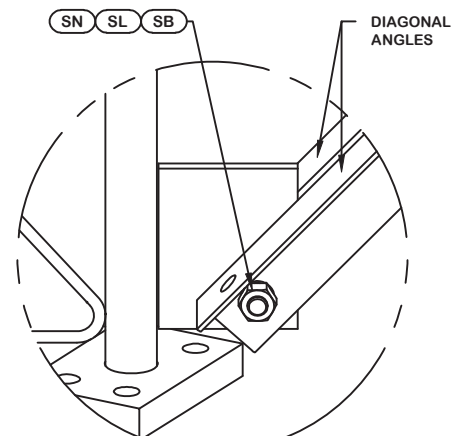

DETAIL B
END SIDE PLATE ANGLE CONNECTION

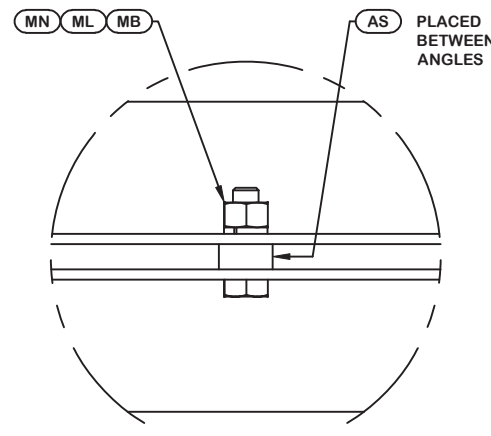

DETAIL C
STITCH BOLT CONNECTION

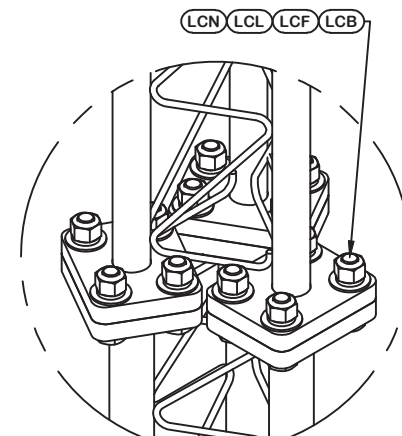

LEG TO LEG CONNECTION
(SIDE PLATES NOT SHOWN FOR CLARITY)



June 1, 2020

REV	DESCRIPTION OF REVISIONS	CPD	BY	DATE
REVISION HISTORY				

SITE	CHATHAM LANDFILL, NC MOTOROLA SOLUTIONS U 35 X 350'
COPYRIGHT 2013	
PROPRIETARY NOTE:	THE DATA AND TECHNIQUES CONTAINED IN THIS DRAWING ARE PROPRIETARY INFORMATION OF VALMONT INDUSTRIES AND CONSIDERED A TRADE SECRET. ANY USE OR DISCLOSURE WITHOUT THE CONSENT OF VALMONT INDUSTRIES IS STRICTLY PROHIBITED.

DESCRIPTION	SECTION U-25.0 (100' - 120' ELEVATION)
STRUCTURE APPROVAL	MVC 5/28/2020
FOUNDATION APPROVAL	

valmont 	
1-877-467-4763 Plymouth, IN 1-800-547-2151 Salem, OR	
STRUCTURES	
ENG. FILE NO.	474445
DWG. NO.	289290T

ORIENT LEGS WITH P/N STAMP
TOWARD BOTTOM OF SECTION

ORIENT ANGLES WITH STAMPED
END TOWARD TOP OF SECTION

** DIAGONAL ANGLES MUST BE INSTALLED
WITH THE NON-BOLTED FACE UP,
THIS MAY BE ON THE OPPOSITE SIDE OF THE
SIDE PLATE THAN WHAT IS SHOWN IN THE DETAIL.

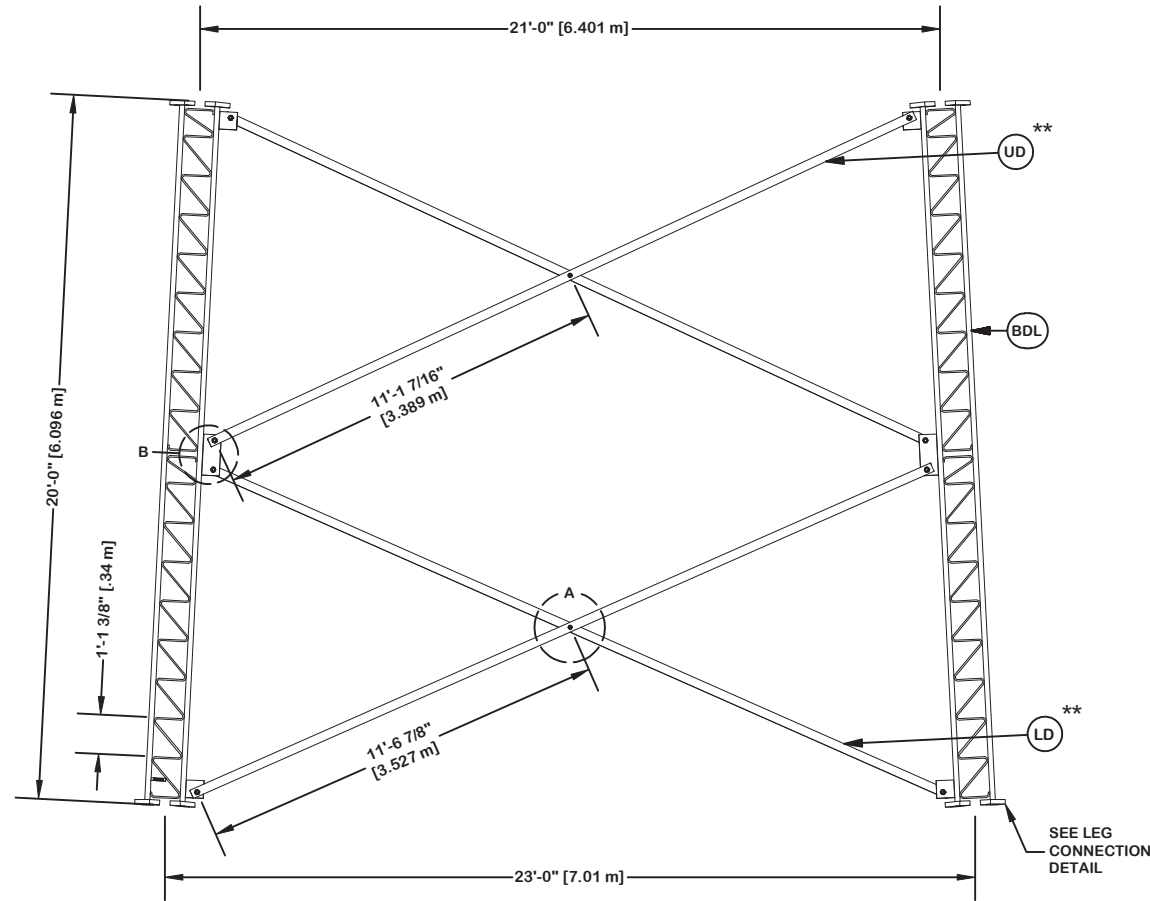

PARTS LIST					
ITEM	QTY	PART NO.	PART DESCRIPTION	UNIT WT.	NET WT.
BDL	3	195217	#12 LEG SECTION - 1-3/4" LEG - 1/2" BRACE - 1" BOL	746.710	2240.130
LD	6	279468	U-24 UPPER DIAGONAL - 4" x 4" x 1/4" ANGLE (A572 G	160.520	963.120
AS	6	104291	RING FILL SPACER 1/2" THICK 1.049" HOLE	0.070	0.420
MN	6	312502	3/4"-10 HOT DIPPED GALVANIZED NUT	0.190	1.140
ML	6	312153	3/4" GALVANIZED LOCKWASHER	0.030	0.180
MB	6	160427	3/4"-10 X 3" A-325T BOLT WITH FULL THREAD	0.470	2.820
SL	24	312223	1" GALVANIZED LOCKWASHER	0.080	1.920
SN	24	312504	1"-8 HOT DIPPED GALVANIZED NUT	0.430	10.320
SB	24	172265	1"-8 X 2-1/4" A-325 BOLT WITH 1-3/4" THREAD	0.840	20.160
UD	6	279427	U-22 LOWER DIAGONAL - 4" x 4" x 1/4" ANGLE (A572 G	154.150	924.900
LCB	18	222022	1-1/4"-7 X 5-1/2" A-325 BOLT WITH 2" THREAD	2.530	45.540
LCF	18	312282	1-1/4" GALVANIZED FLAT WASHER (F436)	0.130	2.340
LCL	18	312283	1-1/4" GALVANIZED LOCKWASHER	0.150	2.700
LCN	18	312507	1-1/4"-7 HOT DIPPED GALVANIZED NUT	0.730	13.140

Total Wt 4228.83 lb [1919.93 kg]

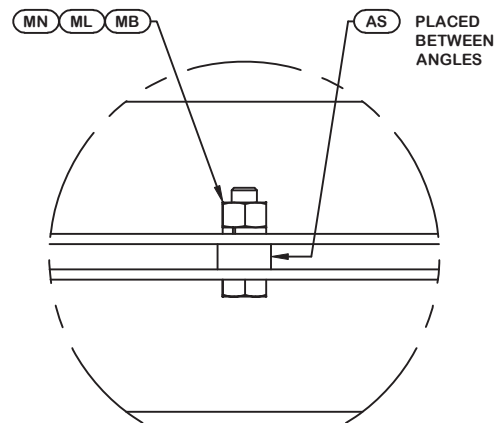

DETAIL A
ANGLE INTERSECTION CONNECTION

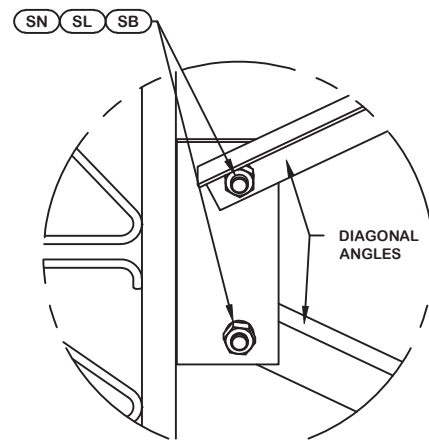

DETAIL B
MID SIDE PLATE ANGLE CONNECTION

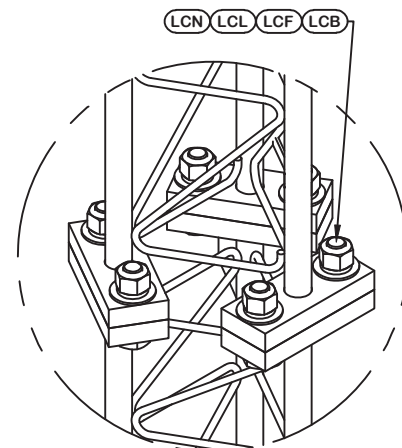

LEG TO LEG CONNECTION
(SIDE PLATES NOT SHOWN FOR CLARITY)



June 1, 2020

REV	DESCRIPTION OF REVISIONS	CPD	BY	DATE
REVISION HISTORY				

SITE	CHATHAM LANDFILL, NC MOTOROLA SOLUTIONS U 35 X 350'
COPYRIGHT 2013	
PROPRIETARY NOTE:	THE DATA AND TECHNIQUES CONTAINED IN THIS DRAWING ARE PROPRIETARY INFORMATION OF VALMONT INDUSTRIES AND CONSIDERED A TRADE SECRET. ANY USE OR DISCLOSURE WITHOUT THE CONSENT OF VALMONT INDUSTRIES IS STRICTLY PROHIBITED.

DESCRIPTION	SECTION U-23.0 (120' - 140' ELEVATION)
STRUCTURE APPROVAL	MVC 5/28/2020
FOUNDATION APPROVAL	

1-877-467-4763 Plymouth, IN 1-800-547-2151 Salem, OR	
ENG. FILE NO.	474445
DWG. NO.	289290T

ORIENT LEGS WITH P/N STAMP
TOWARD BOTTOM OF SECTION

ORIENT ANGLES WITH STAMPED
END TOWARD TOP OF SECTION

** DIAGONAL ANGLES MUST BE INSTALLED
WITH THE NON-BOLTED FACE UP,
THIS MAY BE ON THE OPPOSITE SIDE OF THE
SIDE PLATE THAN WHAT IS SHOWN IN THE DETAIL.

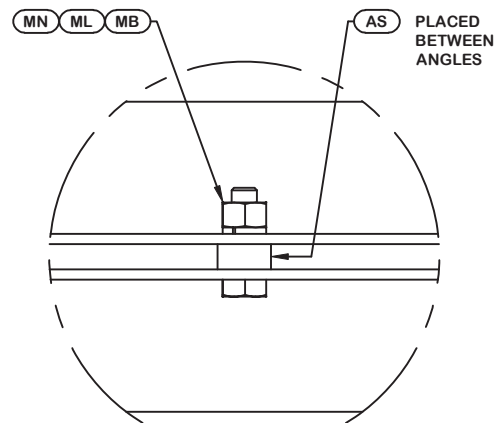
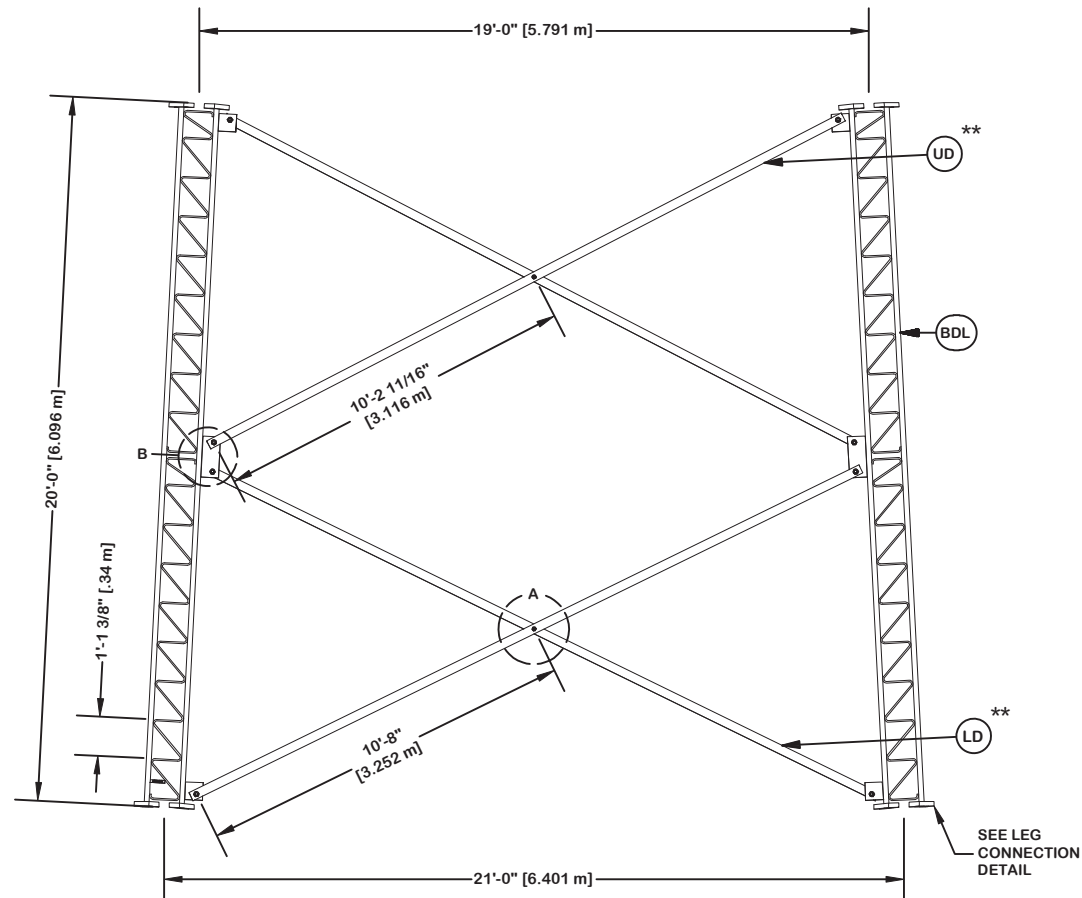

DETAIL A
ANGLE INTERSECTION CONNECTION

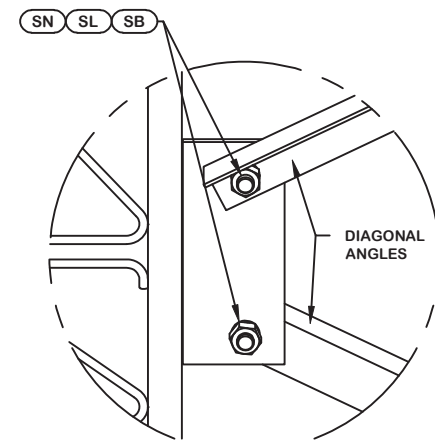

DETAIL B
MID SIDE PLATE ANGLE CONNECTION

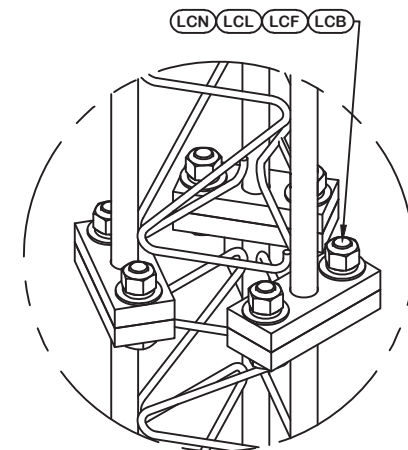

LEG TO LEG CONNECTION
(SIDE PLATES NOT SHOWN FOR CLARITY)

PARTS LIST					
ITEM	QTY	PART NO.	PART DESCRIPTION	UNIT WT.	NET WT.
BDL	3	195213	#12 LEG SECT - 1-3/4" TO 1-1/2" TRANS LEG - 1/2" B	739.890	2219.670
LD	6	279424	U-22 UPPER DIAGONAL - 3 1/2" x 3 1/2" x 5/16" ANGL	159.330	955.980
AS	6	104291	RING FILL SPACER 1/2" THICK 1.049" HOLE	0.070	0.420
MN	6	312502	3/4"-10 HOT DIPPED GALVANIZED NUT	0.190	1.140
ML	6	312153	3/4" GALVANIZED LOCKWASHER	0.030	0.180
MB	6	160427	3/4"-10 X 3" A-325T BOLT WITH FULL THREAD	0.470	2.820
SL	24	312223	1" GALVANIZED LOCKWASHER	0.080	1.920
SN	24	312504	1"-8 HOT DIPPED GALVANIZED NUT	0.430	10.320
SB	24	172265	1"-8 X 2-1/4" A-325 BOLT WITH 1-3/4" THREAD	0.840	20.160
UD	6	279288	U-20 LOWER DIAGONAL - 3 1/2" x 3 1/2" x 5/16" ANGL	152.590	915.540
LCB	18	222022	1-1/4"-7 X 5-1/2" A-325 BOLT WITH 2" THREAD	2.530	45.540
LCF	18	312282	1-1/4" GALVANIZED FLAT WASHER (F436)	0.130	2.340
LCL	18	312283	1-1/4" GALVANIZED LOCKWASHER	0.150	2.700
LCN	18	312507	1-1/4"-7 HOT DIPPED GALVANIZED NUT	0.730	13.140

Total Wt 4191.87 lb [1903.15 kg]



June 1, 2020

REV	DESCRIPTION OF REVISIONS	CPD	BY	DATE
REVISION HISTORY				

<p>SITE</p> <p>CHATHAM LANDFILL, NC MOTOROLA SOLUTIONS U 35 X 350'</p> <p>COPYRIGHT 2013</p> <p>PROPRIETARY NOTE: THE DATA AND TECHNIQUES CONTAINED IN THIS DRAWING ARE PROPRIETARY INFORMATION OF VALMONT INDUSTRIES AND CONSIDERED A TRADE SECRET. ANY USE OR DISCLOSURE WITHOUT THE CONSENT OF VALMONT INDUSTRIES IS STRICTLY PROHIBITED.</p>
--

<p>DESCRIPTION</p> <p>SECTION U-21.0 (140' - 160' ELEVATION)</p>
<p>STRUCTURE APPROVAL</p> <p>MVC 5/28/2020</p>
<p>FOUNDATION APPROVAL</p>

<p>valmont </p> <p>1-877-467-4763 Plymouth, IN 1-800-547-2151 Salem, OR</p> <p>STRUCTURES</p>
<p>ENG. FILE NO.</p> <p>474445</p>
<p>DWG. NO.</p> <p>289290T</p>

ORIENT LEGS WITH P/N STAMP
TOWARD BOTTOM OF SECTION

ORIENT ANGLES WITH STAMPED
END TOWARD TOP OF SECTION

** DIAGONAL ANGLES MUST BE INSTALLED
WITH THE NON-BOLTED FACE UP,
THIS MAY BE ON THE OPPOSITE SIDE OF THE
SIDE PLATE THAN WHAT IS SHOWN IN THE DETAIL.

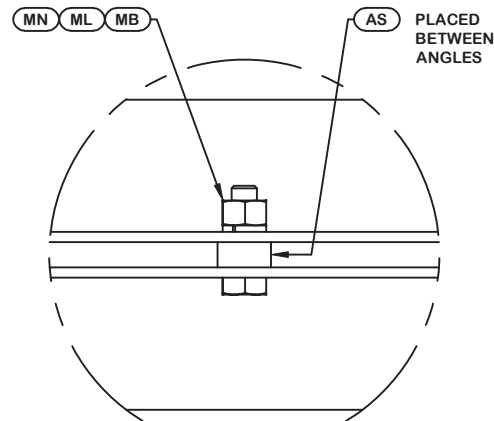
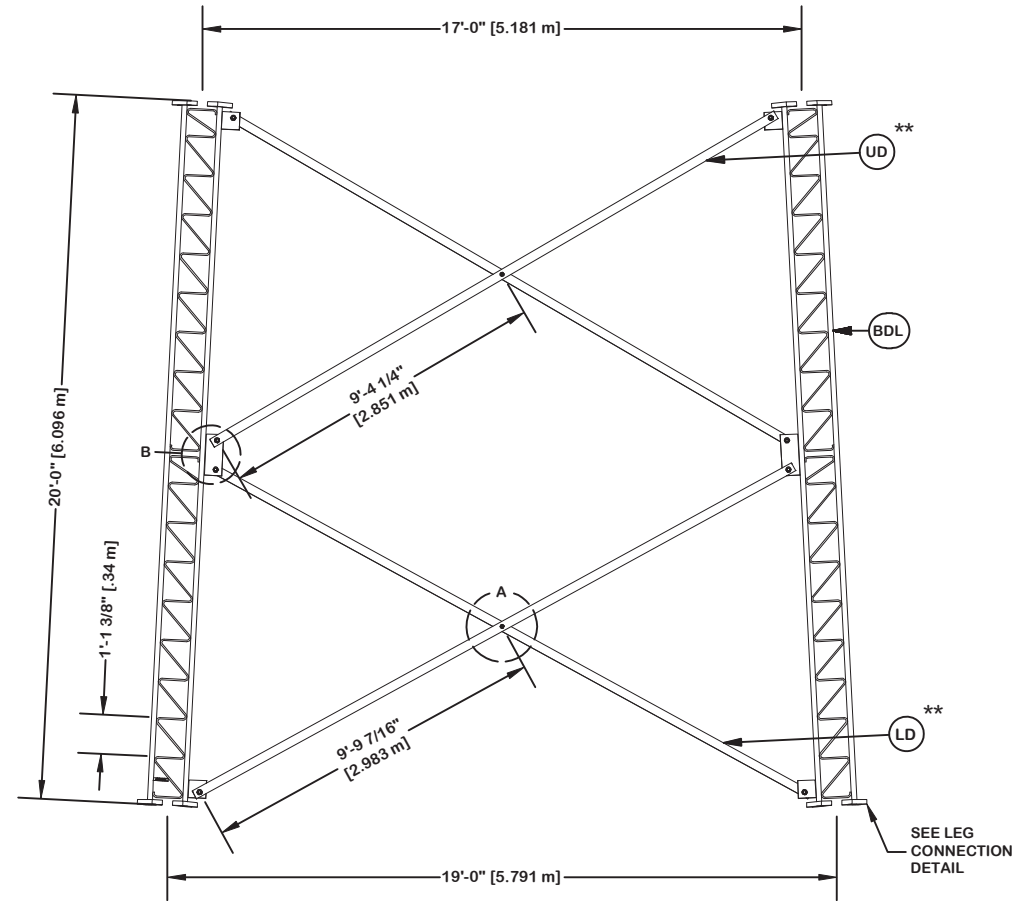

DETAIL A
ANGLE INTERSECTION CONNECTION

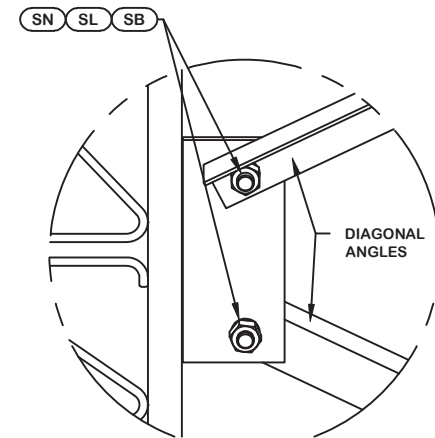

DETAIL B
MID SIDE PLATE ANGLE CONNECTION

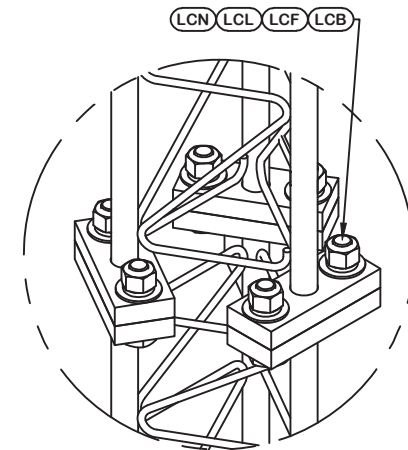

LEG TO LEG CONNECTION
(SIDE PLATES NOT SHOWN FOR CLARITY)

PARTS LIST					
ITEM	QTY	PART NO.	PART DESCRIPTION	UNIT WT.	NET WT.
BDL	3	194651	#12 LEG SECTION - 1-1/2" LEG - 1/2" BRACE - 1" BOL	602.830	1808.490
LD	6	279285	U-20 UPPER DIAGONAL - 3 1/2" x 3 1/2" x 1/4" ANGLE	118.070	708.420
AS	6	104291	RING FILL SPACER 1/2" THICK 1.049" HOLE	0.070	0.420
MN	6	312502	3/4"-10 HOT DIPPED GALVANIZED NUT	0.190	1.140
ML	6	312153	3/4" GALVANIZED LOCKWASHER	0.030	0.180
MB	6	160427	3/4"-10 X 3" A-325T BOLT WITH FULL THREAD	0.470	2.820
SL	24	312223	1" GALVANIZED LOCKWASHER	0.080	1.920
SN	24	312504	1"-8 HOT DIPPED GALVANIZED NUT	0.430	10.320
SB	24	172265	1"-8 X 2-1/4" A-325 BOLT WITH 1-3/4" THREAD	0.840	20.160
UD	6	279271	U-18 LOWER DIAGONAL - 3 1/2" x 3 1/2" x 1/4" ANGLE	112.760	676.560
LCB	18	222016	1"-8 X 4-3/4" A-325 BOLT WITH 1-3/4" THREAD	1.380	24.840
LCF	18	312222	1" GALVANIZED FLAT WASHER (F436)	0.140	2.520
LCL	18	312223	1" GALVANIZED LOCKWASHER	0.080	1.440
LCN	18	312504	1"-8 HOT DIPPED GALVANIZED NUT	0.430	7.740

Total Wt 3266.97 lb [1483.23 kg]



June 1, 2020

REV	DESCRIPTION OF REVISIONS	CPD	BY	DATE
REVISION HISTORY				

<p>SITE</p> <p>CHATHAM LANDFILL, NC MOTOROLA SOLUTIONS U 35 X 350'</p> <p>COPYRIGHT 2013</p> <p>PROPRIETARY NOTE: THE DATA AND TECHNIQUES CONTAINED IN THIS DRAWING ARE PROPRIETARY INFORMATION OF VALMONT INDUSTRIES AND CONSIDERED A TRADE SECRET. ANY USE OR DISCLOSURE WITHOUT THE CONSENT OF VALMONT INDUSTRIES IS STRICTLY PROHIBITED.</p>

<p>DESCRIPTION</p> <p>SECTION U-19.0 (160' - 180' ELEVATION)</p>
<p>STRUCTURE APPROVAL</p> <p>MVC 5/28/2020</p>

<p>valmont </p> <p>1-877-467-4763 Plymouth, IN 1-800-547-2151 Salem, OR</p> <p>STRUCTURES</p>	
<p>ENG. FILE NO.</p> <p>474445</p>	<p>DWG. NO.</p> <p>289290T</p>
<p>FOUNDATION APPROVAL</p>	

ORIENT LEGS WITH P/N STAMP
TOWARD BOTTOM OF SECTION

ORIENT ANGLES WITH STAMPED
END TOWARD TOP OF SECTION

** DIAGONAL ANGLES MUST BE INSTALLED
WITH THE NON-BOLTED FACE UP, ↑↑
THIS MAY BE ON THE OPPOSITE SIDE OF THE
SIDE PLATE THAN WHAT IS SHOWN IN THE DETAIL.

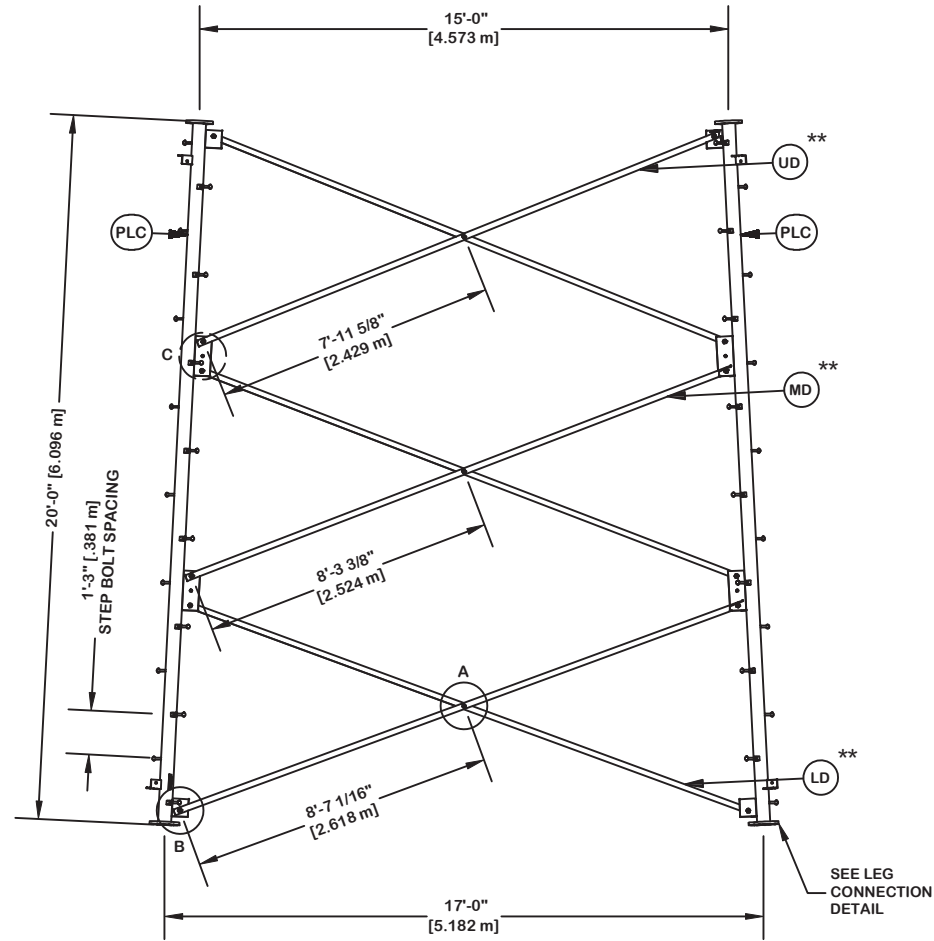

PARTS LIST					
ITEM	QTY	PART NO.	PART DESCRIPTION	UNIT WT.	NET WT.
PLC	3	229377	PIPE LEG SECTION 20'-0" (CLIMBING) 6" SCH. 40 V-SE	537.940	1613.820
STP	48	228189	STEP BOLT ASSY 5/8"-11 X 7" W/ LOCK WASHER HEAVY	1.100	52.800
LD	6	284844	V-17 LOWER CLIPPED ANGLE - 3" x 3" x 3/16" ANGLE (66.540	399.240
MB	9	227580	5/8"-11 X 2-1/4" A325T HOT DIPPED GALV. BOLT (FULL	0.640	5.760
AS	9	124838	MID-DIAGONAL SPACER 11/16" HOLE 3/8" THICK	0.450	4.050
MN	9	312501	5/8"-11 HOT DIPPED GALVANIZED NUT	0.120	1.080
ML	9	312123	5/8" GALVANIZED LOCKWASHER (53-22230)	0.020	0.180
SL	36	312153	3/4" GALVANIZED LOCKWASHER	0.030	1.080
SN	36	312502	3/4"-10 HOT DIPPED GALVANIZED NUT	0.190	6.840
SB	36	227579	3/4"-10 X 2-1/4" A-325T BOLT WITH FULL THREAD	0.420	15.120
MD	6	284843	V-17 MID ANGLE - 3" x 3" x 3/16" ANGLE (A572 GR. 5	64.300	385.800
UD	6	284842	V-17 UPPER ANGLE - 3" x 3" x 3/16" ANGLE (A572 GR.	61.860	371.160
LCB	18	172272	1"-8 X 4-1/4" A-325 BOLT WITH 1-3/4" THREAD	0.840	15.120
LCF	18	312222	1" GALVANIZED FLAT WASHER (F436)	0.140	2.520
LCL	18	312223	1" GALVANIZED LOCKWASHER	0.080	1.440
LCN	18	312504	1"-8 HOT DIPPED GALVANIZED NUT	0.430	7.740
Total Wt				2883.75 lb [1309.25 kg]	

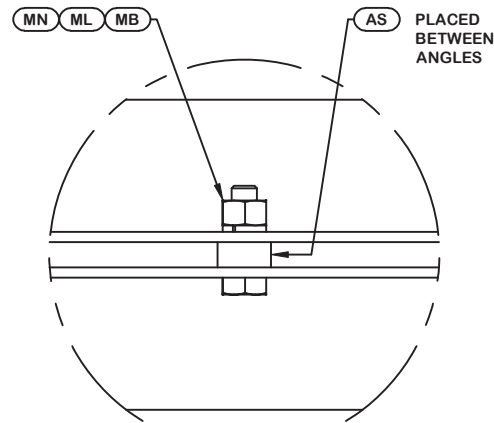

DETAIL A
ANGLE INTERSECTION CONNECTION

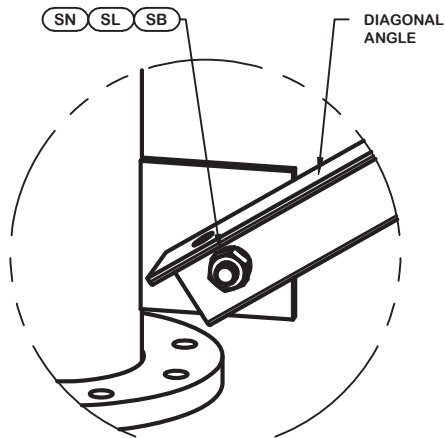

DETAIL B
END SIDE PLATE ANGLE CONNECTION

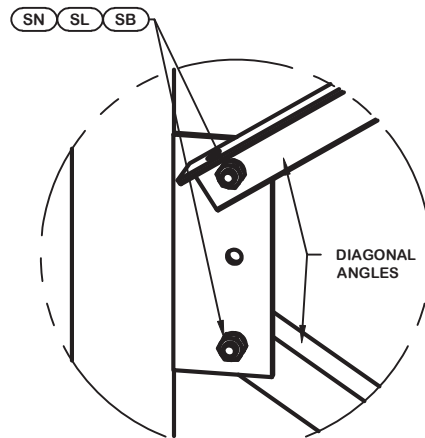

DETAIL C
MID SIDE PLATE ANGLE CONNECTION

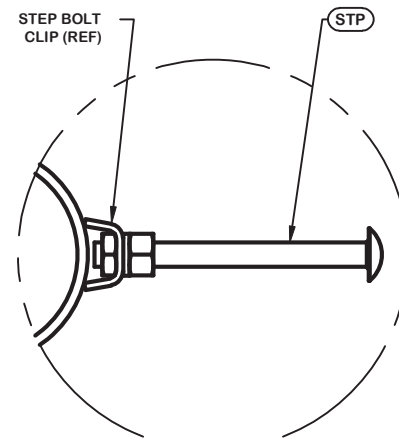

STEP BOLT INSTALLATION

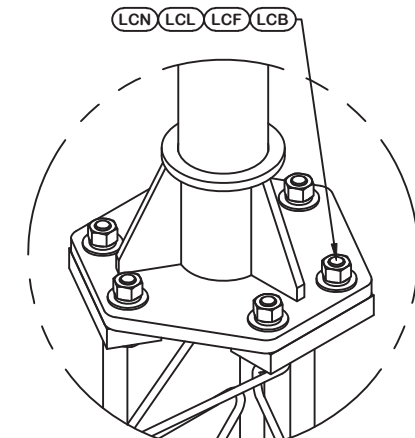

LEG TO LEG CONNECTION
(SIDE PLATES NOT SHOWN FOR CLARITY)



June 1, 2020

REV	DESCRIPTION OF REVISIONS	CPD	BY	DATE
REVISION HISTORY				

SITE	CHATHAM LANDFILL, NC MOTOROLA SOLUTIONS U 35 X 350'
COPYRIGHT 2013	
PROPRIETARY NOTE:	THE DATA AND TECHNIQUES CONTAINED IN THIS DRAWING ARE PROPRIETARY INFORMATION OF VALMONT INDUSTRIES AND CONSIDERED A TRADE SECRET. ANY USE OR DISCLOSURE WITHOUT THE CONSENT OF VALMONT INDUSTRIES IS STRICTLY PROHIBITED.

DESCRIPTION	SECTION V-17.0 (180' - 200' ELEVATION)
STRUCTURE APPROVAL	MVC 5/28/2020
FOUNDATION APPROVAL	

valmont	
1-877-467-4763 Plymouth, IN 1-800-547-2151 Salem, OR	
ENG. FILE NO.	474445
DWG. NO.	289290T
PAGE 12 OF 20	

ORIENT LEGS WITH P/N STAMP
TOWARD BOTTOM OF SECTION

ORIENT ANGLES WITH STAMPED
END TOWARD TOP OF SECTION

** DIAGONAL ANGLES MUST BE INSTALLED
WITH THE NON-BOLTED FACE UP, ↑
THIS MAY BE ON THE OPPOSITE SIDE OF THE
SIDE PLATE THAN WHAT IS SHOWN IN THE DETAIL.

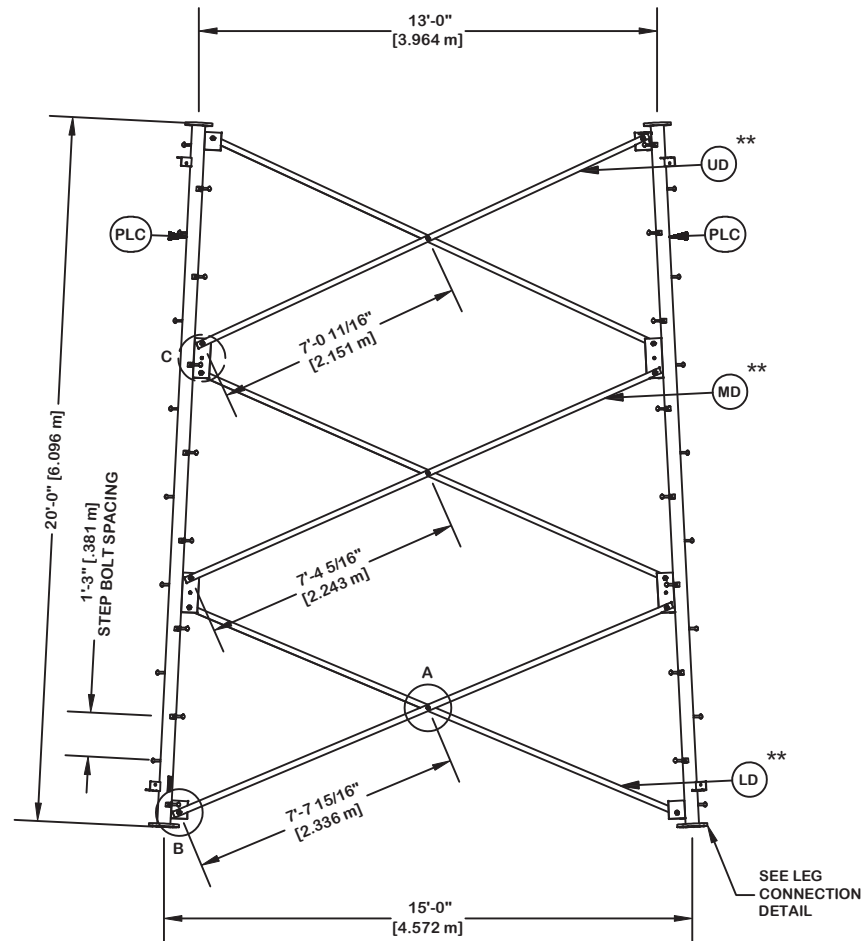

PARTS LIST					
ITEM	QTY	PART NO.	PART DESCRIPTION	UNIT WT.	NET WT.
PLC	3	226192	PIPE LEG SECTION 20'-0" (CLIMBING) 5" SCH. 40 V-SE	396.130	1188.390
STP	48	228189	STEP BOLT ASSY 5/8"-11 X 7" W/ LOCK WASHER HEAVY	1.100	52.800
LD	6	284820	V-15 LOWER CLIPPED ANGLE - 2 1/2" x 2 1/2" x 3/16"	49.150	294.900
MB	9	227580	5/8"-11 X 2-1/4" A325T HOT DIPPED GALV. BOLT (FULL	0.640	5.760
AS	9	124838	MID-DIAGONAL SPACER 1 1/16" HOLE 3/8" THICK	0.450	4.050
MN	9	312501	5/8"-11 HOT DIPPED GALVANIZED NUT	0.120	1.080
ML	9	312123	5/8" GALVANIZED LOCKWASHER (53-22230)	0.020	0.180
SL	36	312153	3/4" GALVANIZED LOCKWASHER	0.030	1.080
SN	36	312502	3/4"-10 HOT DIPPED GALVANIZED NUT	0.190	6.840
SB	36	227579	3/4"-10 X 2-1/4" A-325T BOLT WITH FULL THREAD	0.420	15.120
MD	6	284819	V-15 MID ANGLE - 2 1/2" x 2 1/2" x 3/16" ANGLE (A5	47.310	283.860
UD	6	284818	V-15 UPPER ANGLE - 2 1/2" x 2 1/2" x 3/16" ANGLE (45.330	271.980
LCB	24	227668	3/4"-10 X 3-1/2" A-325T BOLT WITH FULL THREAD	0.540	12.960
LCF	24	312152	3/4" GALVANIZED FLAT WASHER (F436)	0.080	1.920
LCL	24	312153	3/4" GALVANIZED LOCKWASHER	0.030	0.720
LCN	24	312502	3/4"-10 HOT DIPPED GALVANIZED NUT	0.190	4.560
Total Wt				2146.20 lb [974.39 kg]	

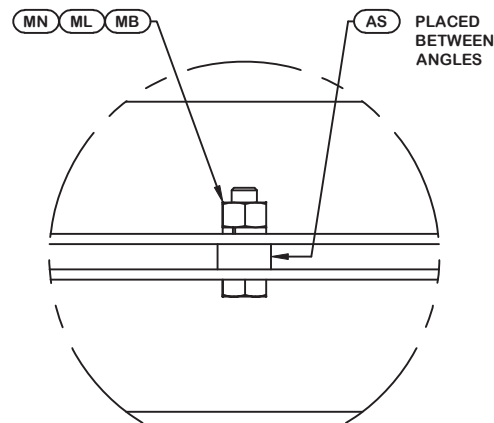

DETAIL A
ANGLE INTERSECTION CONNECTION

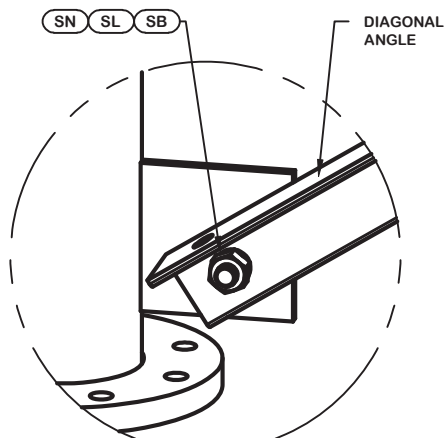

DETAIL B
END SIDE PLATE ANGLE CONNECTION

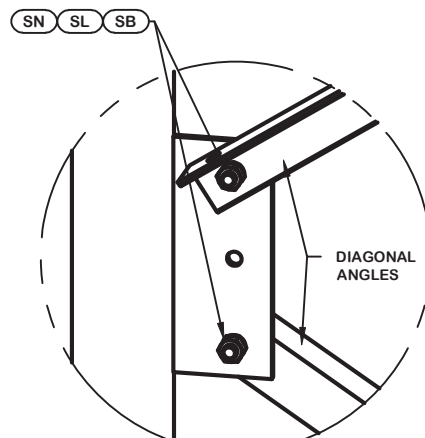

DETAIL C
MID SIDE PLATE ANGLE CONNECTION

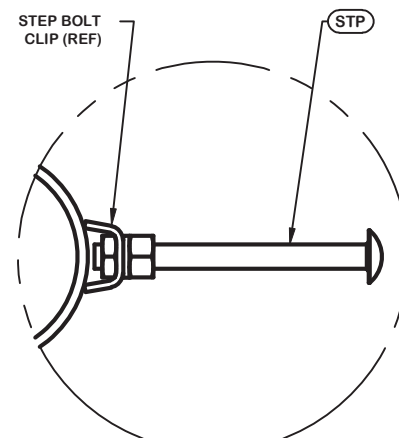

STEP BOLT INSTALLATION

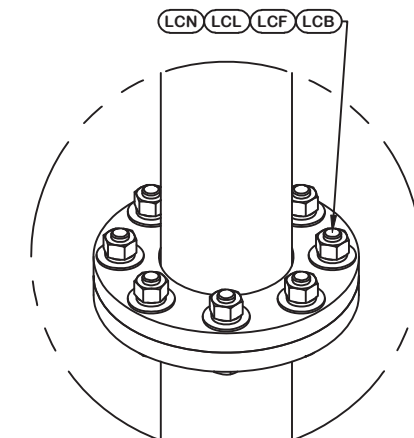

LEG TO LEG CONNECTION
(SIDE PLATES NOT SHOWN FOR CLARITY)



June 1, 2020

REV	DESCRIPTION OF REVISIONS	CPD	BY	DATE
REVISION HISTORY				

SITE	CHATHAM LANDFILL, NC MOTOROLA SOLUTIONS U 35 X 350'
COPYRIGHT 2013	
PROPRIETARY NOTE:	THE DATA AND TECHNIQUES CONTAINED IN THIS DRAWING ARE PROPRIETARY INFORMATION OF VALMONT INDUSTRIES AND CONSIDERED A TRADE SECRET. ANY USE OR DISCLOSURE WITHOUT THE CONSENT OF VALMONT INDUSTRIES IS STRICTLY PROHIBITED.

DESCRIPTION	SECTION V-15.0 (200' - 220' ELEVATION)
STRUCTURE APPROVAL	MVC 5/28/2020
FOUNDATION APPROVAL	

valmont	
1-877-467-4763 Plymouth, IN 1-800-547-2151 Salem, OR	
ENG. FILE NO.	474445
DWG. NO.	289290T

ORIENT LEGS WITH P/N STAMP
TOWARD BOTTOM OF SECTION

ORIENT ANGLES WITH STAMPED
END TOWARD TOP OF SECTION

** DIAGONAL ANGLES MUST BE INSTALLED
WITH THE NON-BOLTED FACE UP, ↑
THIS MAY BE ON THE OPPOSITE SIDE OF THE
SIDE PLATE THAN WHAT IS SHOWN IN THE DETAIL.

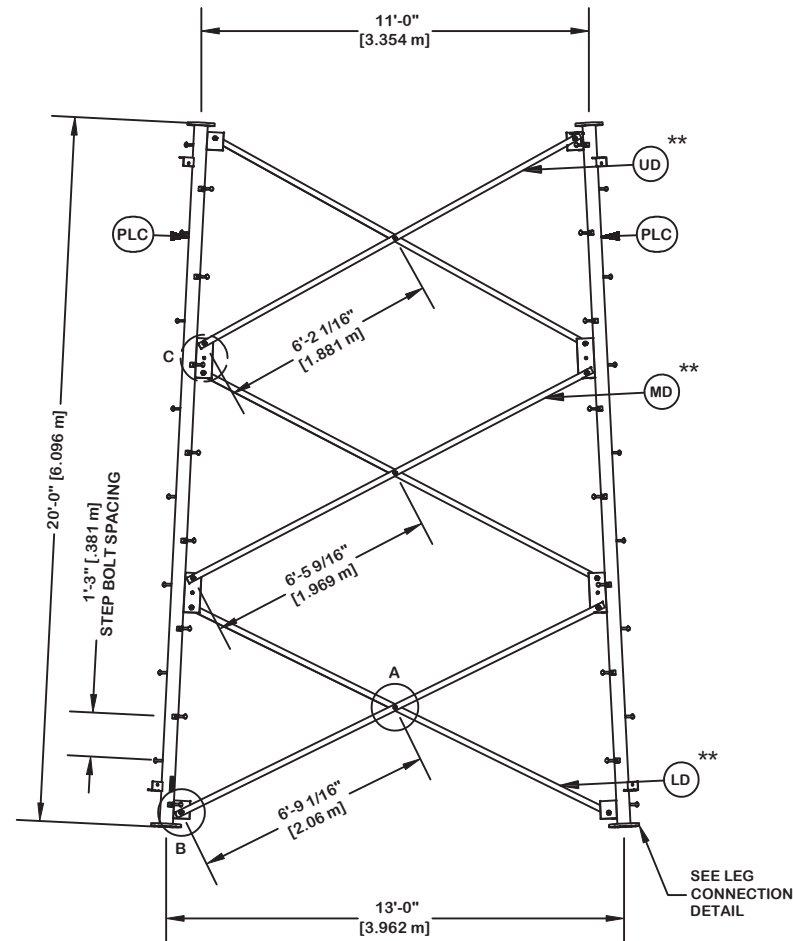

PARTS LIST					
ITEM	QTY	PART NO.	PART DESCRIPTION	UNIT WT.	NET WT.
PLC	3	226192	PIPE LEG SECTION 20'-0" (CLIMBING) 5" SCH. 40 V-SE	396.130	1188.390
STP	48	228189	STEP BOLT ASSY 5/8"-11 X 7" W/ LOCK WASHER HEAVY	1.100	52.800
LD	6	284799	V-13 LOWER CLIPPED ANGLE - 2 1/2" x 2 1/2" x 3/16"	43.220	259.320
MB	9	227580	5/8"-11 X 2-1/4" A325T HOT DIPPED GALV. BOLT (FULL	0.640	5.760
AS	9	124838	MID-DIAGONAL SPACER 1 1/16" HOLE 3/8" THICK	0.450	4.050
MN	9	312501	5/8"-11 HOT DIPPED GALVANIZED NUT	0.120	1.080
ML	9	312123	5/8" GALVANIZED LOCKWASHER (53-22230)	0.020	0.180
SL	36	312153	3/4" GALVANIZED LOCKWASHER	0.030	1.080
SN	36	312502	3/4"-10 HOT DIPPED GALVANIZED NUT	0.190	6.840
SB	36	227579	3/4"-10 X 2-1/4" A-325T BOLT WITH FULL THREAD	0.420	15.120
MD	6	284798	V-13 MID ANGLE - 2 1/2" x 2 1/2" x 3/16" ANGLE (A5	41.430	248.580
UD	6	284797	V-13 UPPER ANGLE - 2 1/2" x 2 1/2" x 3/16" ANGLE (39.520	237.120
LCB	24	227668	3/4"-10 X 3-1/2" A-325T BOLT WITH FULL THREAD	0.540	12.960
LCF	24	312152	3/4" GALVANIZED FLAT WASHER (F436)	0.080	1.920
LCL	24	312153	3/4" GALVANIZED LOCKWASHER	0.030	0.720
LCN	24	312502	3/4"-10 HOT DIPPED GALVANIZED NUT	0.190	4.560
Total Wt				2040.48 lb [926.40 kg]	

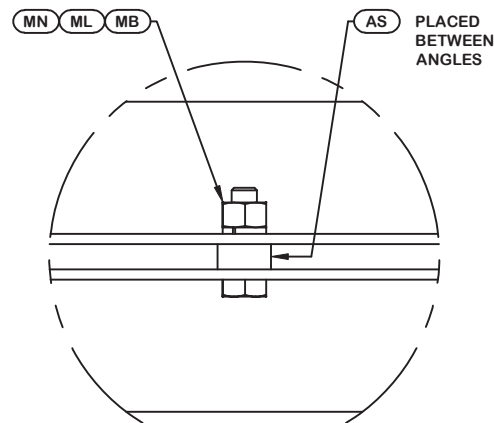

DETAIL A
ANGLE INTERSECTION CONNECTION

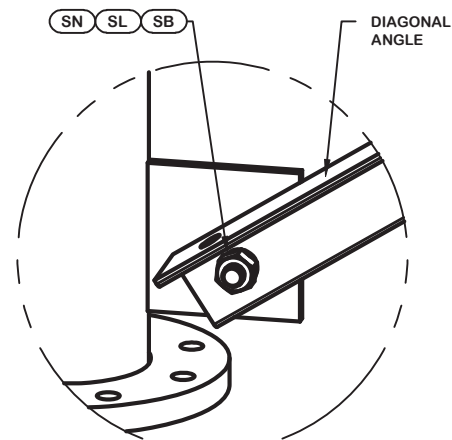

DETAIL B
END SIDE PLATE ANGLE CONNECTION

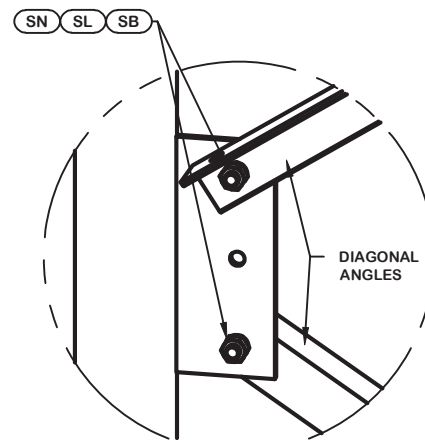

DETAIL C
MID SIDE PLATE ANGLE CONNECTION

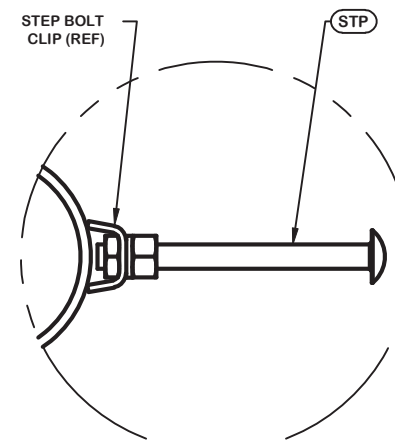

STEP BOLT INSTALLATION

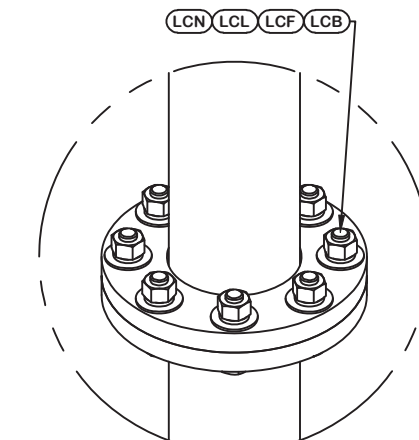

LEG TO LEG CONNECTION
(SIDE PLATES NOT SHOWN FOR CLARITY)



June 1, 2020

REV	DESCRIPTION OF REVISIONS	CPD	BY	DATE
REVISION HISTORY				

SITE	CHATHAM LANDFILL, NC MOTOROLA SOLUTIONS U 35 X 350'
COPYRIGHT 2013	
PROPRIETARY NOTE:	THE DATA AND TECHNIQUES CONTAINED IN THIS DRAWING ARE PROPRIETARY INFORMATION OF VALMONT INDUSTRIES AND CONSIDERED A TRADE SECRET. ANY USE OR DISCLOSURE WITHOUT THE CONSENT OF VALMONT INDUSTRIES IS STRICTLY PROHIBITED.

DESCRIPTION	SECTION V-13.0 (220' - 240' ELEVATION)
STRUCTURE APPROVAL	MVC 5/28/2020
FOUNDATION APPROVAL	

valmont	
1-877-467-4763 Plymouth, IN 1-800-547-2151 Salem, OR	
ENG. FILE NO.	474445
DWG. NO.	289290T

ORIENT LEGS WITH P/N STAMP
TOWARD BOTTOM OF SECTION

ORIENT ANGLES WITH STAMPED
END TOWARD TOP OF SECTION

** DIAGONAL ANGLES MUST BE INSTALLED
WITH THE NON-BOLTED FACE UP, ↑
THIS MAY BE ON THE OPPOSITE SIDE OF THE
SIDE PLATE THAN WHAT IS SHOWN IN THE DETAIL.

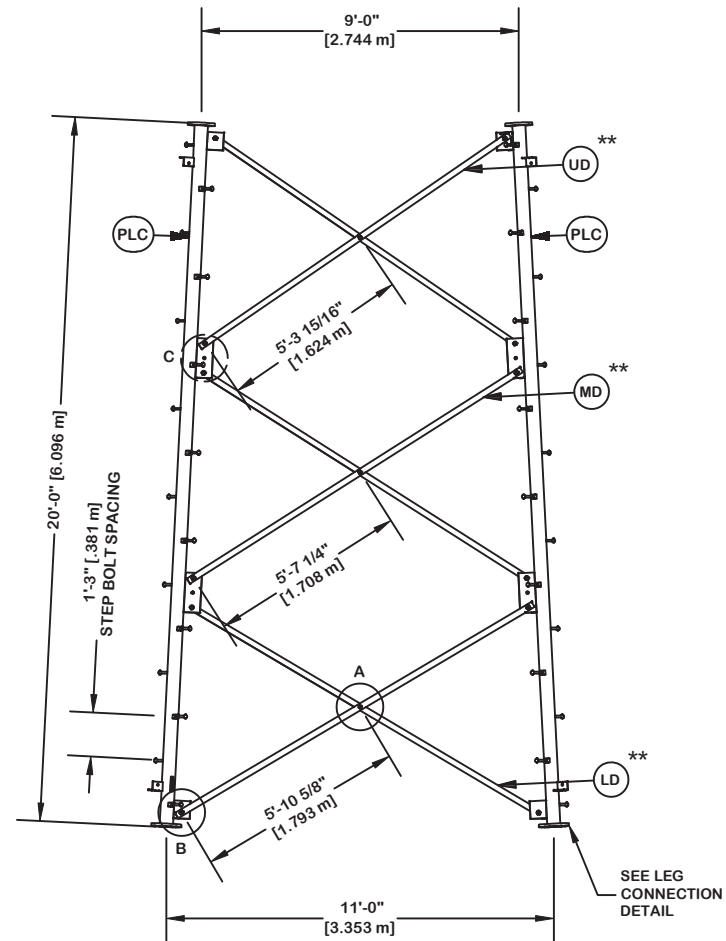

PARTS LIST					
ITEM	QTY	PART NO.	PART DESCRIPTION	UNIT WT.	NET WT.
PLC	3	226192	PIPE LEG SECTION 20'-0" (CLIMBING) 5" SCH. 40 V-SE	396.130	1188.390
STP	48	228189	STEP BOLT ASSY 5/8"-11 X 7" W/ LOCK WASHER HEAVY	1.100	52.800
LD	6	284775	V-11 LOWER CLIPPED ANGLE - 2" x 2" x 3/16" ANGLE (29.650	177.900
MB	9	227580	5/8"-11 X 2-1/4" A325T HOT DIPPED GALV. BOLT (FULL	0.640	5.760
AS	9	124838	MID-DIAGONAL SPACER 11/16" HOLE 3/8" THICK	0.450	4.050
MN	9	312501	5/8"-11 HOT DIPPED GALVANIZED NUT	0.120	1.080
ML	9	312123	5/8" GALVANIZED LOCKWASHER (53-22230)	0.020	0.180
SL	36	312153	3/4" GALVANIZED LOCKWASHER	0.030	1.080
SN	36	312502	3/4"-10 HOT DIPPED GALVANIZED NUT	0.190	6.840
SB	36	227579	3/4"-10 X 2-1/4" A-325T BOLT WITH FULL THREAD	0.420	15.120
MD	6	284774	V-11 MID ANGLE - 2" x 2" x 3/16" ANGLE (A572 GR. 5	28.290	169.740
UD	6	284773	V-11 UPPER ANGLE - 2" x 2" x 3/16" ANGLE (A572 GR.	26.860	161.160
LCB	24	227668	3/4"-10 X 3-1/2" A-325T BOLT WITH FULL THREAD	0.540	12.960
LCF	24	312152	3/4" GALVANIZED FLAT WASHER (F436)	0.080	1.920
LCL	24	312153	3/4" GALVANIZED LOCKWASHER	0.030	0.720
LCN	24	312502	3/4"-10 HOT DIPPED GALVANIZED NUT	0.190	4.560
Total Wt				1804.26 lb [819.15 kg]	

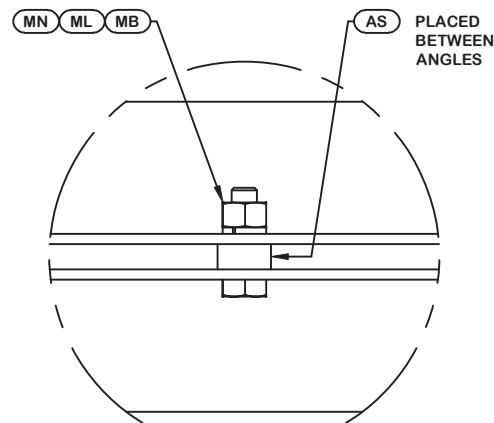

DETAIL A
ANGLE INTERSECTION CONNECTION

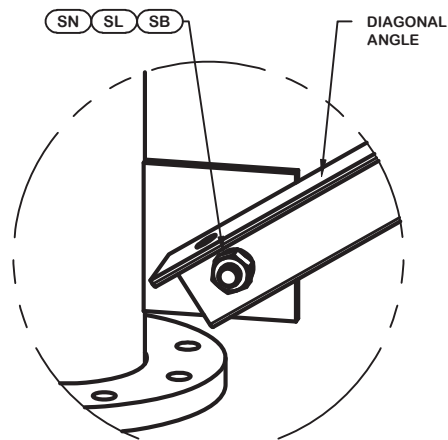

DETAIL B
END SIDE PLATE ANGLE CONNECTION

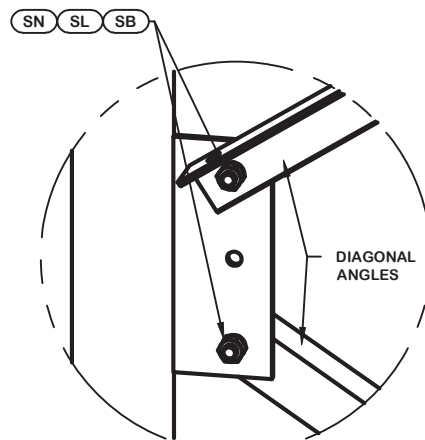

DETAIL C
MID SIDE PLATE ANGLE CONNECTION

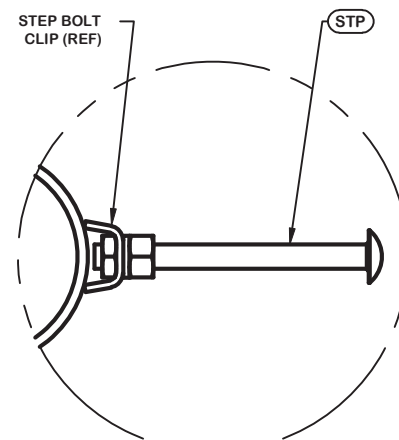

STEP BOLT INSTALLATION

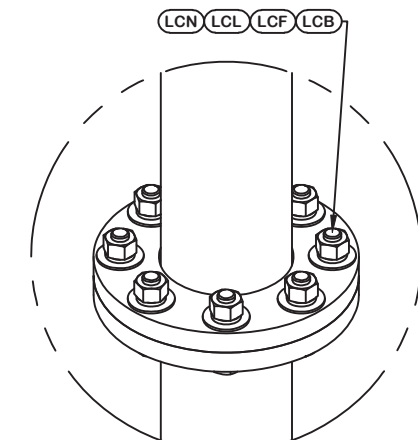

LEG TO LEG CONNECTION
(SIDE PLATES NOT SHOWN FOR CLARITY)



June 1, 2020

REV	DESCRIPTION OF REVISIONS	CPD	BY	DATE
REVISION HISTORY				

SITE	CHATHAM LANDFILL, NC MOTOROLA SOLUTIONS U 35 X 350'
COPYRIGHT 2013	
PROPRIETARY NOTE:	THE DATA AND TECHNIQUES CONTAINED IN THIS DRAWING ARE PROPRIETARY INFORMATION OF VALMONT INDUSTRIES AND CONSIDERED A TRADE SECRET. ANY USE OR DISCLOSURE WITHOUT THE CONSENT OF VALMONT INDUSTRIES IS STRICTLY PROHIBITED.

DESCRIPTION	SECTION V-11.0 (240' - 260' ELEVATION)
STRUCTURE APPROVAL	MVC 5/28/2020
FOUNDATION APPROVAL	

valmont	
1-877-467-4763 Plymouth, IN 1-800-547-2151 Salem, OR	
STRUCTURES	
ENG. FILE NO.	474445
DWG. NO.	289290T

ORIENT LEGS WITH P/N STAMP
TOWARD BOTTOM OF SECTION

ORIENT ANGLES WITH STAMPED
END TOWARD TOP OF SECTION

** DIAGONAL ANGLES MUST BE INSTALLED
WITH THE NON-BOLTED FACE UP, ↑↑
THIS MAY BE ON THE OPPOSITE SIDE OF THE
SIDE PLATE THAN WHAT IS SHOWN IN THE DETAIL.

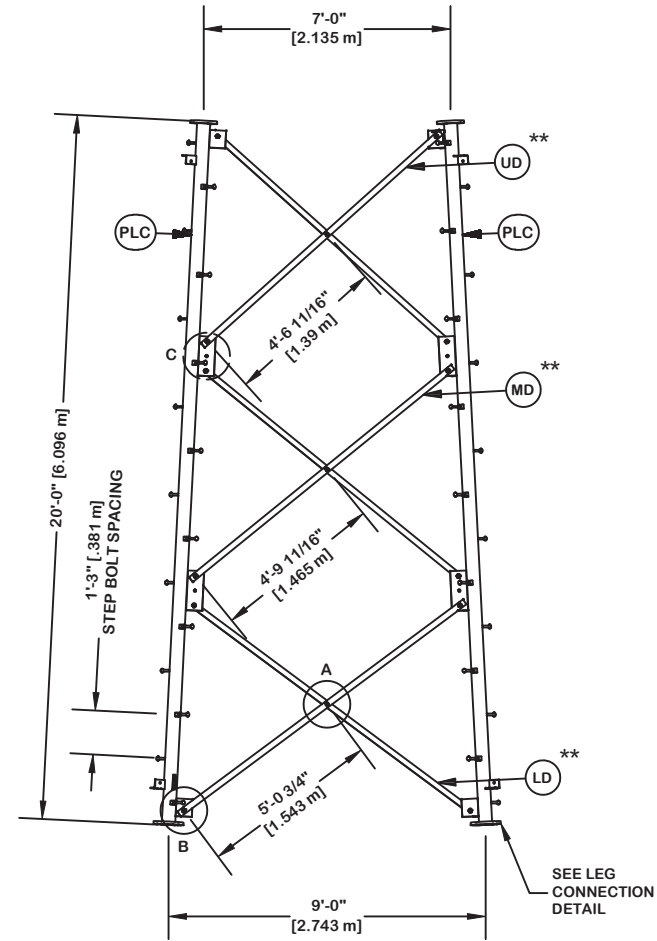

PARTS LIST					
ITEM	QTY	PART NO.	PART DESCRIPTION	UNIT WT.	NET WT.
PLC	3	226192	PIPE LEG SECTION 20'-0" (CLIMBING) 5" SCH. 40 V-SE	396.130	1188.390
STP	48	228189	STEP BOLT ASSY 5/8"-11 X 7" W/ LOCK WASHER HEAVY	1.100	52.800
LD	6	284754	V-9 LOWER CLIPPED ANGLE - 2" X 2" X 3/16" ANGLE (A)	25.380	152.280
MB	9	227580	5/8"-11 X 2-1/4" A325T HOT DIPPED GALV. BOLT (FULL	0.640	5.760
AS	9	124838	MID-DIAGONAL SPACER 11/16" HOLE 3/8" THICK	0.450	4.050
MN	9	312501	5/8"-11 HOT DIPPED GALVANIZED NUT	0.120	1.080
ML	9	312123	5/8" GALVANIZED LOCKWASHER (53-22230)	0.020	0.180
SL	36	312153	3/4" GALVANIZED LOCKWASHER	0.030	1.080
SN	36	312502	3/4"-10 HOT DIPPED GALVANIZED NUT	0.190	6.840
SB	36	227579	3/4"-10 X 2-1/4" A-325T BOLT WITH FULL THREAD	0.420	15.120
MD	6	284753	V-9 MID ANGLE - 2" X 2" X 3/16" ANGLE (A572 GR. 50	24.120	144.720
UD	6	284752	V-9 UPPER ANGLE - 2" X 2" X 3/16" ANGLE (A572 GR.	22.830	136.980
LCB	24	227668	3/4"-10 X 3-1/2" A-325T BOLT WITH FULL THREAD	0.540	12.960
LCF	24	312152	3/4" GALVANIZED FLAT WASHER (F436)	0.080	1.920
LCL	24	312153	3/4" GALVANIZED LOCKWASHER	0.030	0.720
LCN	24	312502	3/4"-10 HOT DIPPED GALVANIZED NUT	0.190	4.560
Total Wt				1729.44 lb [785.18 kg]	

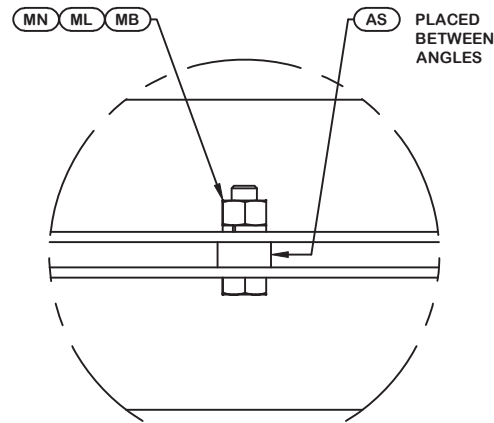

DETAIL A
ANGLE INTERSECTION CONNECTION

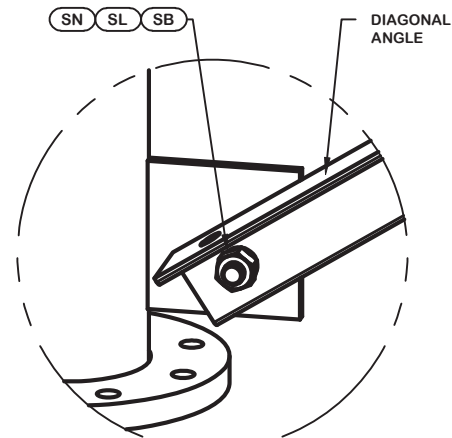

DETAIL B
END SIDE PLATE ANGLE CONNECTION

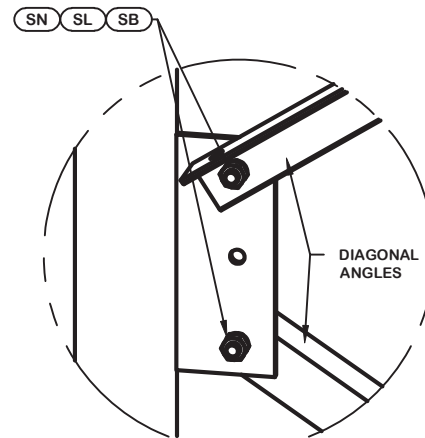

DETAIL C
MID SIDE PLATE ANGLE CONNECTION

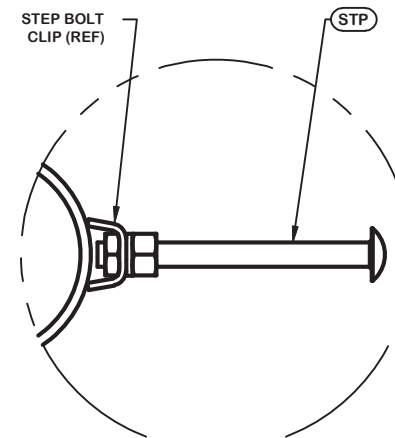

STEP BOLT INSTALLATION

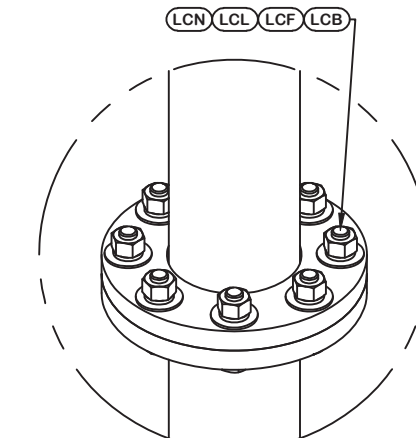

LEG TO LEG CONNECTION
(SIDE PLATES NOT SHOWN FOR CLARITY)



June 1, 2020

REV	DESCRIPTION OF REVISIONS	CPD	BY	DATE
REVISION HISTORY				

SITE	CHATHAM LANDFILL, NC MOTOROLA SOLUTIONS U 35 X 350'
COPYRIGHT 2013	
PROPRIETARY NOTE:	THE DATA AND TECHNIQUES CONTAINED IN THIS DRAWING ARE PROPRIETARY INFORMATION OF VALMONT INDUSTRIES AND CONSIDERED A TRADE SECRET. ANY USE OR DISCLOSURE WITHOUT THE CONSENT OF VALMONT INDUSTRIES IS STRICTLY PROHIBITED.

DESCRIPTION	SECTION V-9.0 (260' - 280' ELEVATION)
STRUCTURE APPROVAL	MVC 5/28/2020
FOUNDATION APPROVAL	

valmont	
1-877-467-4763 Plymouth, IN 1-800-547-2151 Salem, OR	
STRUCTURES	
ENG. FILE NO.	474445
DWG. NO.	289290T

ORIENT LEGS WITH P/N STAMP
TOWARD BOTTOM OF SECTION

ORIENT ANGLES WITH STAMPED
END TOWARD TOP OF SECTION

** DIAGONAL ANGLES MUST BE INSTALLED
WITH THE NON-BOLTED FACE UP, ↑↑
THIS MAY BE ON THE OPPOSITE SIDE OF THE
SIDE PLATE THAN WHAT IS SHOWN IN THE DETAIL.

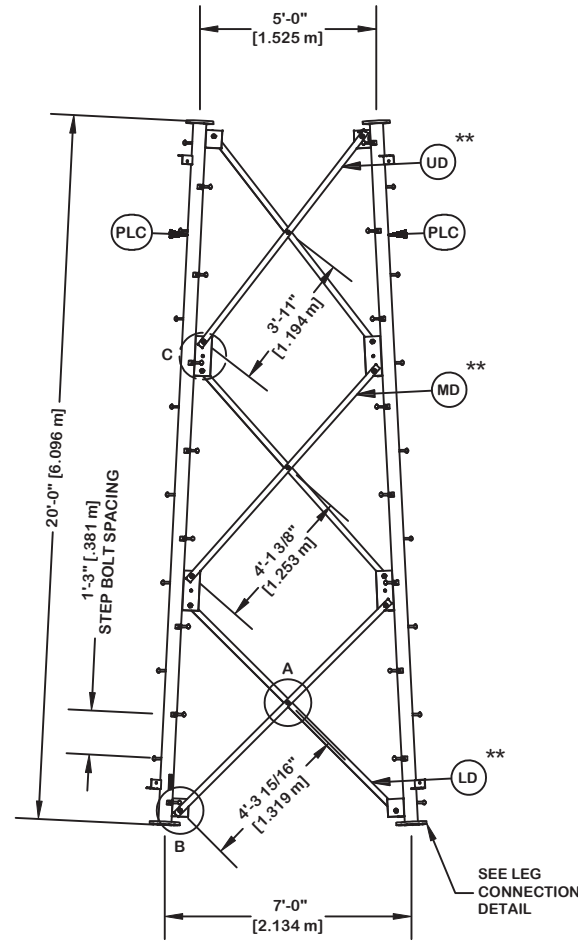

PARTS LIST					
ITEM	QTY	PART NO.	PART DESCRIPTION	UNIT WT.	NET WT.
PLC	3	226200	PIPE LEG SECTION 20'-0" (CLIMBING) 5" SCH. 40 V-SE	389.610	1168.830
STP	48	228189	STEP BOLT ASSY 5/8"-11 X 7" W/ LOCK WASHER HEAVY	1.100	52.800
LD	6	284730	V-7 LOWER CLIPPED ANGLE - 2" X 2" X 1/8" ANGLE (A5)	14.640	87.840
MB	9	227580	5/8"-11 X 2-1/4" A325T HOT DIPPED GALV. BOLT (FULL	0.640	5.760
AS	9	124838	MID-DIAGONAL SPACER 11/16" HOLE 3/8" THICK	0.450	4.050
MN	9	312501	5/8"-11 HOT DIPPED GALVANIZED NUT	0.120	1.080
ML	9	312123	5/8" GALVANIZED LOCKWASHER (53-22230)	0.020	0.180
SL	36	312153	3/4" GALVANIZED LOCKWASHER	0.030	1.080
SN	36	312502	3/4"-10 HOT DIPPED GALVANIZED NUT	0.190	6.840
SB	36	227579	3/4"-10 X 2-1/4" A-325T BOLT WITH FULL THREAD	0.420	15.120
MD	6	284729	V-7 MID ANGLE - 2" X 2" X 1/8" ANGLE (A572 GR. 50)	13.920	83.520
UD	6	284728	V-7 UPPER ANGLE - 2" X 2" X 1/8" ANGLE (A572 GR. 5	13.190	79.140
LCB	24	227668	3/4"-10 X 3-1/2" A-325T BOLT WITH FULL THREAD	0.540	12.960
LCF	24	312152	3/4" GALVANIZED FLAT WASHER (F436)	0.080	1.920
LCL	24	312153	3/4" GALVANIZED LOCKWASHER	0.030	0.720
LCN	24	312502	3/4"-10 HOT DIPPED GALVANIZED NUT	0.190	4.560
Total Wt				1526.40 lb [693.00 kg]	

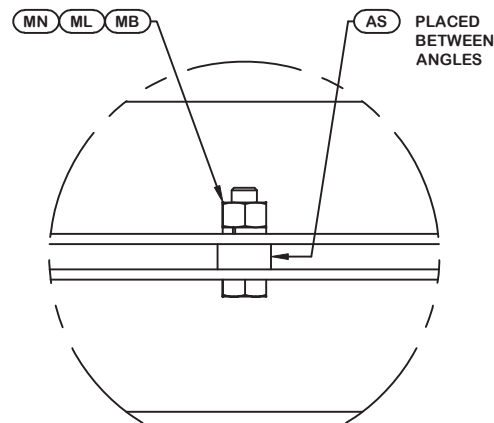

DETAIL A
ANGLE INTERSECTION CONNECTION

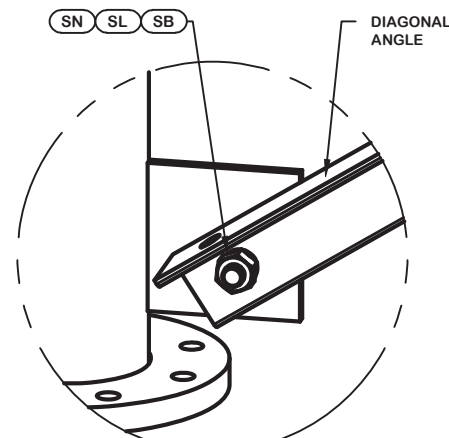

DETAIL B
END SIDE PLATE ANGLE CONNECTION

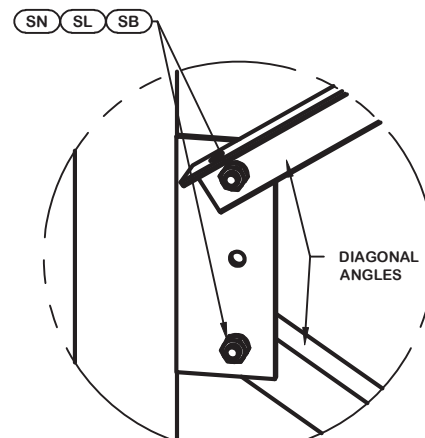

DETAIL C
MID SIDE PLATE ANGLE CONNECTION

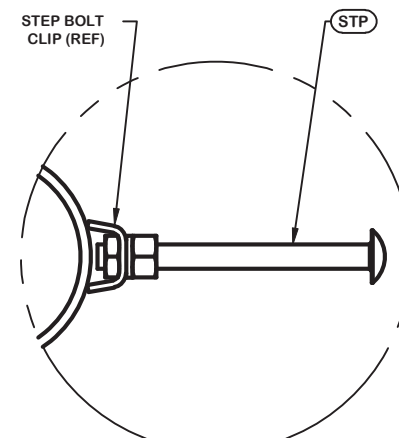

STEP BOLT INSTALLATION

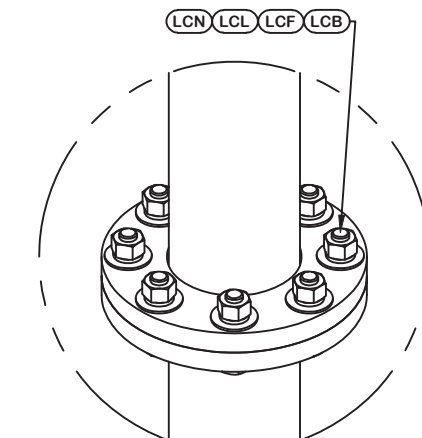

LEG TO LEG CONNECTION
(SIDE PLATES NOT SHOWN FOR CLARITY)



June 1, 2020

REV	DESCRIPTION OF REVISIONS	CPD	BY	DATE
REVISION HISTORY				

SITE
**CHATHAM LANDFILL, NC
MOTOROLA SOLUTIONS
U 35 X 350'**

COPYRIGHT 2013

PROPRIETARY NOTE:
THE DATA AND TECHNIQUES CONTAINED IN THIS DRAWING ARE PROPRIETARY INFORMATION OF VALMONT INDUSTRIES AND CONSIDERED A TRADE SECRET. ANY USE OR DISCLOSURE WITHOUT THE CONSENT OF VALMONT INDUSTRIES IS STRICTLY PROHIBITED.

DESCRIPTION
SECTION V-7.0 (280' - 300' ELEVATION)

STRUCTURE APPROVAL
MVC 5/28/2020

FOUNDATION APPROVAL

valmont STRUCTURES

1-877-467-4763 Plymouth, IN
1-800-547-2151 Salem, OR

ENG. FILE NO. **474445**

DWG. NO. **289290T**

ORIENT LEGS WITH P/N STAMP
TOWARD BOTTOM OF SECTION

ORIENT ANGLES WITH STAMPED
END TOWARD TOP OF SECTION

** DIAGONAL ANGLES MUST BE INSTALLED
WITH THE NON-BOLTED FACE UP,  THIS MAY BE ON THE OPPOSITE SIDE OF THE
SIDE PLATE THAN WHAT IS SHOWN IN THE DETAIL.

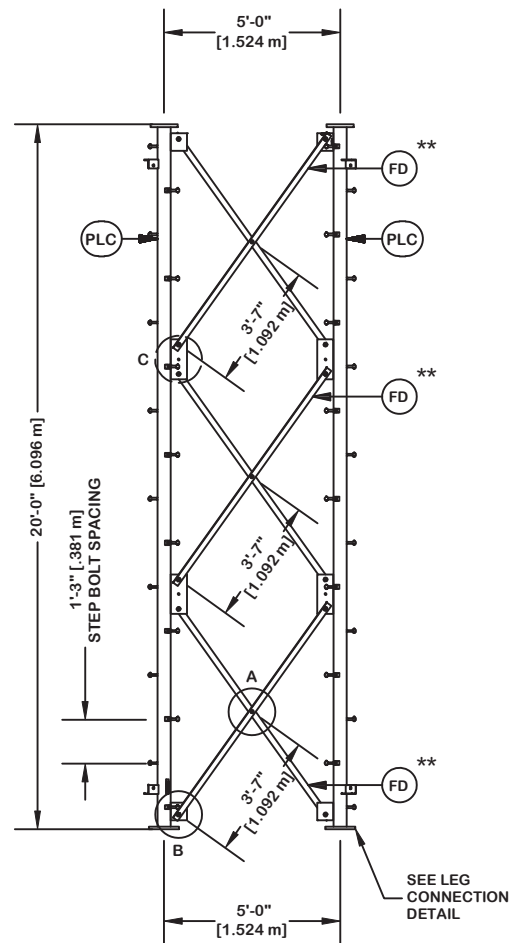

PARTS LIST					
ITEM	QTY	PART NO.	PART DESCRIPTION	UNIT WT.	NET WT.
PLC	3	226184	PIPE LEG SECTION 20'-0" (CLIMBING) 4" SCH. 40 V-SE	302.080	906.240
STP	48	228189	STEP BOLT ASSY 5/8"-11 X 7" W/ LOCK WASHER HEAVY	1.100	52.800
FD	18	285010	V-5 DIAGONAL ANGLE - 2" X 2" X 1/8" ANGLE (A572 GR)	13.070	235.260
ML	9	312123	5/8" GALVANIZED LOCKWASHER (53-22230)	0.020	0.180
AS	9	116467	RING FILL SPACER 1/4" THICK 1.049" DIA HOLE	0.250	2.250
MB	9	227580	5/8"-11 X 2-1/4" A325T HOT DIPPED GALV. BOLT (FULL	0.640	5.760
MN	9	312501	5/8"-11 HOT DIPPED GALVANIZED NUT	0.120	1.080
SL	36	312153	3/4" GALVANIZED LOCKWASHER	0.030	1.080
SN	36	312502	3/4"-10 HOT DIPPED GALVANIZED NUT	0.190	6.840
SB	36	227579	3/4"-10 X 2-1/4" A-325T BOLT WITH FULL THREAD	0.420	15.120
LCB	18	227668	3/4"-10 X 3-1/2" A-325T BOLT WITH FULL THREAD	0.540	9.720
LCF	18	312152	3/4" GALVANIZED FLAT WASHER (F436)	0.080	1.440
LCL	18	312153	3/4" GALVANIZED LOCKWASHER	0.030	0.540
LCN	18	312502	3/4"-10 HOT DIPPED GALVANIZED NUT	0.190	3.420

Total Wt 1241.73 lb [563.76 kg]

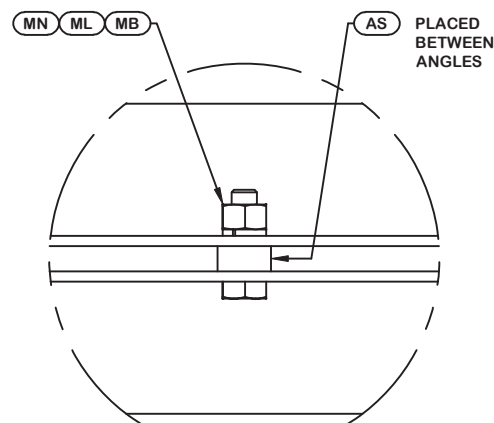

DETAIL A
ANGLE INTERSECTION CONNECTION

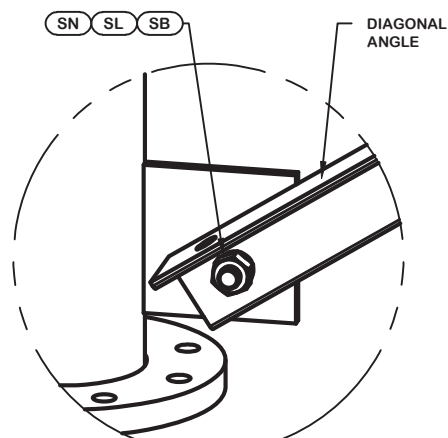

DETAIL B
END SIDE PLATE ANGLE CONNECTION

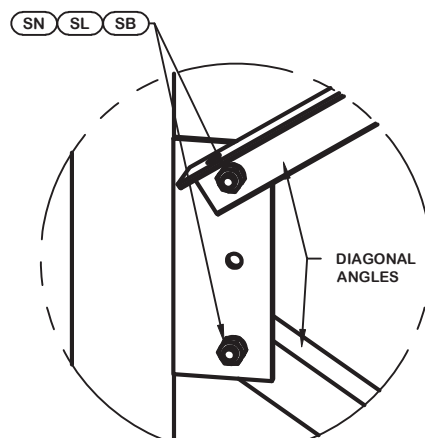

DETAIL C
MID SIDE PLATE ANGLE CONNECTION

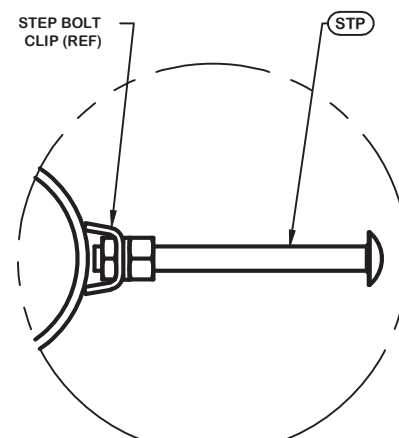

STEP BOLT INSTALLATION

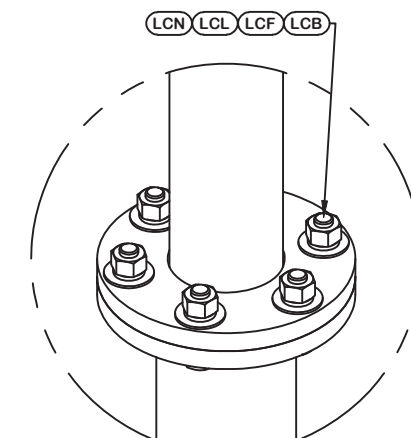

LEG TO LEG CONNECTION
(SIDE PLATES NOT SHOWN FOR CLARITY)



June 1, 2020

REV	DESCRIPTION OF REVISIONS	CPD	BY	DATE
REVISION HISTORY				

SITE	CHATHAM LANDFILL, NC MOTOROLA SOLUTIONS U 35 X 350'
COPYRIGHT 2013	
PROPRIETARY NOTE:	THE DATA AND TECHNIQUES CONTAINED IN THIS DRAWING ARE PROPRIETARY INFORMATION OF VALMONT INDUSTRIES AND CONSIDERED A TRADE SECRET. ANY USE OR DISCLOSURE WITHOUT THE CONSENT OF VALMONT INDUSTRIES IS STRICTLY PROHIBITED.

DESCRIPTION	SECTION V-5.0 (300' - 320' ELEVATION)
STRUCTURE APPROVAL	MVC 5/28/2020
FOUNDATION APPROVAL	

	
ENG. FILE NO.	474445
DWG. NO.	289290T

ORIENT LEGS WITH P/N STAMP
TOWARD BOTTOM OF SECTION

INSTALL ANGLES WITH STAMPED
END TOWARD TOP OF SECTION

** DIAGONAL ANGLES MUST BE INSTALLED
WITH THE NON-BOLTED FACE UP, 
THIS MAY BE ON THE OPPOSITE SIDE OF THE
SIDE PLATE THAN WHAT IS SHOWN IN THE DETAIL.

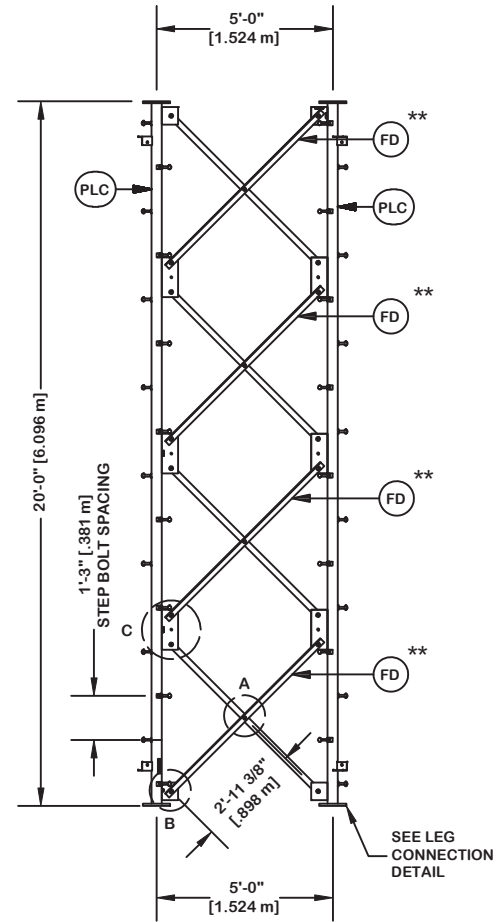

PARTS LIST					
ITEM	QTY	PART NO.	PART DESCRIPTION	UNIT WT.	NET WT.
PLC	3	226160	PIPE LEG SECTION 20'-0" (CLIMBING) 2 1/2" SCH. 40	194.380	583.140
STP	48	228189	STEP BOLT ASSY 5/8"-11 X 7" W/ LOCK WASHER HEAVY	1.100	52.800
FD	24	284980	V-5 DIAGONAL ANGLE - 2" x 2" x 1/8" ANGLE (A572 GR	10.820	259.680
ML	12	312123	5/8" GALVANIZED LOCKWASHER (53-22230)	0.020	0.240
AS	12	116467	RING FILL SPACER 1/4" THICK 1.049" DIA HOLE	0.250	3.000
MB	12	227580	5/8"-11 X 2-1/4" A325T HOT DIPPED GALV. BOLT (FULL	0.640	7.680
MN	12	312501	5/8"-11 HOT DIPPED GALVANIZED NUT	0.120	1.440
SL	48	312153	3/4" GALVANIZED LOCKWASHER	0.030	1.440
SN	48	312502	3/4"-10 HOT DIPPED GALVANIZED NUT	0.190	9.120
SB	48	227579	3/4"-10 X 2-1/4" A-325T BOLT WITH FULL THREAD	0.420	20.160
LCB	12	227668	3/4"-10 X 3-1/2" A-325T BOLT WITH FULL THREAD	0.540	6.480
LCF	12	312152	3/4" GALVANIZED FLAT WASHER (F436)	0.080	0.960
LCL	12	312153	3/4" GALVANIZED LOCKWASHER	0.030	0.360
LCN	12	312502	3/4"-10 HOT DIPPED GALVANIZED NUT	0.190	2.280

Total Wt 948.78 lb [430.75 kg]

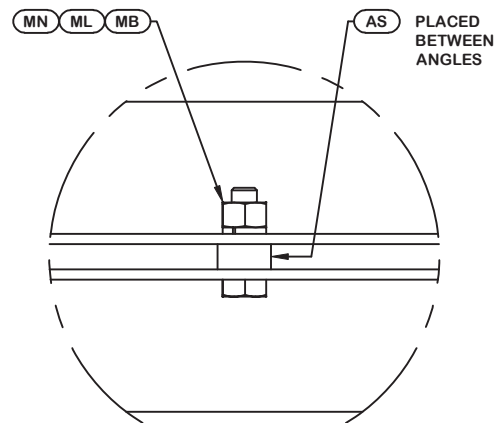

DETAIL A
ANGLE INTERSECTION CONNECTION

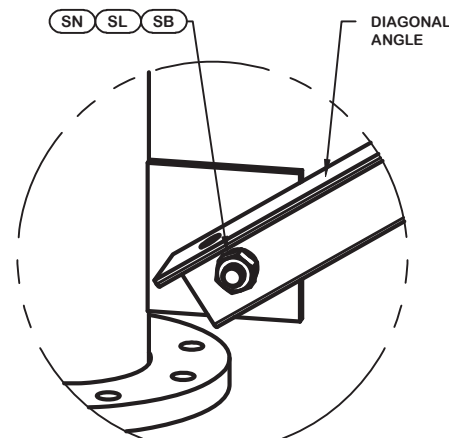

DETAIL B
END SIDE PLATE ANGLE CONNECTION

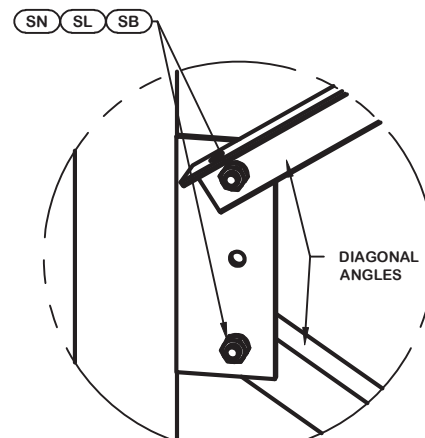

DETAIL C
MID SIDE PLATE ANGLE CONNECTION

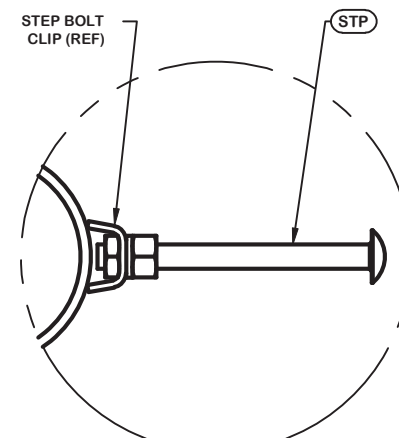

STEP BOLT INSTALLATION

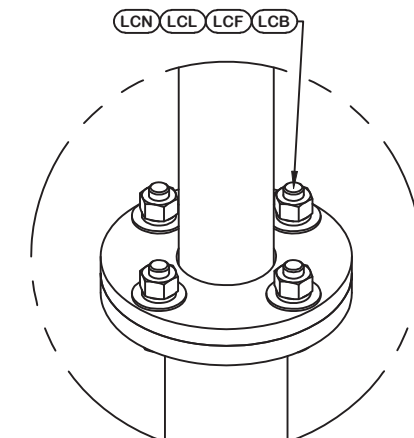

LEG TO LEG CONNECTION
(SIDE PLATES NOT SHOWN FOR CLARITY)



June 1, 2020

REV	DESCRIPTION OF REVISIONS	CPD	BY	DATE
REVISION HISTORY				

SITE	CHATHAM LANDFILL, NC MOTOROLA SOLUTIONS U 35 X 350'
COPYRIGHT 2013	
PROPRIETARY NOTE:	THE DATA AND TECHNIQUES CONTAINED IN THIS DRAWING ARE PROPRIETARY INFORMATION OF VALMONT INDUSTRIES AND CONSIDERED A TRADE SECRET. ANY USE OR DISCLOSURE WITHOUT THE CONSENT OF VALMONT INDUSTRIES IS STRICTLY PROHIBITED.

DESCRIPTION	SECTION V-5.0 (320' - 340' ELEVATION)
STRUCTURE APPROVAL	MVC 5/28/2020
FOUNDATION APPROVAL	

	
1-877-467-4763 Plymouth, IN	1-800-547-2151 Salem, OR
ENG. FILE NO.	474445
DWG. NO.	289290T

ORIENT LEGS WITH P/N STAMP
TOWARD BOTTOM OF SECTION

INSTALL ANGLES WITH STAMPED
END TOWARD TOP OF SECTION

** DIAGONAL ANGLES MUST BE INSTALLED
WITH THE NON-BOLTED FACE UP.
THIS MAY BE ON THE OPPOSITE SIDE OF THE
SIDE PLATE THAN WHAT IS SHOWN IN THE DETAIL.

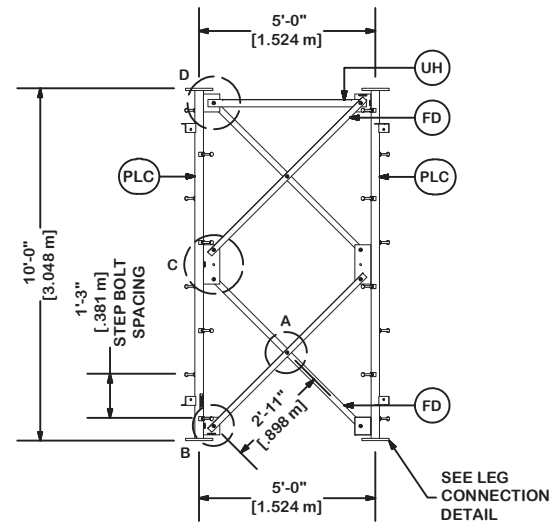

PARTS LIST					
ITEM	QTY	PART NO.	PART DESCRIPTION	UNIT WT.	NET WT.
PLC	3	226172	PIPE LEG SECTION 10'-0" (CLIMBING) 2 1/2" SCH. 40	108.330	324.990
STP	24	228189	STEP BOLT ASSY 5/8"-11 X 7" W/ LOCK WASHER HEAVY	1.100	26.400
FD	12	284980	V-5 DIAGONAL ANGLE - 2" x 2" x 1/8" ANGLE (A572 GR	10.820	129.840
ML	6	312123	5/8" GALVANIZED LOCKWASHER (53-22230)	0.020	0.120
AS	6	116467	RING FILL SPACER 1/4" THICK 1.049" DIA HOLE	0.250	1.500
MB	6	227580	5/8"-11 X 2-1/4" A325T HOT DIPPED GALV. BOLT (FULL	0.640	3.840
MN	6	312501	5/8"-11 HOT DIPPED GALVANIZED NUT	0.120	0.720
SL	24	312153	3/4" GALVANIZED LOCKWASHER	0.030	0.720
SN	24	312502	3/4"-10 HOT DIPPED GALVANIZED NUT	0.190	4.560
SB	24	227579	3/4"-10 X 2-1/4" A-325T BOLT WITH FULL THREAD	0.420	10.080
UH	3	285974	V-5 HORIZONTAL ANGLE (TYPE 1) - 3" x 3" x 1/4" ANG	21.500	64.500
LCB	12	227668	3/4"-10 X 3-1/2" A-325T BOLT WITH FULL THREAD	0.540	6.480
LCF	12	312152	3/4" GALVANIZED FLAT WASHER (F436)	0.080	0.960
LCL	12	312153	3/4" GALVANIZED LOCKWASHER	0.030	0.360
LCN	12	312502	3/4"-10 HOT DIPPED GALVANIZED NUT	0.190	2.280
Total Wt				577.35 lb [262.12 kg]	



June 1, 2020

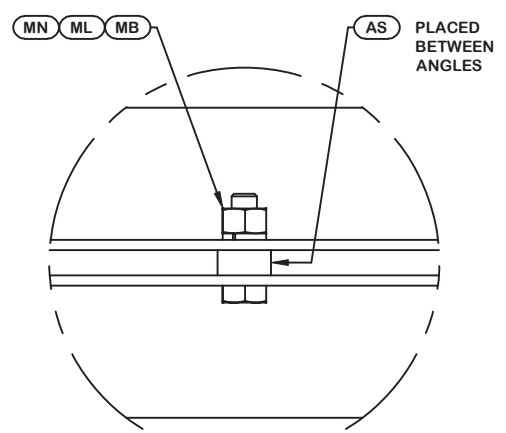

DETAIL A
ANGLE INTERSECTION CONNECTION

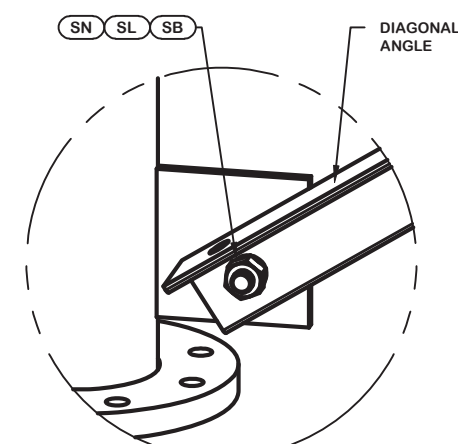

DETAIL B
END SIDE PLATE ANGLE CONNECTION

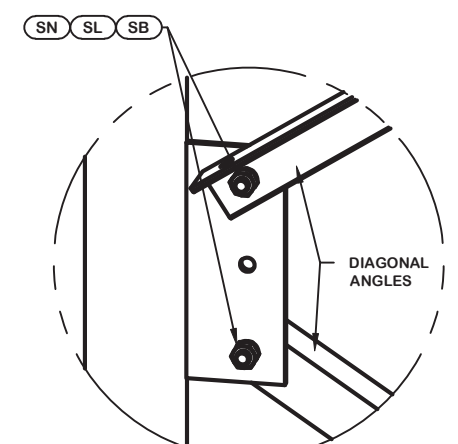

DETAIL C
MID SIDE PLATE ANGLE CONNECTION

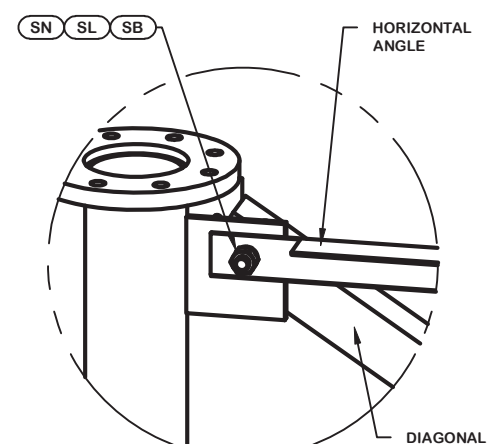

DETAIL D
UPPER HORIZONTAL ANGLE CONNECTION

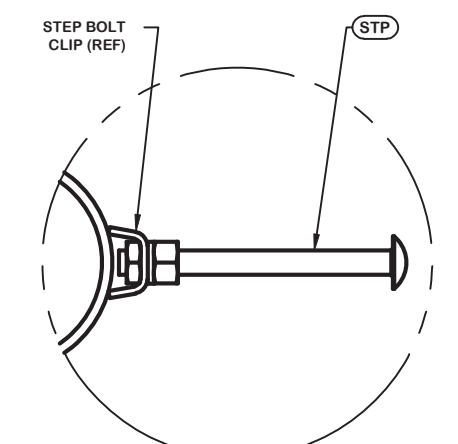

STEP BOLT INSTALLATION

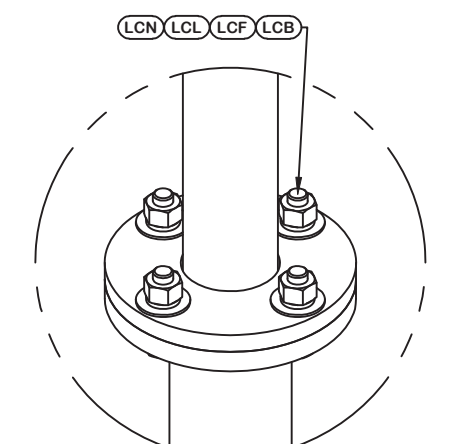

LEG TO LEG CONNECTION
(SIDE PLATES NOT SHOWN FOR CLARITY)

REV	DESCRIPTION OF REVISIONS	CPD	BY	DATE
REVISION HISTORY				

SITE
**CHATHAM LANDFILL, NC
MOTOROLA SOLUTIONS
U 35 X 350'**

COPYRIGHT 2013

PROPRIETARY NOTE:
THE DATA AND TECHNIQUES CONTAINED IN THIS DRAWING ARE PROPRIETARY INFORMATION OF VALMONT INDUSTRIES AND CONSIDERED A TRADE SECRET. ANY USE OR DISCLOSURE WITHOUT THE CONSENT OF VALMONT INDUSTRIES IS STRICTLY PROHIBITED.

DESCRIPTION
SECTION V-5.0 (340' - 350' ELEVATION)

STRUCTURE APPROVAL
MVC 5/28/2020

FOUNDATION APPROVAL

valmont

1-877-467-4763 Plymouth, IN
1-800-547-2151 Salem, OR

STRUCTURES

ENG. FILE NO. **474445**

DWG. NO. **289290T**

REBAR/ANCHOR STEEL TABLE				
ITEM	QTY	PART DESCRIPTION	UNIT WT.	NET WT.
1	36	1 1/4" DIA. x 80" LONG ANCHOR BOLT - 109881	27.88	1003.60
2	3	EMBEDMENT PLATE - 217971	30.11	90.33
APPROX TOTAL WT #				1093.93

NOTE:
FOUNDATION DESIGN BY OTHERS

FOUNDATION NOTES:

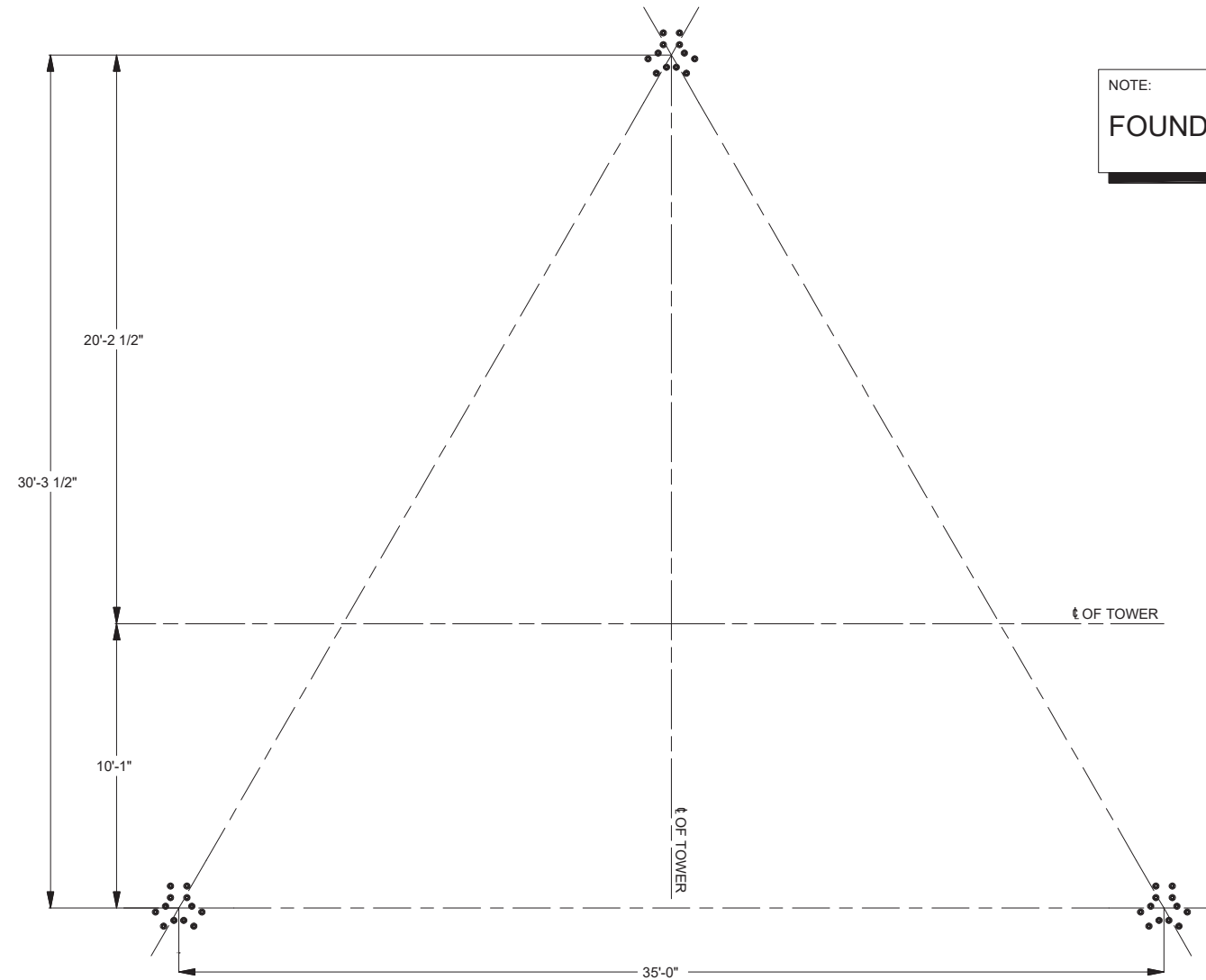

PACK NON-SHRINK STRUCTURAL GROUT UNDER FLANGE AFTER LEVELING TOWER
NON-SHRINK GROUT TO HAVE COMPRESSIVE STRENGTH OF 5000 PSI @28 DAYS

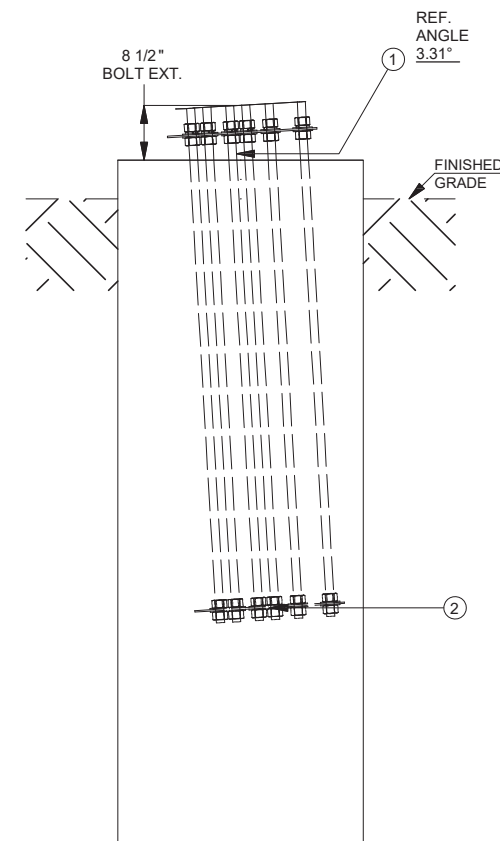

ATTENTION CONTRACTOR INSTALLING ANCHOR BOLT!
1 1/4" DIA. ANCHOR BOLTS REQUIRED.
INSTALL ALL ANCHOR BOLTS WITH LONGER THREADED ENDS EXPOSED
VERIFY THE PART NUMBER AND SIZES FOR ALL COMPONENTS ON THIS PAGE.
IF THERE ARE ANY DISCREPANCIES, PLEASE NOTIFY VALMONT/PIROD, INC
PRIOR TO INSTALLATION!

TEMPLATE INSTALLATION NOTES:

1. THE PROVIDED TEMPLATE ASSEMBLY MUST BE USED TO ENSURE ACCURATE ANCHOR BOLT LOCATION & INSTALLATION ANGLE (BASE LEG REFERENCE ANGLE 3.31°.)
2. USING THE TEMPLATE ASSEMBLY, EACH ANCHOR BOLT GROUP MUST BE LOCATED IN FOUNDATION AS SHOWN IN THE PLAN VIEW (+/- 3"). FAILURE TO USE THE FULLY ASSEMBLED ANCHOR BOLT TEMPLATE WILL CAUSE MISS-LOCATION OF ANCHOR BOLT GROUPS. INCORRECTLY LOCATED ANCHOR BOLT GROUPS WILL CAUSE DIFFICULTY DURING TOWER CONSTRUCTION. IN MORE SEVERE CASES, THIS CAN MAKE IT IMPOSSIBLE TO ERECT TOWER.
3. TEMPLATE ASSEMBLY MUST BE LEVEL +/- 1".
4. INSTALLED TEMPLATE CLEARANCE: **2" MIN - 4" MAX**
5. MUST USE TEMPLATE ASSEMBLY# 213379



June 1, 2020

<table border="1"> <thead> <tr> <th>REV</th> <th>DESCRIPTION OF REVISIONS</th> <th>CPD</th> <th>BY</th> <th>DATE</th> </tr> </thead> <tbody> <tr> <td colspan="5">REVISION HISTORY</td> </tr> </tbody> </table>					REV	DESCRIPTION OF REVISIONS	CPD	BY	DATE	REVISION HISTORY					SITE CHATHAM LANDFILL, NC MOTOROLA SOLUTIONS U 35 X 350' COPYRIGHT 2013		DESCRIPTION Additional Foundation Information		 1-877-467-4763 Plymouth, IN 1-800-547-2151 Salem, OR	
					REV	DESCRIPTION OF REVISIONS	CPD	BY	DATE											
REVISION HISTORY																				
STRUCTURE APPROVAL MVC 5/28/2020		FOUNDATION APPROVAL M_S 5/28/2020		ENG. FILE NO. 474445																
				DWG. NO. 289290F																