



Detailed Specifications & Standard Drawings



**Chatham County Public Utilities & Water Division
P.O. Box 910; 964 East Street, 2nd Floor/Suite 205
Pittsboro, NC 27312**

**Telephone: (919) 852-8270 Fax: (919) 852-8282
www.chathamnc.org**

*Adopted: August 2, 2004
Revisions Adopted: May 16, 2006
Revisions Adopted: July 1, 2015*

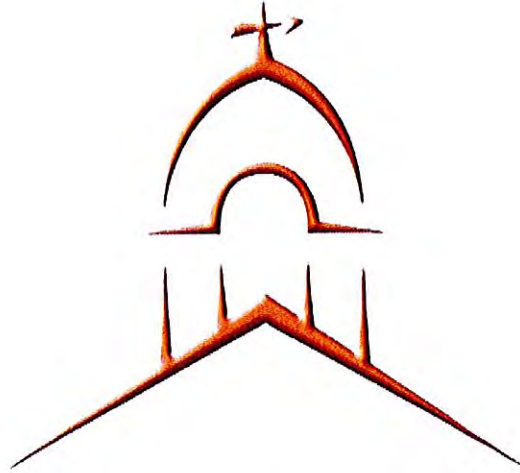

CHATHAM COUNTY
NORTH CAROLINA

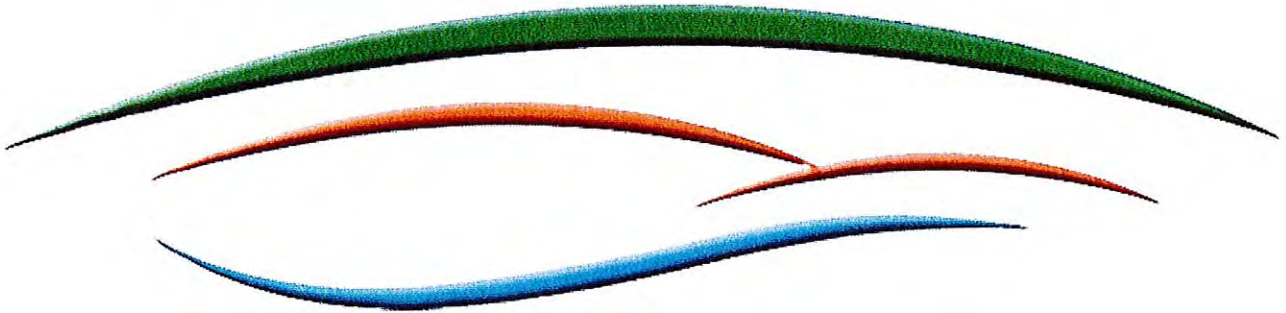

GENERAL PROCEDURES

CHATHAM COUNTY PUBLIC UTILITIES & WATER DIVISION

GENERAL PROCEDURES

GENERAL

The purpose of this manual is to provide for the orderly development of water systems to meet the needs of residents and businesses of Chatham County, North Carolina. The guidelines have been developed with the intent to accommodate the individuality of each project while maintaining high standards and an orderly procedure.

The policies and procedures set forth by this manual are applicable to all utility contractors, engineers, developers and others installing water connecting to the Chatham County Water System. These high standards and the professional processes are necessary to control the quality and overall integrity of water extensions of which the County assumes operational and maintenance responsibility and to ensure the water system will provide low maintenance and reliable service to the our customers.

CHATHAM COUNTY CONTACT INFORMATION

County Manager

Renee Paschal

919-542-8200

renee.paschal@chathamnc.org

Assistant County Manager/Public Works Director

Dan LaMontagne, PE

919-545-8531

dan.lamontagne@chathamnc.org

Public Utilities Director

Larry Bridges

919-542-8270

larry.bridges@chathamnc.org

1. DEVELOPERS' PROCEDURE

1.1. Activity Sequence: The following is the general sequence of activities to be followed by a Developer wishing to construct and have accepted for service any water extension to the County's System that is to serve any single or multi-unit development.

1.1.1. Developer's Request for Water Availability

1.1.2. County Response - Letter of Availability

1.1.3. Construction Plan Submittal

1.1.4. County Review and Approval of Construction Plan

1.1.5. Construction Permitting

1.1.6. Pre-Construction Conference

1.1.7. Construction/Inspection

1.1.8. Service Authorization/County Acceptance.

1.1.9. ***All fees shall be paid to the County in accordance with published Policies and Rates.***

1.2. Permits and Approvals: The Developer, or their assigned agent (such as the Design Engineer), shall be responsible for obtaining all applicable permits and approvals prior to commencement of water main construction. The following shall outline permits that are generally required for water main construction:

1.2.1. North Carolina Department of Environmental Quality (NCDEQ) – Division of Energy, Mineral and Land Resources: Sedimentation and Erosion Control. This permit shall be applicable if the disturbed area is greater than one acre.

1.2.2. NCDEQ – Division of Water Resources: Public Water Supply Authorization to Construct and Final Approval. This permit shall be applicable for any extension or expansion of the Chatham County Water Systems.

1.2.3. NCDEQ - Division of Water Resources: 404 Certification.

1.2.4. North Carolina Department of Transportation (NCDOT): Encroachment Agreement. This permit shall be applicable when construction is partly or entirely within the NCDOT Rights of Way.

1.2.5. United States Army Corps of Engineers (USACOE): 401 Certification and Pre-Construction Notification. This permit shall be applicable when the project impacts jurisdictional wetlands exceeding 1/3 of an acre and in most cases will be a Nationwide 12 Permit for utility projects.

1.2.6. Chatham County Public Works: Approval of Plans and Specifications. This approval shall apply to all extensions or expansions of the Chatham County Water Systems.

1.2.7. Fire Flow Report Requirements:

If a hydrant is proposed on a project, a fire flow analysis report is required to be approved by Chatham County. The fire flow analysis shall be in accordance with NFPA 291. The Design Engineer shall be responsible for contacting the county to determine the water system characteristics in the vicinity of the project and to obtain a Fire Flow Test Application. The

county will provide fire flow information in the vicinity of the proposed development. The Design Engineer shall submit information on the required fire flow and calculations to confirm the required fire flow is available. The fire flow analysis shall include the following:

1.2.7.1. Cover sheet with project name, property identification number and PE seal and signature

1.2.7.2. Summary Report should include the following:

1.2.7.2.1. Location of pressure hydrant in relation to the site.

1.2.7.2.2. Statement of required fire flow for the project. Briefly describe the project and indicate current zoning of the parcel.

1.2.7.2.3. Statement of the following: "The (name of project) project with (required fire flow) gpm fire flow, (required peak domestic demand) gpm peak domestic flow and (sprinkler flow demand from sprinkler designer) gpm sprinkler flow provides (lowest residual pressure in system) psi residual flow at the critical node (lowest residual pressure system node). This (meets)/ (does not meet) the Chatham County fire flow requirements.

1.2.7.2.4. Schematic drawing with pipe system layout referencing nodes and pipes. Map (to scale) of location of test hydrant (pressure) and the location of the site clearly indicated.

1.2.7.2.5. List original water system characteristics as provided by the county noting date, location, flow hydrant, pressure hydrant and Q20 flow available.

1.2.7.2.6. Pipe and node report indicating pipe sizes, lengths, frictions factor, minor losses and appropriate elevations and demands. Provide all references for minor loss factors and if a range is given state the value you are using. (Use C=120 for new pipes and C=110 for existing pipes)

1.2.7.2.7. Static condition indicating only new domestic demand. (Provide all references and calculations for domestic peak demands)

1.2.7.2.8. Separate fire flow models from each hydrant to indicate each hydrant is capable of providing the fire flow demand while concurrently providing peak domestic and fire protection system demand.

1.2.7.3. *If the fire flow analysis does not meet the minimum Chatham County requirements, then the consultant shall contact Chatham County for further instruction, which may include additional offsite/onsite improvements.*

1.2.7.4. NOTE: At the successful completion of the waterline testing phase Chatham County may elect to flow test some of the hydrants to obtain data to compare against the fire flow analysis. If the flow data is inconsistent with the analysis, the design Developer/Engineer will be contacted to remedy the situation.

1.2.8. Agreement to Transfer Ownership of the water main extension/expansion to the County. This agreement shall be in place for all projects to be placed under the control and operation of Chatham County Water Systems.

1.3. Fees: All projects that will be owned and operated by Chatham County shall be subject to review prior to construction and operation. As part of the review process the Project Design

Engineer, Developer or Contractor shall be responsible for Chatham County's prevailing fees and rates for project review.

2. ENGINEERS' PROCEDURE

2.1. Responsibilities of the Design Engineer:

2.1.1. The Design Engineer shall provide the following to Chatham County Department of Public Works:

2.1.1.1. Three (3) sets of Final Plans and Specifications for initial review by the OWNER prior to submission to the regulatory agencies. The OWNER will review and comment on the Plans.

2.1.1.2. All design calculations relating to size of mains, pumps, control valves and storage facility.

2.1.1.3. Preliminary designation of pipe material and size for Chatham County's approval.

2.1.1.4. Two (2) sets of Final Plans and Specifications that the Design Engineer has addressed any concerns of the OWNER for approval prior to submission to the regulatory agencies. In addressing comments through a revision of the Plans and/or Specifications, the Design Engineer will provide the OWNER with the original Plans and Specifications that the OWNER marked up and returned to the Design Engineer.

2.1.1.5. Two sets of Final Plans and Specifications five (5) business days prior to the pre-construction conference.

2.1.1.6. Copies of all permits and approvals five (5) business days prior to the pre-construction conference.

2.1.2. The Design Engineer Shall:

2.1.2.1. Invite the OWNER's representative to attend the pre-construction conference providing said representative with minutes or record of the pre-construction conference.

2.1.2.2. Provide a minimum of three sets of construction submittals or shop drawings for OWNER's review and approval. These submittal data must be consistent with the minimum standards for materials as established in these specifications. Construction submittals are to be submitted to the OWNER ten (10) business days prior to the pre-construction conference so that they may be reviewed prior to said conference.

2.1.2.3. Provide documentation of any easements relevant to the project. If it is intended that Chatham County Water Systems become the owner of this extension, all such easements must be conveyed to Chatham County.

2.1.2.4. Designate all sites or parcels of land that contain pumps, meter vaults, control valves or storage facilities to be conveyed by deed to Chatham County.

2.1.2.5. Perform inspection of the water main extension/expansion and shall supply to Chatham County Public Works a record of all project inspection in the form of Inspection Reports and record of all water main testing (pressure test and sterilizations). The scope and level of this inspection shall be prescribed in advance by Chatham County Public Works.

2.1.2.6. Notify Chatham County Public Works at least 48 hours in advance of and water main testing so that Chatham County may Witness all test.

2.1.2.7. Upon completion of the project and prior to the Contractors de-mobilization, schedule and perform a joint Final Inspection and reach agreement among all of the parties involved to approve the project as constructed.

2.1.2.8. Provide Chatham County Public Works with Record Drawings, which accurately reflect the location of the water system extensions/expansion. Record Drawings shall be provided including one original mylar set and one Compact Disc with drawings in electronic format compatible with AutoCAD.

2.2. Easements: Water main easements shall be a minimum of 20 feet in width. Easements may need to be wider than 20 feet depending upon the size of the main and the equipment necessary to perform maintenance and repairs. All water main easements that become part of the Chatham County Water Systems shall be properly conveyed to Chatham County prior to assumption of ownership. All easements are subject to review by Chatham County and the County's legal staff prior to recordation of the final plat or documents. See easement detail in specifications.

2.3. Construction Plan Requirements:

2.3.1. All plans shall be prepared by a licensed engineer and shall have his/her seal and signature certification on the plans. A note is to be included on the construction plans that all construction is to be in accordance with all Chatham County and NCDEQ requirements, standards and specifications.

2.3.2. The plan of the proposed development shall be clearly and legibly drawn to a scale no smaller than one (1) inch equal to fifty (50) feet or as deemed appropriate by Chatham County and shall be no larger than 24" x 36". All written notes or numbers will be 1/8" minimum.

2.3.3. If the plan requires more than one sheet, a key showing locations of the several sections shall be provided and match lines shall be drawn on each sheet.

2.3.4. Proposed name of project, lot, block numbers and tax map number.

2.3.5. North arrow, graphic scale, written scale and date, including the month, day, and year that the original drawing was completed and the month, day, and year for each revision of the original drawing. Title block with engineer's name, address, and telephone number. Name of owner of record of development with address and telephone number.

2.3.6. A vicinity or location map, for the purpose of locating the property being developed, drawn at a scale of no less than one (1) inch equals two thousand (2,000) feet and showing the relation of the project to adjoining properties, streets, roads, municipal boundaries, and subdivisions.

2.3.7. Total tract boundaries of the property being developed and total acreage of property being developed. Name, registration number, and seal of registered surveyor. Reference any information provided by others.

- 2.3.8. Show all existing streets with names/numbers, including streets of record (recorded but not constructed), on or abutting the project, including right-of-way widths.
- 2.3.9. Show location and names of streams, lakes, swamps, and wetlands and any other water courses. Areas subject to flooding shall be designated. Indicate MSL elevations for all above areas.
- 2.3.10. Specify whether proposed waterlines are to be placed in existing easements or right-of-ways. Show locations of poles, towers, and other utilities within the existing right-of-ways.
- 2.3.11. Show size, location and type materials of existing sewers and water mains. Indicate drains, culverts, or other underground facilities within the street or within the right-of-way of streets or roads adjoining the tract which may interfere with waterlines proposed.
- 2.3.12. Layout of all lots with lot numbers including phase lines and proposed waterlines. Layout of streets, roads, alleys, public crosswalks, including widths. Road names shall be shown. Total number of lots and the use designation of lots.
- 2.3.13. All other proposed utility easements and right-of-ways including power, gas, telephone, TV cable, and storm drainage systems outside of road right-of-ways. Designate land that is to be conveyed to the County.
- 2.3.14. Layout of fire protection system, including location/type backflow preventers.
- 2.3.15. Utility easements for gas, electric lines, telephone, CATV proposed to cross or share proposed waterlines shall be designated.
- 2.3.16. The location and elevation of a bench mark. All elevations are to be referenced to a USGS bench mark or a TBM established from a USGS monument.
- 2.3.17. Waterline designs shall denote sizes and all appurtenances, valves, backflow prevention devices, tees, and bends, and where necessary, detailed blow-ups of interconnections shall be shown. Location of fire hydrants and/or any special appurtenances provided in the water system design shall be shown. Applications requiring backflow prevention devices shall be in accordance with the County's Backflow Prevention Requirements.
- 2.3.18. Any other information considered by either the developer or the OWNER to be pertinent to the review of the plan.
- 2.3.19. Water transmission and distribution mains shall be designed for installation within an existing or proposed public right-of-way. Chatham County may at its discretion grant specific exceptions. The granting of an exception may be contingent upon the developers' compliance with additional easement, material, and design requirements.

2.3.20. Water systems shall be designed so as to provide fire flow protection as outlined in the Chatham County's Detailed Specifications and the requirements of NCDEQ.

2.3.21. Easements must be assigned from grantee to Chatham County.

3. CONSTRUCTION PROCEDURE

3.1. Pre-Construction Conference: The purpose of the conference is to outline coordination with the Chatham County's operations personnel, testing, inspection procedures, and project administrative procedures necessary to place the water system into operation, and dedication/final acceptance requirements.

At such time that the County has approved all construction plans/documents, all necessary permits and easements have been obtained and all administrative and construction related fees have been paid, a pre-construction conference can be scheduled by the County upon the following:

3.1.1. The consulting engineer shall be responsible for initiating coordination of the pre-construction conference with the Public Works Department by submitting the following: Two sets of plans, water construction permits, developer project fees, encroachment permits, and shop drawings of all materials.

3.1.2. Pre-construction meeting requests received by the close of business on Monday will be scheduled for the following Monday.

3.1.3. The engineer and contractor are required to attend. Others who may attend are the developer, North Carolina Department of Transportation (NCDOT), NCDEQ and any other party deemed pertinent to the project.

3.1.4. No construction shall commence on any water utilities until a preconstruction conference is conducted and notice to proceed is issued by the Chatham County.

3.2. Responsibilities of the Contractor: The Contractor shall be responsible for the installation of the approved and permitted water systems. Water improvements shall be constructed in accordance with all applicable standards and specifications established by the NCDEQ and Chatham County. Nonconformance with established construction methods shall be cause to reject all construction.

3.2.1. Water Main Location: All water mains shall be located not less than a theoretical 1 to 1 from the edge of pavement or road. All water mains shall a minimum of three (3) feet of cover and a maximum of five (5) feet unless specifically authorized by the County. In the instance of new subdivision roads water mains shall not be installed until final grading of the roads and road shoulders have been completed. No water mains shall extend longitudinally under any paved or impervious surface, e.g., cul-de-sacs, turnouts. Final location of all water mains shall be reviewed and approved by Chatham County.

3.2.2. Services: The Contractor shall install all services as indicated in the specifications and where indicated by Chatham County. The meter at each service shall be furnished and installed by Chatham County.

3.2.3. Record Drawings and Specifications at the Job Site: The Contractor shall maintain, in readable condition at the job site, one complete set of working drawings and specifications for his work, including all shop drawings. Such drawings and specifications shall be available for use by the OWNER or his representative at all times. This set shall be marked or noted acceptable to the OWNER or his representative, in order to reflect record, or "as-built" conditions. The changes indicating such conditions shall be kept current at all times. "As-built" drawings shall be furnished to the OWNER at the completion of the project. The OWNER shall not accept the water main until such time that the "As-Builts" have been furnished and approved.

The "As-Built" drawings shall include but not be limited to distances of the water mains from the centerline of pavement; these dimensions shall be recorded at a minimum of every 200 linear feet. "As-Builts" shall also include distances from at least three reference points for main line valves (e.g., power poles, intersections, drainage structures, edge of pavement, property comers). Fittings shall also be included in the "As-Builts" and shall be located to at least two reference points.

3.2.4. Testing: The OWNER's and/or Engineer's representative shall be notified and shall have the option to be present at all pressure tests, during disinfection and at all bacteriological tests. If CONTRACTOR complete the tests without the OWNER's and/or Engineer's representative present after confirmation that they are to be present, the tests shall be repeated at CONTRACTOR'S cost.

3.2.5. Project Acceptance: The project acceptance shall be the date of the substantial completion. Substantial completion shall be defined as the date at which the Project is able to be placed into service (i.e. customers begin using water in each phase). This shall not occur prior to the date the OWNER receives satisfactory pressure and bacteriological test results on all lines and all punchlist items have been addressed to the satisfaction of the OWNER.

3.2.6. Project Warranty: A one year warranty period shall begin on the date of the Project Acceptance.

3.3. Construction Inspection: Routine, unscheduled inspection of on-going projects will be made periodically during construction by a County inspector. County inspectors will perform periodic checks during construction to ensure that the contractor is complying fully with the permitted project design, specifications, and policies and procedures of the County. Any deviation or revision to the approved engineering plans must be brought to the attention of the County's Inspector. Any deviations considered major by the County Inspector must then be submitted in writing with a revised plan to the Water Utility Department for approval. No deviations or revisions shall be initiated by the contractor until the County has approved the change(s) in writing. At the option of the County, full time inspection by the County's inspector

or the Engineer's, or the Design Engineer's inspector may be required. The developer will be responsible for any related increased costs connected with full time inspection by the County's or Engineer's Inspectors.

3.3.1. Stop Work Order: Failure to adhere to the approved plans and/or specifications established for the construction of a project or adherence to applicable requirements of the County may warrant issuance of a Stop Work Order. Copies of the Stop Work Order will be sent to the Developer, Design Engineer, and Contractor. Approval to restart construction shall be issued once all noted discrepancies have been corrected or procedures to make such corrections have been approved. Any construction performed by a contractor while under Stop Work Order will be considered unacceptable by the County.

3.3.2. Specific System Minimum Requirements

3.3.2.1. General: The Design Engineer shall provide a weekly inspection report(s) to the County's assigned inspector on each individual active project. For purposes of this requirement, a project shall be considered active for the period between the pre-construction meeting and final acceptance for O & M by the County.

3.3.2.2. Currently there is no prescribed format for these weekly reports. However as a minimum the reports must include: what was installed during the period, what installations were witnessed/not witnessed by the Design Engineer, or his/her inspector, a general indication of the quality of the work, installation conditions, the name of the inspector, the contractor and contractor's foreman. The weekly report must be signed by the Design Engineer of Record.

3.3.2.3. Pre-Construction: Shop drawings of project materials and components approved by the Design Engineer are to be provided to the County's Water Utility Department prior to the pre-construction conference. At the pre-construction meeting, the shop drawings shall be generally reviewed for consistency with County standards and specifications.

3.3.2.4. Following the pre-construction meeting but prior to start of construction, the County's inspector shall field inspect all materials and components on the project site. For all materials not initially on-site, the contractor shall provide 24-hour notice to the County's inspector prior to subsequent deliveries of materials so that they may also be inspected. The County's inspector may require that any materials installed prior to material inspection be uncovered and/or replaced. Approval of materials by the County's inspector shall not negate the contractor's or materials suppliers' guarantee of quality materials and workmanship in conformance with NCDEQ and Chatham County Water Systems standards.

3.3.2.5. Testing Lines: Developers shall perform pressure testing to ensure the integrity of their installed waterlines. The testing shall be coordinated with the County's project inspector. No official testing shall occur without the inspector's approval.

Only testing which occurs after all other utilities have been installed and site conditions are approved by the County's inspector will be acceptable to the County.

3.3.3. Final Inspection: A final County inspection will be conducted simultaneously with the NCDEQ inspection. The project engineer is responsible for coordinating the inspection schedule with the County. Prior to the inspection, two (2) sets of as-built construction plans shall be provided to the County's inspector at least ten (10) days prior to the scheduled final inspection. All pressure testing shall be completed prior to the final inspection. All satisfactory pressure test reports shall be presented to the County's Inspector at the final inspection. The final inspection requires the attendance of the Design Engineer and Contractor. The County inspector will make a punch list of any items to be corrected or will state that the project has been constructed substantially in accordance to the permitted plans and specifications.

3.3.4. Follow-Up Inspection: A follow-up inspection may be requested by the Design Engineer once all punch list items noted during the final inspection have been corrected. Should the follow up inspection prove that all punch list items have been satisfactorily completed, final construction approval can be issued by the County's inspector.

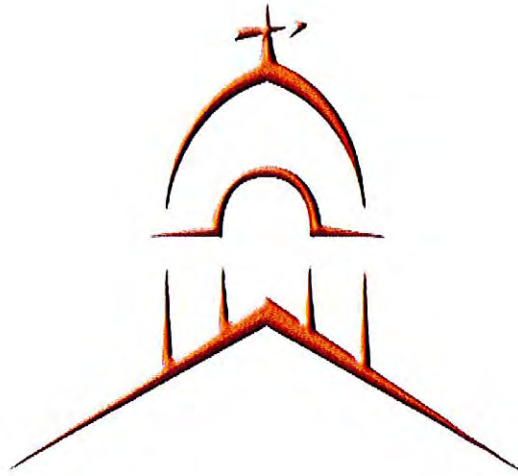

CHATHAM COUNTY
NORTH CAROLINA

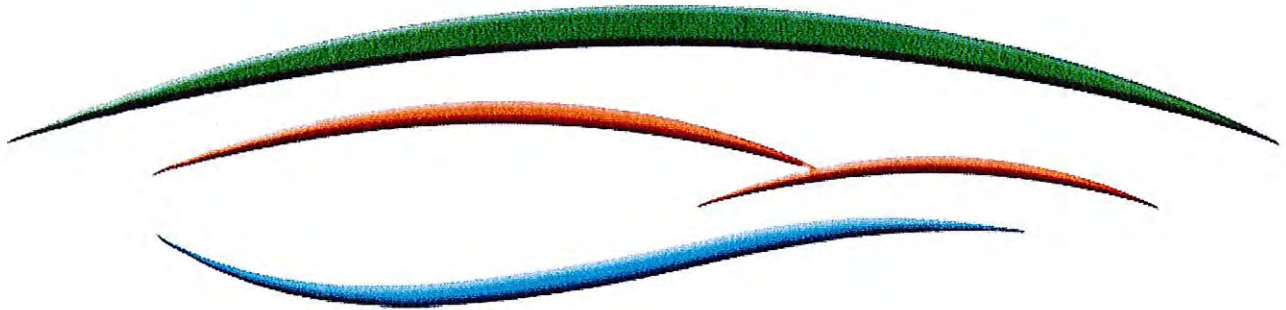

**GENERAL PROVISIONS AND
SPECIAL PROVISIONS**

CHATHAM COUNTY PUBLIC UTILITIES & WATER DIVISION

GENERAL PROVISIONS AND SPECIAL PROVISIONS

1. GENERAL PROVISIONS

1.1. Scope

- 1.1.1. The Contractor shall furnish and install all types of pipe, valves, fittings, appurtenances, and other incidentals required for the construction of a complete water system as shown on the detailed drawings and as specified herein. This work also includes all sediment and erosion control measures, testing and disinfection, clean-up, restoration of site, and other measures to achieve a complete and operational system for the County of Chatham's utilization.
- 1.1.2. Unless otherwise noted, the materials and associated manufacturers listed below are acceptable to the Owner for use in water distribution systems. Should the Contractor desire to use other materials not listed in these specifications, written permission must be obtained from the Chatham County Utilities Department or their assignees. The materials, models, model numbers, and/or trade names listed in these specifications shall serve as the minimum standard; however, Chatham County Utilities Department or their assignees shall review and approve all products for the project prior to construction.
- 1.1.3. All materials shall be free from defects impairing strength and durability and be of the best commercial quality for the purposes specified. It shall have structural properties sufficient to safely sustain or withstand strains and stresses to which it is normally subjected and be true to detail.

1.2. Shop Drawings and Submittals:

- 1.2.1. The Contractor shall submit to the Design Engineer copies of all submittal data for review and/or approval. The Design Engineer will review the submittals and will mark said submittals: "Approved"; "Approved As Noted"; "Revise and Resubmit", or; "Disapproved". The submittals will then be submitted to Chatham County Utilities Department for cursory review.
- 1.2.2. Submittals shall include at a minimum: (1) the manufacturer's name, (2) type of material, (3) ASTM, ANSI, AWWA or other quality standard and (4) pressure class. If the materials do not meet the quality standards specified, the submittals will be rejected and other materials submitted as specified. The Contractor must obtain approval of all pipe materials prior to commencing construction.
- 1.2.3. The Contractor shall submit to the Design Engineer copies of a certificate of inspection from the pipe manufacturer that the pipe supplied has been inspected at the plant and meets the requirements of these specifications and applicable AWWA and ANSI testing

requirements. The Engineer of Record will provide copies of the tests to Chatham County Utilities Department.

1.3. Delivery, Storage, And Handling:

- 1.3.1. Materials shall be delivered, handled, and maintained in a manner to avoid damage. Materials shall be stored in an open area on high, well-drained land not subject to flooding, mud or other means of contamination. PVC piping; rubber gaskets; jointing materials, and; any materials that are susceptible to exposure the elements and/or ultraviolet (UV) rays that are not to be installed immediately but are to be stored for more than 30 days shall be stored in a dry location and protected from the Sun.
- 1.3.2. Handle pipe, fitting, valves, hydrants, pumps, and appurtenances in a manner to ensure delivery to the trench or point of installation in a sound, undamaged condition. Take special care to avoid injury to coatings and linings on pipe and fittings; make satisfactory repairs, in accordance with the manufacturers' recommendations, if coating or linings are damaged, carry, do not drag pipe, fittings, valves, hydrants, and appurtenances to the trench.

2. SPECIAL PROVISIONS

2.1. Purpose of Specifications:

- 2.1.1. The purpose of these specifications is to provide a standard guideline for the design and construction of water main expansions that will be accepted for the public water systems owned and operated by Chatham County.
- 2.1.2. The materials, design and construction standards contained in these specifications are established as minimum standards. All acceptable materials and appurtenances are listed by name. In the instances that brand names are used, it is generally intended that a certain standard of quality be established, and not done to limit or restrict the use or purchase to any particular brand name, with very few exceptions. Chatham County however must approve all deviations from these specifications.
- 2.1.3. Although these detailed specifications, their existence in no way relieves the Professional Engineer designing the project of his/her responsibility to correctly adapt these specifications to actual project conditions.
- 2.1.4. All construction will be in compliance with all federal, state and local laws.

2.2. Terminology:

- 2.2.1. Interpretation of Certain Terms or Words: Except as specifically defined herein, all words used in these detailed specifications have their customary dictionary definitions. For the purposes of these detailed specifications, certain words or terms used herein are defined as follows:

- 2.2.1.1. Words used in the present tense include the future tense. Words used in the singular include the plural and words used in the plural include the singular.
 - 2.2.1.2. The word "**shall**" is always mandatory.
 - 2.2.1.3. The word "**may**" is permissive.
 - 2.2.1.4. The word "**lot**" includes the word "**plat**" or "**parcel**".
 - 2.2.1.5. The word "**person**" includes a firm, association, organization, partnership, trust company, group or corporation as well as an individual.
- 2.2.2. Definitions: Whenever used in these detailed specifications, the following terms shall have the meanings as set forth here.
- 2.2.2.1. Chatham County/Owner/County: Whenever these terms are used, they refer to Chatham County.
 - 2.2.2.2. Owners Representative: An individual formally authorized by the project's Owner to take actions pertaining to the project on the Owner's behalf.
 - 2.2.2.3. Director of Public Works or his assigns: This term refers to Chatham County's Director of Public Works or his duly authorized representatives.
 - 2.2.2.4. Engineer: This term refers to the Consulting Engineer in the employ of Chatham County, an assistant or other representative duly authorized by said Engineer.
 - 2.2.2.5. Design Engineer: The Engineer in responsible charge of the project design and construction. This person may be in the employ of the Owner or Developer.
 - 2.2.2.6. Contractor: The business(s), corporation(s), or person(s) responsible for the execution of the Construction Contract.
 - 2.2.2.7. Developer: Any person, firm, corporation, or other legal entity improving property for commercial, industrial, institutional, or residential purposes.
 - 2.2.2.8. Development: Any property improved for commercial, industrial, institutional, or residential purposes.
 - 2.2.2.9. Construction: The process of building, altering, repairing, remodeling, improving or demolishing any structure, building, utility or other improvements of any kind to any real property.
 - 2.2.2.10. Construction Plan: Documents, maps or drawings that are prepared by a registered professional engineer that reflect all applicable design standards for the

installation of necessary water facilities or improvements for a subdivision or development and presented for approval.

2.2.2.11. Customer: Any person, firm, group, association, organization, corporation or governmental agency supplied or entitled to be supplied with a water service.

2.2.2.12. Governing Authority: The Chatham County Board of Commissioners is the Governing Authority.

2.2.2.13. Water Utility Right-of-Way/Easement (Exclusive): Right-of-ways or easements granted to the County exclusively for water utilities.

2.3. Abbreviations: Whenever in these detailed specifications the following abbreviations are used, the intent and meaning shall be interpreted as follows:

2.3.1.	AASHTO	American Association of State Highway and Transportation Office
2.3.2.	ACI	American Concrete Institute
2.3.3.	ANSI	American National Standards Institute
2.3.4.	ASCE	American Society of Civil Engineers
2.3.5.	ASTM	American Society of Testing and Materials
2.3.6.	AWWA	American Water Works Association
2.3.7.	FED SPEC	Federal Specifications
2.3.8.	IEEE	Institute of Electrical and Electronics Engineers
2.3.9.	NCDEQ	NC Department of Environmental Quality
2.3.10.	NC DOT	North Carolina Department of Transportation
2.3.11.	NEC	National Electrical Code
2.3.12.	NEMA	National Electrical Manufacturer's Association
2.3.13.	NESC	National Electrical Safety Code
2.3.14.	NFPA	National Fire Protection Association
2.3.15.	OSHA	Occupational Safety and Health Act
2.3.16.	SSPC	Steel Structures Painting Council
2.3.17.	UL	Underwriters' Laboratories, Inc.
2.3.18.	USCOE	United States Army Corps of Engineers (also USACOE)

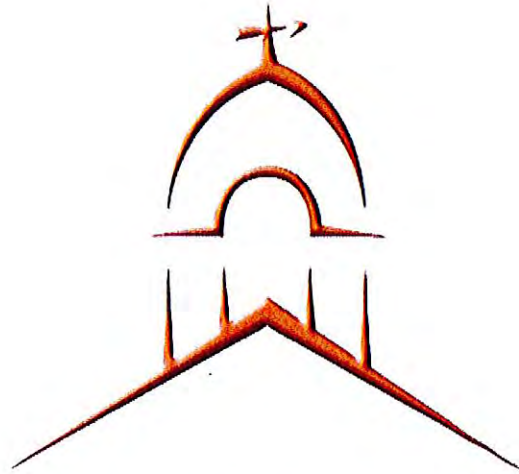

CHATHAM COUNTY
NORTH CAROLINA

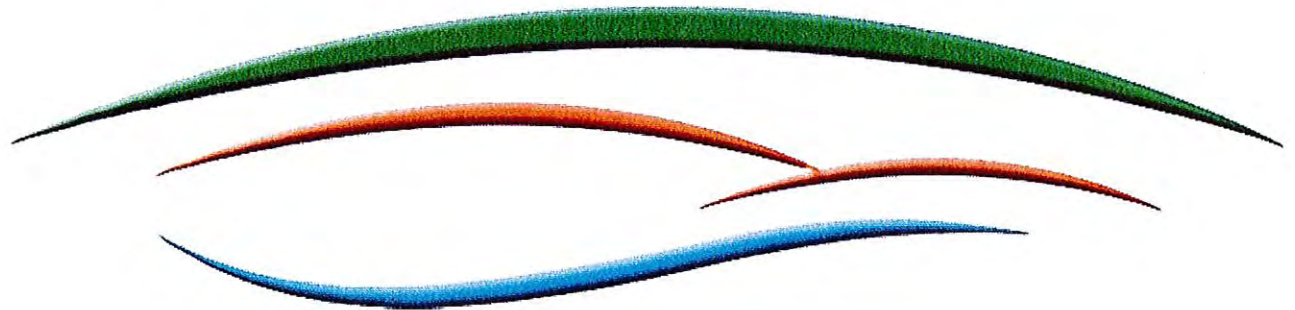

TECHNICAL SPECIFICATIONS

CHATHAM COUNTY PUBLIC UTILITIES & WATER DIVISION
WATER DISTRIBUTION SYSTEM
TECHNICAL SPECIFICATIONS

1. GENERAL

1.1. REQUIREMENTS

1.1.1. The foreman of the contracting crew must speak fluent English.

1.2. LEAD FREE

1.2.1. In accordance with the amended Safe Drinking Water Act for Reduction of Lead in Drinking Water, all products with a wetted surface in contact with potable water shall have the "NL" designation for "no-lead" and shall be lead free, as defined in the rule. Nothing in these specifications shall be construed to supersede this requirement.

1.3. CORROSION CONTROL

1.3.1. No mild carbon steel fasteners, bolts (i.e., ASTM A307), or harnessing shall be permitted for underground service on water system components. All fasteners, bolts, and harnessing, and rodding shall be 316 stainless steel.

1.4. UNDERGROUND LOCATION

1.4.1. In accordance with the Underground Utility Safety and Damage Prevention Act, all underground facilities shall be provided with tracer wire in accordance with paragraph 3.6 (this includes services and mains).

1.5. SUBMITTALS

1.5.1. Format: Contractor shall submit one (1) paper copy and one (1) electronic copy of any all submittals. All electronic files shall be provided in portable document format (PDF) to the County, unless otherwise approved or requested by the County.

1.5.2. Required Submittals: Contractor shall furnish shop drawings and material specification sheets of all material and items to be installed or delivered. Additionally, submit the results of the bacteriological tests and pressure tests to the County.

1.6. DELIVERY, STORAGE, AND HANDLING

1.6.1. Delivery and Storage

Inspect materials delivered to site for damage. Unload and store with minimum handling. Store materials on site in enclosures or under protective covering. Store plastic piping, jointing materials and rubber gaskets under cover out of direct sunlight. Do not store materials directly on the ground. Keep inside of pipes, fittings, valves and hydrants free of dirt and debris.

1.6.2. Handling

Handle pipe, fittings, valves, hydrants, and other accessories in a manner to ensure delivery to the trench in sound undamaged condition. Take special care to avoid injury to

coatings and linings on pipe and fittings; make repairs if coatings or linings are damaged. Do not place any other material or pipe inside a pipe or fitting after the coating has been applied. Carry, do not drag pipe to the trench. Use of pinch bars and tongs for aligning or turning pipe will be permitted only on the bare ends of the pipe. The interior of pipe and accessories shall be thoroughly cleaned of foreign matter before being lowered into the trench and shall be kept clean during laying operations by plugging or other approved method. Before installation, the pipe shall be inspected for defects. Material found to be defective before or after laying shall be replaced with sound material without additional expense to the Government. Store rubber gaskets that are not to be installed immediately, under cover out of direct sunlight.

2. PRODUCTS

2.1. WATER MAIN MATERIALS

2.1.1. *Ductile Iron Pipe* shall conform to ANSI/AWWA C150/A21.50, ANSI/AWWA C151/A21.51, 350 psi, with asphalt coating and cement mortar lining as indicated below, unless otherwise shown or specified.

2.1.1.1. Joints shall be push-on, mechanical, or restrained conforming to ANSI/AWWA C111/A21.11. Joints for driveway bores shall have factory restrained joints. Field applied restrained joints are not acceptable for driveway bores on this project.

2.1.1.2. Fittings and specials for mechanical joint pipe shall conform to C153/A21.53 (Compact).

2.1.1.3. Linings for pipe and fittings shall be standard thickness cement-mortar in accordance with ANSI/AWWA C104/A21.4.

2.1.1.4. Outside Coating: The outside coating shall be a minimum of 1 mil bituminous paint according to ANSI/AWWA C151/A21.51 Section 51-8.1.

2.1.2. *Polyvinyl chloride (PVC) pipe:*

2.1.2.1. Water Mains 4-inch through 12-inch: Pipe, AWWA C900, shall be plain end or gasket bell end, Pressure Class 235 (DR 18) with cast-iron-pipe-equivalent OD, unless specific design pressure dictate a higher pressure rating.

2.1.2.2. Water Mains 14-inch through 36-inch: AWWA C905.

2.1.2.3. Joints and Jointing Material: Joints for pipe shall be push-on joints, ASTM D3139. Joints between pipe and metal fittings, valves, and other accessories shall be push-on joints ASTM D3139, or compression-type joints/mechanical joints, ASTM D3139 and AWWA C111/A21.11. Provide each joint connection with an elastomeric gasket

suitable for the bell or coupling with which it is to be used. Gaskets for push-on joints for pipe, ASTM F477. Gaskets for push-on joints and compression-type joints/mechanical joints for joint connections between pipe and metal fittings, valves, and other accessories, AWWA C111/A21.11, respectively, for push-on joints and mechanical joints.

2.1.3. *High density polyethylene (HDPE) pipe:*

2.1.3.1. Water Mains 4-inch through 63-inch: Pipe, tubing, and heat-fusion fittings shall conform to AWWA C906, minimum DR 11.

2.1.4. *Pipe Locator Wire:* Pipe locator wire shall be installed on all main lines as per Section 3.6.

2.2. MECHANICAL JOINT DUCTILE IRON FITTINGS AND SPECIALS:

Fittings and specials shall be ANSI/AWWA C153/A21.53 (Compact) with joint meeting ANSI/AWWA C111/A21.1. Ductile iron fittings and specials shall be cement-mortar lined (standard thickness) in accordance with ANSI/AWWA C104/A21.4 with outside asphaltic coating.

2.3. MECHANICAL JOINT RESTRAINT GLAND:

2.3.1. Mechanical joint restraint shall be incorporated in the design of the follower gland and shall include a restraining mechanism which, when actuated, imparts multiple wedging action against the pipe, increasing its resistance as the pressure increases. Flexibility of the joint shall be maintained after burial.

2.3.2. Glands shall be manufactured of ductile iron conforming to ASTM A536-80. Restraining devices shall be of ductile iron heat treated to a minimum hardness of 370 BHN. Dimensions of the gland shall be such that it can be used with the standardized mechanical joint bell and tee-head bolts conforming to ANSI/AWWA A21.11 and ANSI/AWWA C153/A21.53 of latest revision. Twist-off nuts shall be used to insure proper actuating of the restraining devices. Any nuts, bolts, and rodding required shall be 316 stainless steel.

2.3.3. The Mechanical joint restraint device shall have a working pressure of at least 150 psi with a minimum safety factor of 3:1.

2.3.4. Restraint glands shall be "Megalug" as manufactured by EBAA Iron, Inc., or "Camlok" as manufactured by Smith-Blair, Inc. Rodding shall be situation specific (with stainless steel rods and nuts). EBAA Iron, Inc. products are listed below as a base and reference for equivalent products by Smith-Blair, Inc. or equal:

2.3.4.1. Ductile iron pipe applications

"Megalug Series 1100" mechanical joint
"Megalug Series 1700" push joint

2.3.4.2. PVC pipe applications

3-48inch DI mechanical joint fittings: "Megalug Series 2000PV"

C-900 push joints: "Megalug Series 1600"

C-905 push joints: "Megalug Series 2800"

ASTM D2241, IPS, SDR 21 push joints: "Megalug Series 6500"

2.4. PACKING MATERIALS AND JOINTS:

No contaminated material or any material capable of supporting prolific growth of micro-organisms shall be used for sealing joints. The lubricant used in the installation of sealing gaskets shall be suitable for use in potable water and shall conform to AWWA C111/A21-11. It shall be delivered to the job in enclosed containers and shall be kept clean. If proven contaminated soil conditions exist, Nitrile, Neoprene, or other special gaskets may be required by Chatham County.

2.5. VALVES

2.5.1. *Gate Valves:* Gate valves 4-inch and larger shall conform to AWWA C-509, resilient seated type with non-rising stem. Gate valves shall have ductile iron body, bonnet, and wedge with 250 pressure rating. Valves shall be fully ported. Valves 14-inch and larger shall have gear operator. Valves shall have 2-inch operating nut, open left (CCW), and shall have triple O-ring seals. Valve ends shall be mechanical joint, unless otherwise shown or specified. Fusion bonded coating shall comply with ANSI/AWWA C550. Wedge shall be rubber encapsulated with 100% leak tight closure. Valves shall bear NSF-61 approval. Valves shall be manufactured by Mueller, American Darling or Clow Corporation or approved equal. 2-inch gate valves shall meet above specification with threaded or mechanical joint ends as required.

2.5.2. *Valve Boxes:* Valve boxes shall be cast iron screw adjustment type with flared base. The word "WATER" shall be cast in the cover. The boxes shall be of such length as will be adapted, without full extension, to the depth of cover required over the pipe at the valve location. Boxes shall be installed over each gate valve, unless otherwise shown or specified. Valve boxes shall conform to ASTM A48 "Grey Iron Castings" Class 30B or approved equal.

2.5.3. *Valve Box Concrete Collars:* Valve boxes in unpaved areas shall be installed with pre-cast concrete collars.

2.5.4. *Tapping Sleeves And Valves:* With the exception of the valve ends and other

modifications necessary for tapping service, tapping valves shall conform to AWWA C509. Each tapping valve shall be provided with a flanged inlet and designed, faced, and drilled for attachment to the outlet flange of the tapping sleeve; with an outlet end provided with a tapping flange for attachment of a standard drilling machine; and also with a mechanical joint type bell and for connection of the branch main. Tapping sleeves shall be rated for 250 psi (12-inches and smaller) of the flanged outlet type designed for attachment to the flanged inlet end of the tapping valve. Body, straps, studs, bolts, and outlet flange shall be stamped 316 stainless steel. All welds shall be fully passivated for corrosion resistance. Outlet gaskets shall be Buna-N and 360-degree full gasket shall be gridded virgin SBR compounded for water service per ASTM D2000. Tapping sleeves shall be Ford Meter Box "Style FAST" or equal.

2.5.5. *Pressure Reducing Valves:* Pressure reducing valves shall maintain a constant downstream pressure regardless of fluctuations in demand. Valves shall be suitable for 200 psi operating pressure on the inlet side, with outlet pressure set for 75psi. The valves shall be of the hydraulically-operated, pilot controlled, globe or angle type, and may be actuated either by diaphragm or piston. The pilot control shall be the diaphragm-operated, adjustable, spring-loaded type, designed to permit flow when controlling pressure exceeds the spring setting. Ends shall be flanged. Valve bodies shall be bronze, cast iron or cast steel with bronze trim. Valve stem shall be stainless steel. Valve discs and diaphragms shall be synthetic rubber. Valve seats shall be bronze. Pilot controls shall be bronze with stainless steel working parts. The valve shall be as manufactured by APCO, CLA-VAL, and Mueller or approved equal.

2.5.6. *Vacuum and Air Relief Valves:* Combination air release valves shall be installed at high points in the water main as indicated by the plans in order to release air in the main as the main is filling and allow air to enter the system when draining or subject to negative pressure. Combination air release valves shall be manufactured to meet or exceed the requirements of **ANSI/AWWA C512**, latest revision.

The valves shall be 2" NPT screwed or ANSI Class 125 flanged inlet connection and shall be cast iron body, top and inlet flange (where required), stainless steel float and trim with buna-n seat. Valves, which operate the pressure plunger via a single lever and fulcrum, will not be acceptable. A protectop shall be supplied to prevent debris from entering the outlet of the valve. The valves shall be Crispin (Model UL20), A.R.I. (Model D-050), Apco (No. 200A), Cla-Val (33A), or an approved equal.

2.6. FIRE HYDRANTS:

Hydrant valves shall open left. Hydrants shall be iron body, fully bronze mounted, dry barrel type with breakaway flange and stem coupling conforming to AWWA C502, with valve opening not less than 4.5-inches in diameter. Hydrants shall have a 6-inch mechanical joint connection on the inlet end. The hydrants shall have two (2) 2-1/2" hose nozzles with caps, and one (1) 4-1/2" pumper nozzle and cap. The nozzles shall have American National Standard fire hose coupling threads. Working parts shall be bronze. Hydrants shall be

manufactured by American Darling (MK 73), Mueller (Super Centurion 250), CLOW (Medallion), or Kennedy (Guardian K-81D).

2.7. WATER SERVICE LINE MATERIALS:

Pipe shall be polyethylene (PE) tubing, SDR 9, 200 psi, conforming to ASTM D2737/AWWA C901. No joint shall be installed between the main service tap and the meter stop. In proven contaminated soil conditions, copper (Type K) services may be required, ASTM B88.

2.7.1. *Service Saddles:* Saddles on ductile iron pipe shall be wide band brass body with stainless steel strap, Ford Style 202BSD for Iron Pipe, or approved equal. Saddles on PVC pipe shall be brass with dual stainless steel straps designed for use on PVC (and comply with AWWA and Uni-Bell stipulations for PVC) pipe providing full circle support without cracking or distorting the pipe, Ford Style 202BSD for PVC, or approved equal. Size of tap shall match that of the service line.

2.7.2. *Corporation Stop:* Corporation stops shall comply with AWWA C800. Connection stop shall have compression nut and gasket service line connections. Size of corporation stop shall match that of service line. Corporation stop shall be manufactured by Ford Meter Box Company (Model F1001 Ballcorp) or approved equal. Stainless steel insert stiffeners shall be used on all compression fittings.

2.7.3. *Curb Stop:* Curb stop shall be Ford Meter Box Company (Model B66-XXX-NL), or approved equal.

2.7.4. *Pipe Locator Wire:* Pipe locator wire shall be installed on all service lines as per Section 3.6.

2.7.5. *Water Meter Boxes:* Boxes shall be cast iron or plastic with cover complete with lifting lug and a metal read lid. Cast iron boxes conforming to ASTM A48, Class 30B, meeting H20 Loading Standards, shall be used in traffic areas. Single meter box shall be Model D1200-DICIR as manufactured by DFW/HPI or approved equal. Dual service line boxes shall be jumbo heavy duty boxes with solid lid and shall be Model D1500-DICIR as manufactured by DFW/HPI or approved equal.

3. EXECUTION

3.1. GENERAL:

Install ductile iron pipe in strict conformance with AWWA C600. Install PVC pipe in strict conformance of AWWA C605. Minimum depth of bury above the top of pipe shall be 36 inches unless ductile iron pipe is used. Install other plastic pipe in conformance with ASTM D2774 and recommended practices of the manufacturer.

3.2. PIPING BENEATH RAILROAD RIGHT-OF-WAY:

Piping passing under the right-of-way of a commercial railroad shall conform to the specifications for pipelines conveying nonflammable substances in Chapter 1, Part 5 of the AREMA Eng Man, except for casing pipe, provide ductile-iron pipe in lieu of cast-iron pipe. Ductile-iron pipe shall conform to and have strength computed in accordance with ASTM A 746.

3.3. CUTTING OF PIPE:

Cut pipe in a neat and workmanlike manner without damage to the pipe or its lining.

3.4. PIPE SEPARATIONS:

The following minimum pipe separations will be maintained:

3.4.1. *Parallel to Sanitary Sewer Piping*

3.4.1.1. Normal Conditions: Water Piping shall be laid at least **10 feet** horizontally from a sewer, sewer manhole, or force main whenever possible. Distance shall be measured edge to edge.

3.4.1.2. Unusual Conditions: When local conditions prevent a horizontal separation of **10 feet**, water piping may be laid closer to a sewer, sewer manhole, or force main provided: Bottom of the water piping shall be at least 18 inches above the top of the sewer piping. Where this vertical separation cannot be obtained, water and sewer piping shall be constructed of AWWA-approved ferrous material, pressure tested in place without leakage prior to backfilling. Sewer manhole shall be watertight construction and tested in place.

3.4.2. *Crossing Sanitary Sewer Piping*

3.4.2.1. Normal Conditions: Water Piping shall cross above sewer piping and shall be laid to provide a separation of at least 18-inches between the bottom of the water piping and the top of the sewer piping.

3.4.2.2. Unusual Conditions: When local conditions prevent normal conditions described above, installation shall adhere to all of the following conditions:

3.4.2.2.1. Water Over Sewer (less than 18-inch separation): Both water and sewer piping shall be constructed of AWWA approved ductile iron pipe, with joints that are equivalent to water main standards, with the pipes center such that the joints are equidistant apart. Only full lengths of pipe (18-foot minimum) shall be used in this scenario.

3.4.2.2.2. Water Under Sewer (regardless of separation): Both water and sewer piping shall be constructed of AWWA approved ductile iron pipe, with joints that are equivalent to water main standards, with the pipes center such that the joints are equidistant apart. Only full lengths of pipe (18-foot minimum) shall be used in this scenario. Additionally, adequate structural support for sewer piping to prevent excessive deflection of joints and settling over water piping.

3.4.3. *Sanitary Sewer Manholes:*

No water piping shall pass through or come in contact with any part of a sewer manhole.

3.4.4. *Drain-Fields and Spray-Fields:*

No water piping shall be laid less than 25 feet horizontally from any portion of a wastewater or septic drainfield or spray-field.

3.5. JOINT DEFLECTION:

Maximum joint deflection shall meet requirements of AWWA C600 or AWWA Manual of Practice M23.

3.6. PIPE LOCATOR WIRE:

A 10 gauge insulated copper wire shall be run continuously along the pipe and shall be securely taped to the water line and all service laterals. All splices in the wire shall be made by use of an underground rated, watertight, and approved splice connector. No twisting of wire ends is permitted. The locator wire shall not be wrapped around the pipe, flanges, bells, valves, or other appurtenances. The locator wire shall be accessible above ground at one thousand feet (1,000') intervals and shall be protected by a cast iron box with cover marked "water" with a concrete collar. At valve boxes, the wire shall be brought up on the outside of the box and folded under lid.

3.7. JOINTING OF PIPE

3.7.1. *Keeping Pipe Clean And Dry:* Precautions shall be taken to protect pipe interiors, fittings and valves against contamination. Pipe delivered for construction shall be strung so as to minimize entrance of foreign material.

3.7.2. When pipe laying is not in progress, for example, at the close of the day's work, all openings in the pipeline shall be closed by water-tight plugs. Joints of all pipe in the trench shall be completed before work is stopped. If water accumulates in the trench, the plugs shall remain in place until the trench is dry. It is recommended that only the amount of pipe to be installed that day be strung out.

3.7.3. Delay in placement of delivered pipe invites contamination. The more closely the rate of delivery is correlated to the rate of pipe laying, the less this delay. If the dirt will not be removed by the flushing operation in the opinion of the Engineer, the interior of the pipe shall be cleaned and swabbed as necessary, with a five (5%) percent hypochlorite disinfecting solution.

3.7.4. *Ductile-Iron Pipe* shall be installed in accordance with AWWA C600, modified as necessary by the recommendations of the manufacturer.

3.7.5. *PVC Pipe* shall be installed in accordance with AWWA Manual of Practice M23,

modified as necessary by the recommendations of the manufacturer.

3.7.6. Connections

- 3.7.6.1. Connections between different types of pipe and accessories shall be made with transition fittings approved by the Owner's Representative.
- 3.7.6.2. When joining C-900/905 PVC pipe to ductile iron pipe the bevel of the spigot should be made to look like the bevel of the product to which it is being joined. Make a ductile iron pipe bevel longer than that which is normally supplied on a ductile iron spigot, and make a PVC pipe bevel shorter than that which is normally supplied on a PVC pipe spigot. Use pipe beveled at the factory as a guide.
- 3.7.6.3. The depth of insertion of the assembly should be adjusted to reflect the assembly mark found at the spigot end of the pipe bell used. Adjust the assembly mark to be shorter on a PVC spigot; and adjust the assembly mark to be longer on a ductile iron spigot.

3.7.7. *Service Laterals:* Service laterals shall consist of a tapping saddle, corporation stop and a length of PE pipe with no joint installed between the main service tap and the service stop. Service laterals shall be installed perpendicular to the water main. Contractor shall install all material per the detail allowing for meter installation at a later date by Chatham County personnel. Tracing wire shall be installed as per Section 3.6.

3.8. SETTING OF VALVES, VALVE BOXES, AND FIRE HYDRANTS

- 3.8.1. Install where shown or directed and set plumb on a brick foundation. Valve boxes shall be centered on the valves. Boxes shall be installed over each outside gate valve. Where feasible, valves shall be located outside the area of roads and streets. Earth fill shall be carefully tamped around each valve box to a distance of 4 feet on all sides of the box, or to the undisturbed trench face if less than 4 feet.
- 3.8.2. After delivery, valves shall be drained to prevent freezing and shall have the interiors cleaned of all foreign matter before installation. Valves shall be fully opened and fully closed to insure that all parts are in working condition.

3.9. RESTRAINING AND BLOCKING

The plugs, caps, tees and bends deflecting 11-1/4 degrees or more either vertically or horizontally on water lines 6 inches in diameter or larger shall be provided with thrust blocking or "Megalug" or Camlok retainer gland at each joint, installed per manufacturer's requirements. Blocking shall be placed between solid ground and the fitting to be anchored. Unless otherwise indicated or directed, the base and thrust bearing sides of the thrust blocks shall be poured directly against undisturbed earth. The sides of thrust blocks not subject to thrust may be poured

against forms. The area of bearing shall be as shown on the plans or as directed. Blocking shall be placed so that the fitting joints will be accessible for repair. Rods and clamps shall be stainless steel.

- 3.10. FIRE HYDRANTS: Locate and install as shown on the drawings. Each hydrant shall be connected to the main with a 6-inch branch line. Hydrants shall be set plumb with the pumper nozzle facing the roadway and with the center of the lowest outlet not less than 18 inches above the finished surrounding grade and the operating nut not more than 48 inches above the finished surrounding grade. The hydrant shall be set in a bed of crushed rock, which shall surround the barrel at least 12 inches in all directions. Hydrants shall be restrained with stainless steel tie rods extending from the main line tee to the hydrant, or by combination of tie rods and blocking or by "Megalug" retainer glands at each joint per manufacturer's requirements. Hydrant valves shall be located at the main as close to the tee or tap as possible.

3.11. HYDROSTATIC TESTING

Where any section of a water line is provided with concrete thrust blocking, the hydrostatic test shall not be made until at least 5 days after installation of the concrete thrust blocking unless otherwise approved. The method proposed for disposal of wastewater from hydrostatic tests and disinfection shall be submitted to the Owner's representative prior to performing hydrostatic tests. Use clean potable water for all testing of lines. Hydrostatic testing shall be conducted on all water mains and service lines in accordance with the applicable specified standard, except for the special testing requirements given in the paragraph entitled "Special Testing Requirements."

3.11.1. *Ductile Iron Mains*: Test ductile-iron water mains and water service lines in accordance with the requirements of AWWA C600 for hydrostatic testing. The amount of leakage on ductile-iron pipelines with mechanical-joints or push-on joints shall not exceed the amounts given in AWWA C600; no leakage will be allowed at joints made by any other method.

3.11.2. *PVC Mains*: Test PVC plastic water mains and water service lines made with PVC plastic water main pipe in accordance with the requirements of AWWA C605 for pressure and leakage tests. The amount of leakage on pipelines made of PVC plastic water main pipe shall not exceed the amounts given in AWWA C605, except that at joints made with sleeve-type mechanical couplings, no leakage will be allowed.

3.11.3. *Water Service Lines*: Test water service lines in accordance with applicable requirements of AWWA C600 for hydrostatic testing. No leakage will be allowed at copper pipe joints copper tubing joints (soldered, compression type, brazed) plastic pipe joints flanged joints and screwed joints.

3.11.4. *Special Testing Requirements*: For pressure test, use a hydrostatic pressure 50 psi greater than the maximum working pressure of the system, except that for those portions of the

system having pipe size larger than 2 inches in diameter, hydrostatic test pressure shall be not less than 200 psi. Hold this pressure for not less than 2 hours. Prior to the pressure test, fill that portion of the pipeline being tested with water for a soaking period of not less than 24 hours. For leakage test, use a hydrostatic pressure not less than the maximum working pressure of the system. Leakage test may be performed at the same time and at the same test pressure as the pressure test.

3.12. DISINFECTION

- 3.12.1. Each unit of constructed water main shall be disinfected with chlorine upon successful completion of the hydrostatic test. The disinfection procedure shall be performed in strict conformance with the Chatham County Procedures for Disinfecting Water Mains, as outlined below.
- 3.12.2. The Contractor shall be responsible for furnishing and installing all required chlorine injection and monitoring ports at no additional cost to the Chatham County.
- 3.12.3. The mains will in no case be accepted by the Chatham County for public use until Chatham County approves the mains as having been properly disinfected.

3.12.4. *Disinfecting Water Mains*

- 3.12.4.1. Prior to disinfection, obtain Engineer approval of the proposed method for disposal of waste water from disinfection procedures.
- 3.12.4.2. Disinfect new water piping and existing water piping affected by Contractor's operations in accordance with AWWA C651, for the Continuous Feed Method, along with Section .1003 of The Rules Governing Public Water Systems.
- 3.12.4.3. Fill piping systems with solution containing minimum of 50 parts per million of available chlorine and allow solution to stand for minimum of 24 hours. Chlorine concentration after 24 hours must be at least 10 parts per million.
- 3.12.4.4. Flush solution from the systems with domestic water until maximum residual chlorine content is within the range of 0.2 and 0.5 parts per million, or the residual chlorine content of domestic water supply. Obtain at least two consecutive satisfactory bacteriological samples from new water piping, analyze by a state-approved certified laboratory, and submit the results prior to the new water piping being placed into service.

END OF SECTION



CHATHAM COUNTY
NORTH CAROLINA

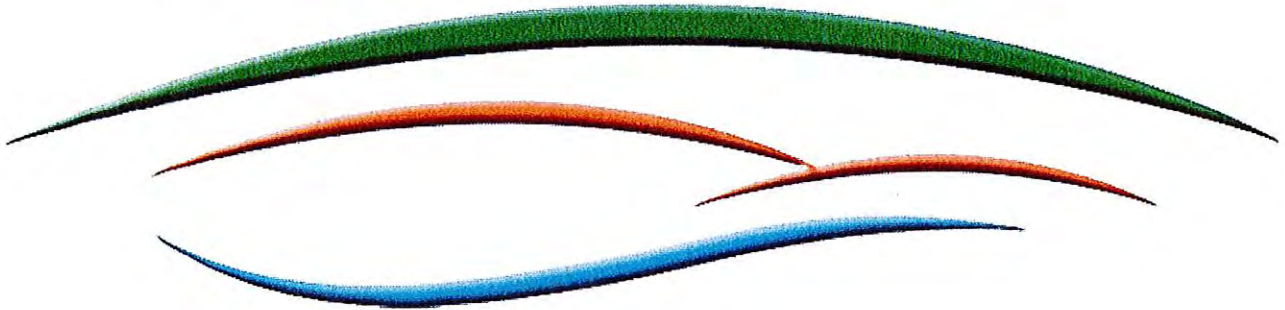

**DETAILED STANDARD
DRAWINGS**

Detail

No.	Detail Description
1	Fire Hydrant Assembly
2	Typical Fire Hydrant & Gate Valve with Gradelok
3	Gate Valve Assembly
4	Valve Box and Collar Not in Pavement
5	Valve Box and Collar in Pavement
6	Valve Box Cover
7	Valve Marker Post
8	4" - 24" Tapping Sleeve Assembly
9	Wrap Around Connection Assembly
10	Jumper Connection
11	Standard Water Air Release Valve
12	Permanent Water Main Blow-Off Assembly
13	2" Blow-Off Assembly at End of Water Main
14	Automatic Flushing Assembly
15	Yard Hydrant
16	Standard 3/4" & 1" Water Service Installation
17	Water Meter Box
18	1 1/2" - 2" Meter Service Connection
19	4" - 8" Domestic Meter with Bypass
20	4" Meter Vault
21	6" - 10" Fire and Domestic Meter Service with Bypass
22	6" - 10" Meter Vault
23	Irrigation Tap on New and Existing Services
24	Fire, Domestic & Irrigation Options Schematic
25	Gang Meter Assembly
26	Gang Meter Addressing Multi-Story Building
27	Gang Meter Addressing Single Story Building
28	Double Check Valve Assembly
29	Double Detector Check Valve Assembly
30	Double Check Valve and Double Detector Check Valve Below Ground Installation
31	Reduced Pressure Zone Backflow Preventer Assembly
32	Boring and Spider Assembly
33	Boring Pipe Alignment Guide
34	Directional Bore
35	Ductile Iron Pipe Trench Bottom Dimensions and Backfilling Requirements
36	PVC Pipe Trench Bottom Dimensions and Backfilling Requirements
37	Standard Thrust Blocking Views
38	Concrete Thrust Blocking Quantity Table, 6" - 16" Pipe
39	Concrete Thrust Blocking Quantity Table, 24" - 48" Pipe
40	Concrete Thrust Blocking for Water Mains
41	Concrete Thrust Blocking for Valves and Dead Ends
42	4" - 24" Restrained Tee and Valve on Dead Ends
43	Vertical Bend Assembly
44	Concrete and Asphalt Open Cut and Patch
45	Water and Sewer Crossing
46	Stream Crossing and Bank Stabilization
47	Temporary Meter Fencing Protection

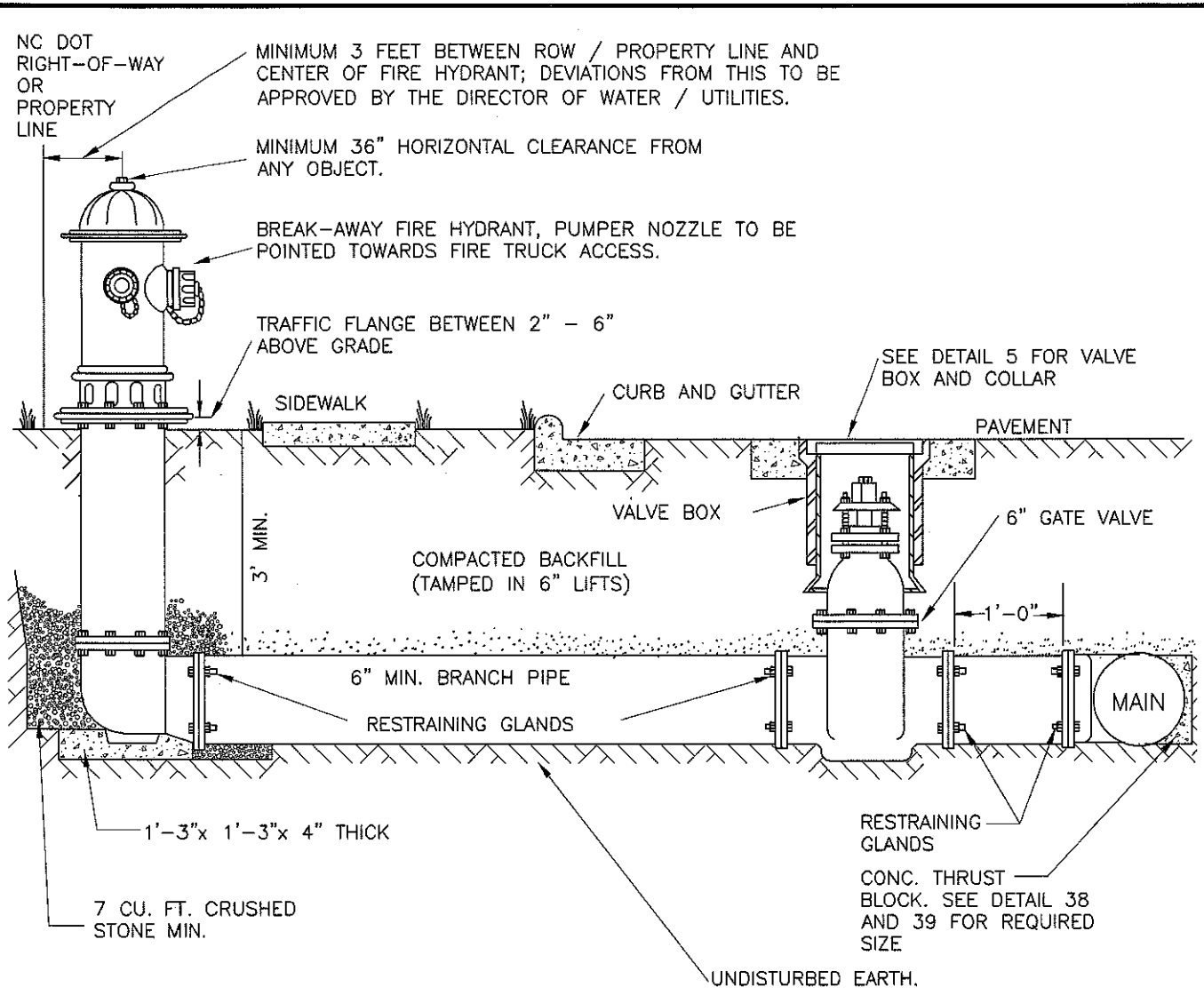

NOTES:

1. FIRE HYDRANT SHALL BE AS MANUFACTURED BY: MUELLER, AMERICAN DARLING, KENNEDY OR CLOW.
2. BRANCH PIPE SHALL BE DUCTILE IRON AWWA C150
3. 6" GATE VALVE SHALL BE AWWA C500 OPEN LEFT
4. STEEL RODS AND BOLTS SHALL BE 3/8" HOT DIPPED GALVANIZED
5. FIRE HYDRANTS WILL BE INSTALLED IN TRUE VERTICAL POSITION
FIRE HYDRANTS TO BE LOCATED IN ROW OR 5 FOOT EASEMENT ADJACENT TO ROW

ANYTIME SITE WORK, CONSTRUCTION, ROAD WORK, OR ANY OTHER WORK CHANGES THE GRADE OF THE FIRE HYDRANT, THE PERSON RESPONSIBLE FOR THE WORK IS RESPONSIBLE FOR ADJUSTING THE FIRE HYDRANT TO STAY WITHIN COMPLIANCE.

DETAIL	FIRE HYDRANT ASSEMBLY	CHATHAM COUNTY PUBLIC UTILITIES & WATER DIVISION	 CHATHAM COUNTY NORTH CAROLINA
1		P.O. BOX 910 PITTSBORO, NC 27312	
REVISION DATE		964 EAST STREET, SUITE 205 PITTSBORO, NC 27312 (919) 852-8270 (BUS) (919) 852-8282 (FAX)	
JULY 1, 2015			

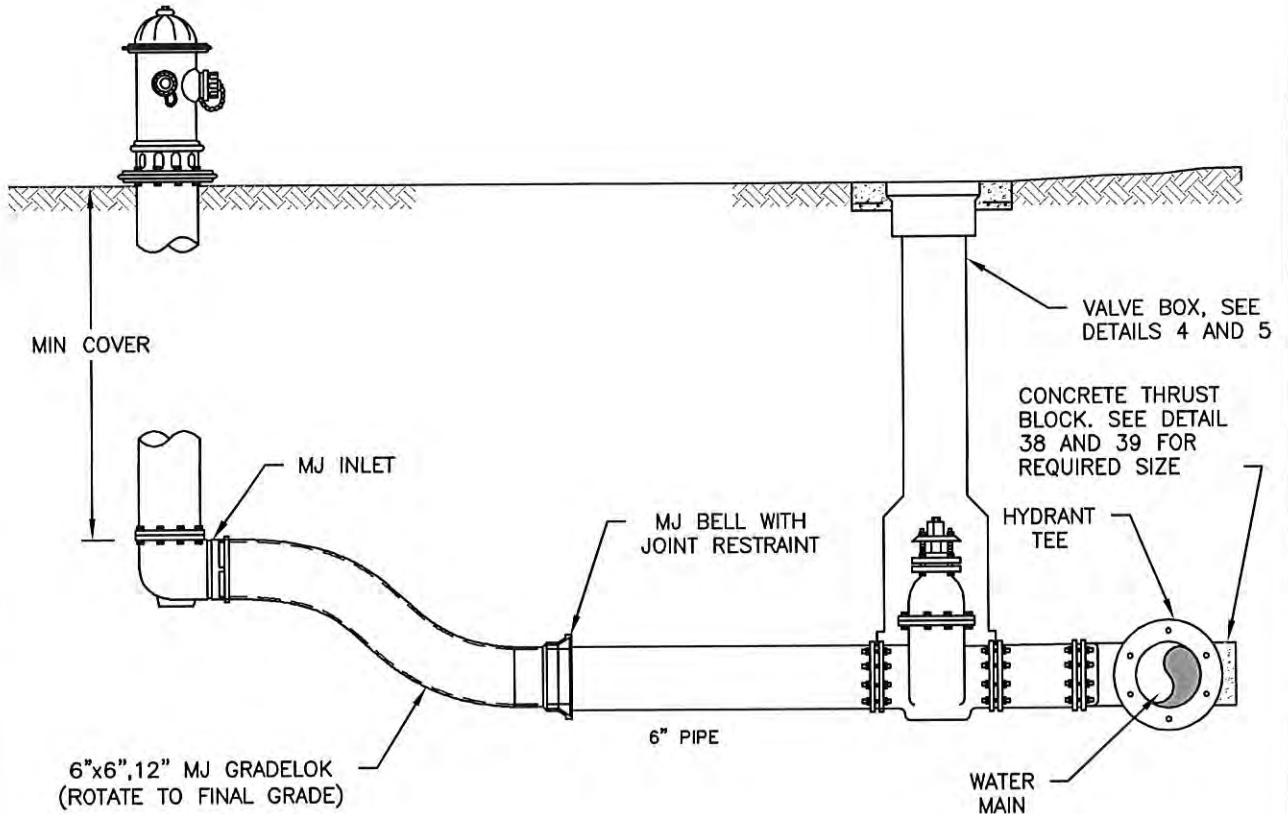

NOTES:

1. REFER TO DETAIL 1 FOR FURTHER NOTES, PLACEMENT BACKFILL, AND OTHER RELEVANT INFORMATION.

DETAIL	<h2 style="margin: 0;">TYP. FIRE HYDRANT & GATE VALVE WITH GRADELOK</h2>	<p>CHATHAM COUNTY PUBLIC UTILITIES & WATER DIVISION</p> <p>P.O. BOX 910 PITTSBORO, NC 27312</p> <p>964 EAST STREET, SUITE 205 PITTSBORO, NC 27312</p> <p>(919) 852-8270 (BUS) (919) 852-8282 (FAX)</p>	
2			
REVISION DATE			
JULY 1, 2015			

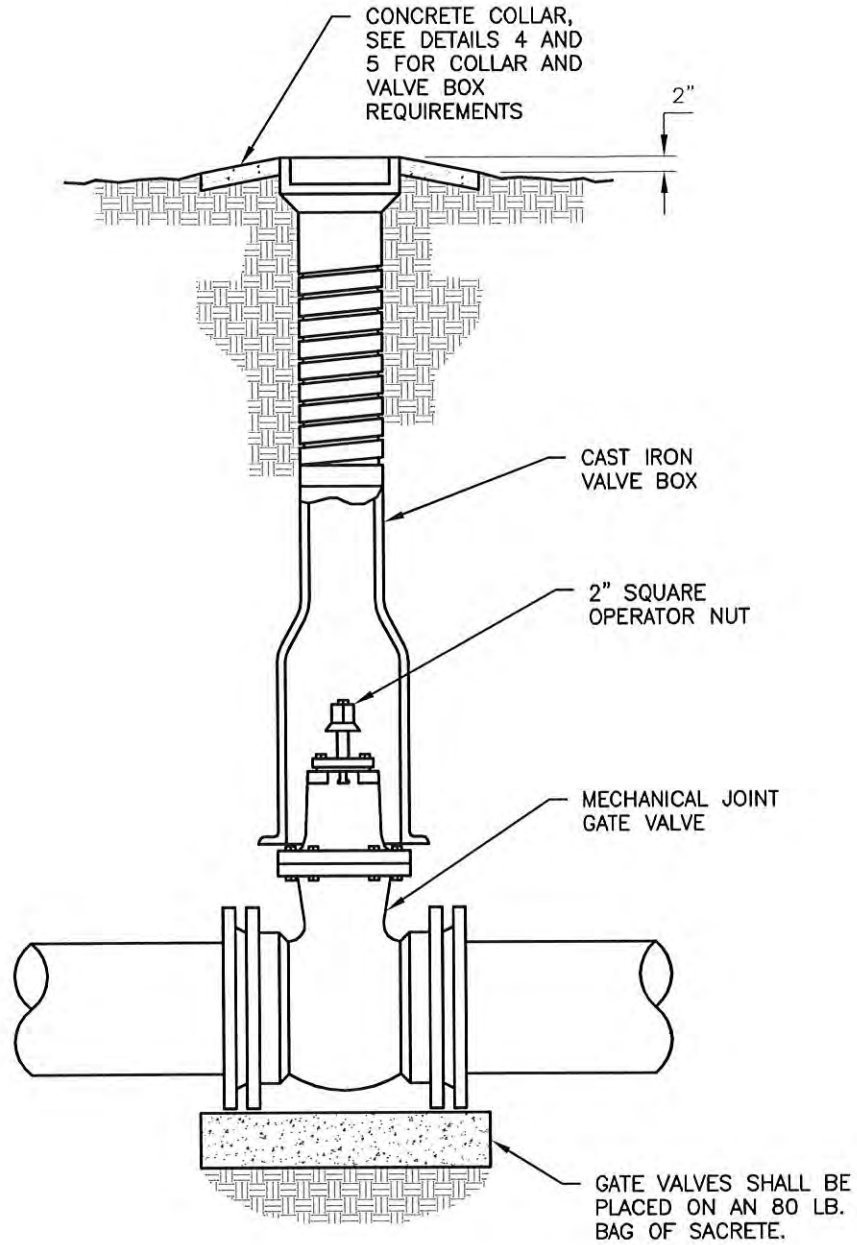

DETAIL
3
REVISION DATE
JULY 1, 2015

GATE VALVE ASSEMBLY

CHATHAM COUNTY
PUBLIC UTILITIES & WATER DIVISION

P.O. BOX 910
PITTSBORO, NC 27312
964 EAST STREET, SUITE 205
PITTSBORO, NC 27312
(919) 852-8270 (BUS)
(919) 852-8282 (FAX)



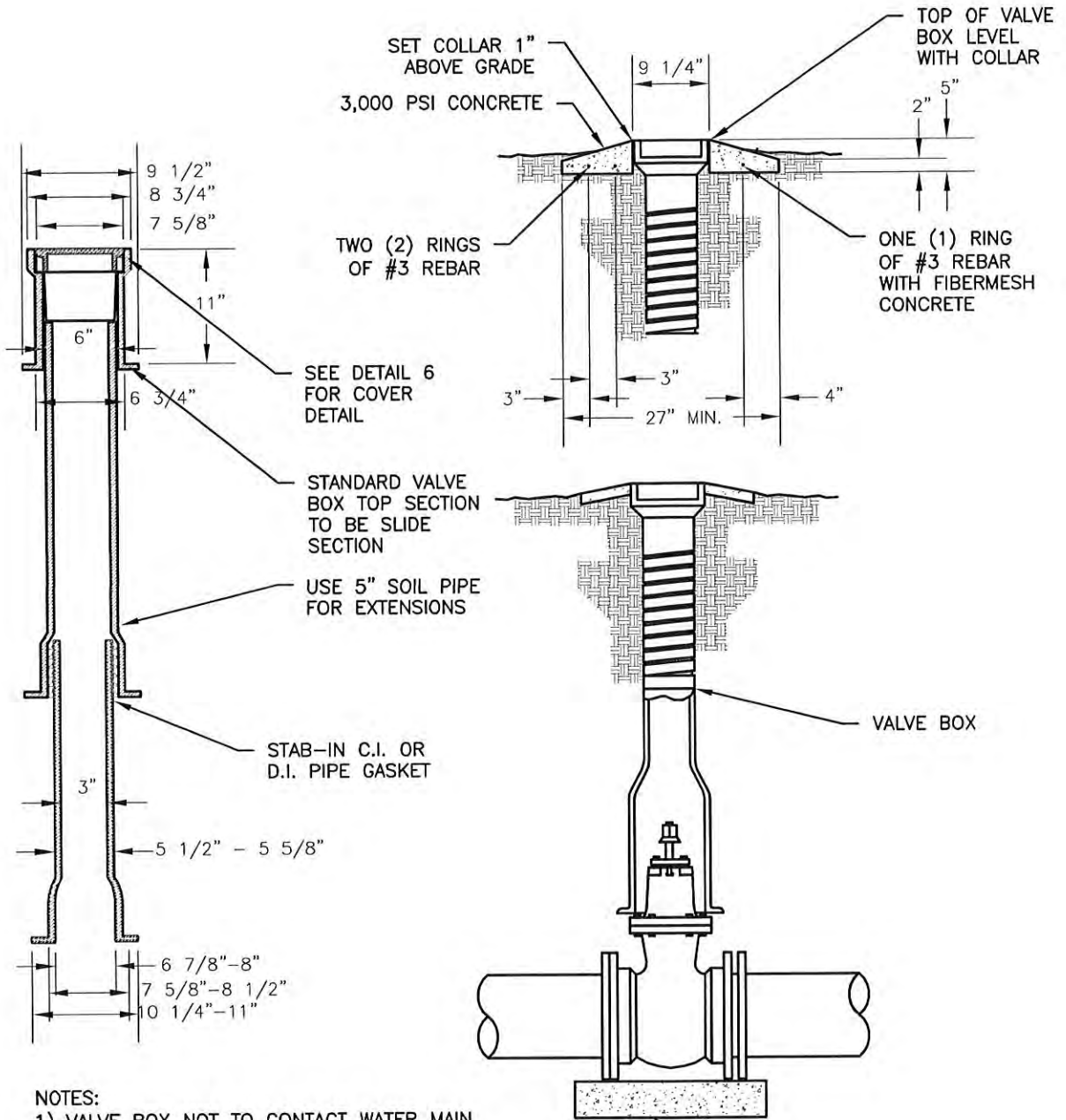

NOTES:

- 1) VALVE BOX NOT TO CONTACT WATER MAIN
- 2) ALL TRAFFIC CASTINGS MUST BE CLASS 35 OR GREATER.
- 3) FOR ANY VALVES OVER 10' DEEP, A VALVE STEM EXTENSION MUST BE USED TO BRING TO A DEPTH OF NO MORE THAN 5', EXTENSION MUST BE A MINIMUM OF 1" SOLID STOCK.
- 4) TOTAL VALVE BOX WEIGHT: MINIMUM OF 85 LBS.

VALVES SHALL BE PLACED ON AN 80 LB. BAG OF SACRETE

DETAIL	<h2>VALVE BOX AND COLLAR NOT IN PAVEMENT</h2>	CHATHAM COUNTY PUBLIC UTILITIES & WATER DIVISION
4		P.O. BOX 910 PITTSBORO, NC 27312
REVISION DATE		964 EAST STREET, SUITE 205 PITTSBORO, NC 27312
JULY 1, 2015		(919) 852-8270 (BUS) (919) 852-8282 (FAX)
		

APPROVED METHOD FOR EXTENSION OF VALVE BOX

NOTE: 2'x 2'x 6" CONCRETE PAD REQUIRED ON ALL VALVES. NO PRECAST CONCRETE DOUGHNUT ALLOWED.

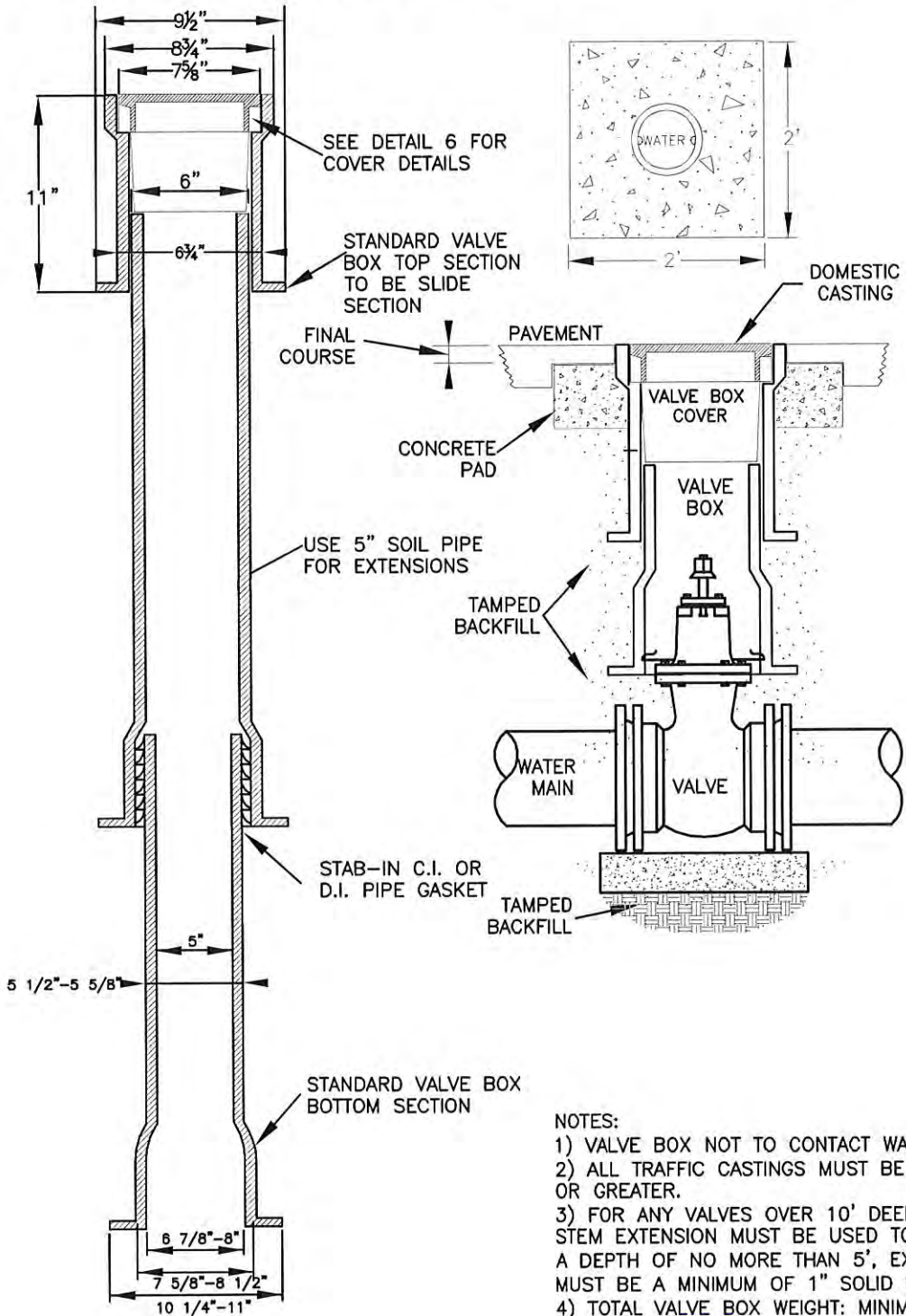

- NOTES:
- 1) VALVE BOX NOT TO CONTACT WATER MAIN
 - 2) ALL TRAFFIC CASTINGS MUST BE CLASS 35 OR GREATER.
 - 3) FOR ANY VALVES OVER 10' DEEP, A VALVE STEM EXTENSION MUST BE USED TO BRING TO A DEPTH OF NO MORE THAN 5', EXTENSION MUST BE A MINIMUM OF 1" SOLID STOCK.
 - 4) TOTAL VALVE BOX WEIGHT: MINIMUM OF 85 LBS.

DETAIL	<h2 style="margin: 0;">VALVE BOX AND COLLAR IN PAVEMENT</h2>	<p>CHATHAM COUNTY PUBLIC UTILITIES & WATER DIVISION</p> <p>P.O. BOX 910 PITTSBORO, NC 27312</p> <p>964 EAST STREET, SUITE 205 PITTSBORO, NC 27312</p> <p>(919) 852-8270 (BUS) (919) 852-8282 (FAX)</p>	
5			
REVISION DATE			
JULY 1, 2015			

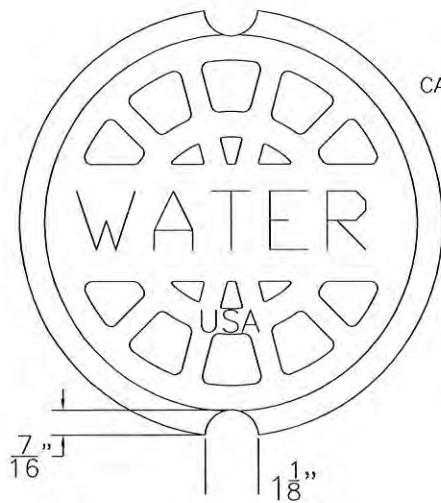

PLAN VIEW

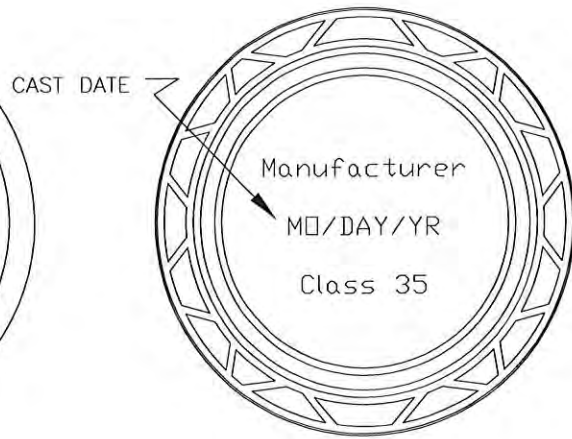

BOTTOM VIEW

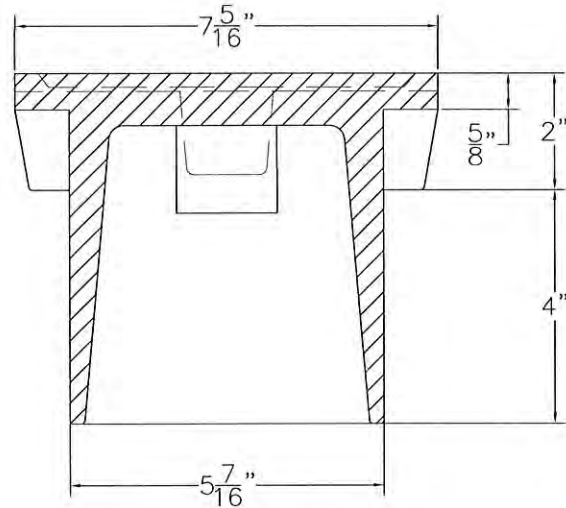

SECTION VIEW

NOTES:

1. "WATER" LETTERING MUST BE 1" RAISED (RECESSED FLUSH)
2. VALVE COVER SHALL BE DOMESTICALLY CAST.
3. COVER MUST HAVE A MINIMUM WEIGHT OF 25 POUNDS.
4. COVER MUST BE CLASS 35 OR GREATER.
5. COVER MUST MEET OR EXCEED AASHTO H-20 LOAD REQUIREMENTS.

DETAIL	<h1>VALVE BOX COVER</h1>	<p>CHATHAM COUNTY PUBLIC UTILITIES & WATER DIVISION</p> <p>P.O. BOX 910 PITTSBORO, NC 27312</p> <p>964 EAST STREET, SUITE 205 PITTSBORO, NC 27312</p> <p>(919) 852-8270 (BUS) (919) 852-8282 (FAX)</p> 
<h1>6</h1>		
REVISION DATE		
JULY 1, 2015		

NOTES:

1. MARKER POST SHALL BE INSTALLED AT THE EDGE OF THE DOT RIGHT-OF-WAY OR PROPERTY LINE.
2. MARKER POST SHALL BE PROVIDED AT ALL VALVES
3. ABBREVIATIONS STAMPED ON POST SHALL BE MV = MAIN VALVE AND BO = BLOW OFF.

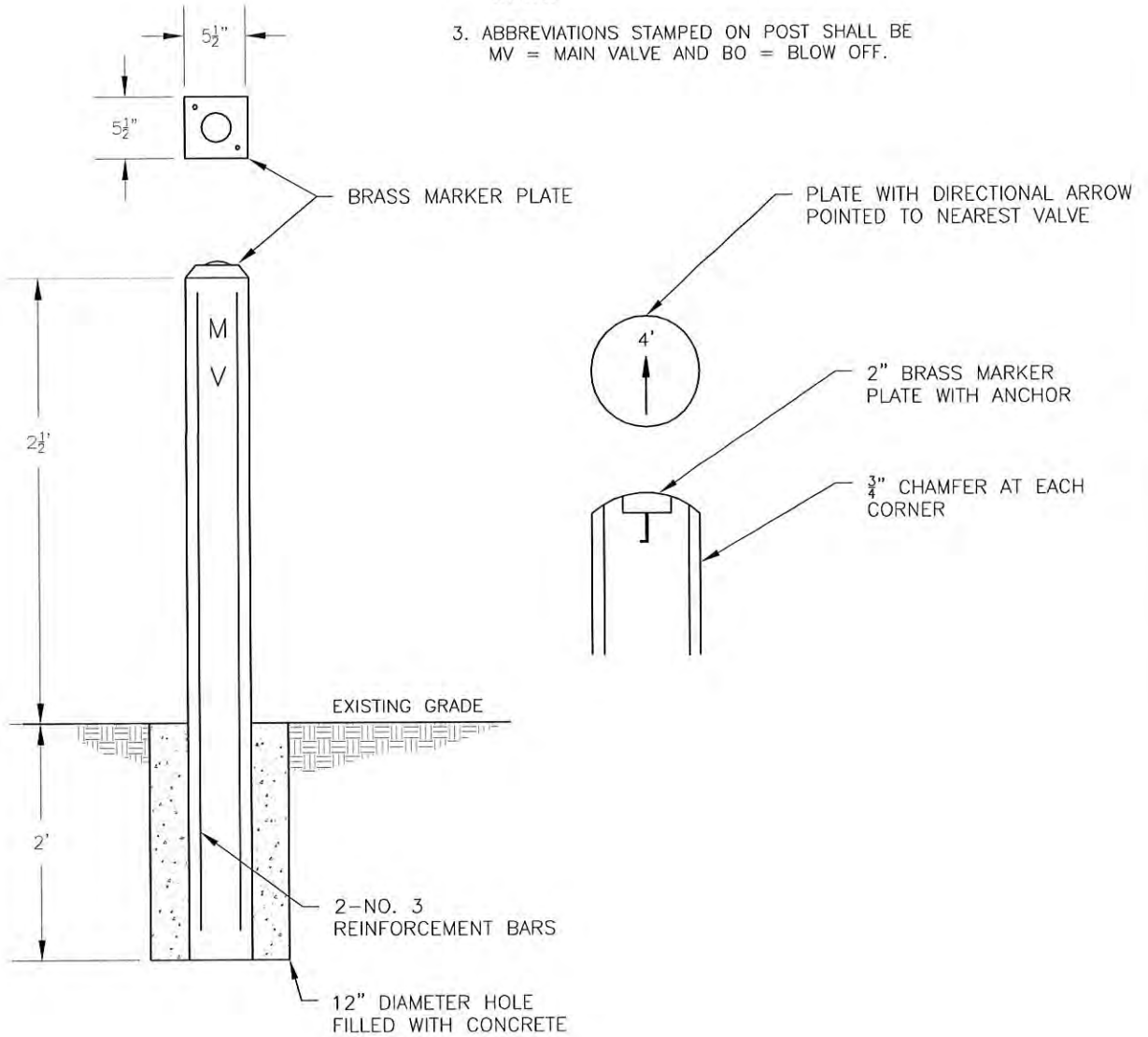

DETAIL	<h1>VALVE MARKER POST</h1>	CHATHAM COUNTY PUBLIC UTILITIES & WATER DIVISION
7		P.O. BOX 910 PITTSBORO, NC 27312
REVISION DATE		964 EAST STREET, SUITE 205 PITTSBORO, NC 27312
JULY 1, 2015		(919) 852-8270 (BUS) (919) 852-8282 (FAX)
		 CHATHAM COUNTY NORTH CAROLINA

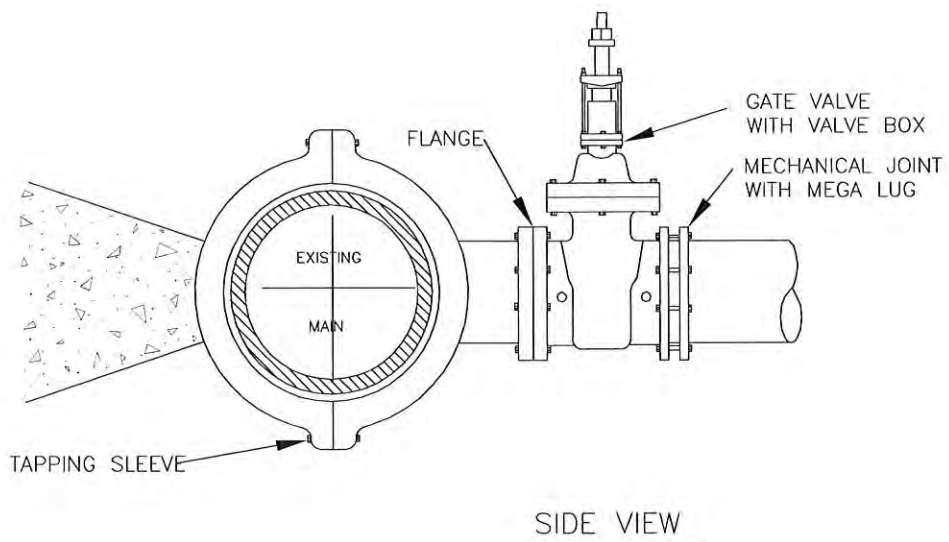
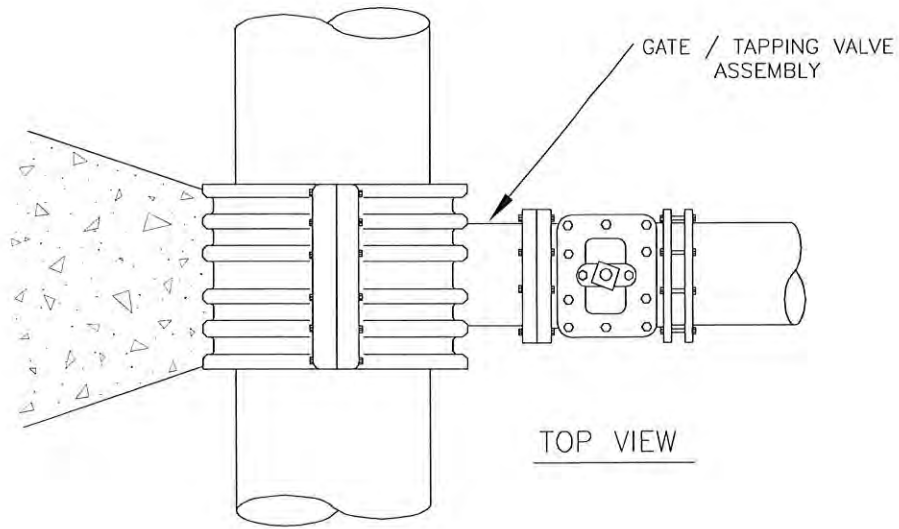

- NOTES:
1. CONCRETE SHALL NOT CONTACT BOLTS OR ENDS OF MECHANICAL JOINT FITTINGS.
 2. 3000 PSI SOLID CONCRETE SHALL BE USED AS FOOTING FOR DUCTILE IRON PIPE.
 3. SEE STANDARD REACTION BLOCK TABLES, DETAILS 38 AND 39 FOR AREA OF CONCRETE REQUIRED.

DETAIL	<h2 style="margin: 0;">4" - 24" TAPPING SLEEVE ASSEMBLY</h2>	CHATHAM COUNTY PUBLIC UTILITIES & WATER DIVISION P.O. BOX 910 PITTSBORO, NC 27312 964 EAST STREET, SUITE 205 PITTSBORO, NC 27312 (919) 852-8270 (BUS) (919) 852-8282 (FAX)	 CHATHAM COUNTY <small>NORTH CAROLINA</small>
8			
REVISION DATE			
JULY 1, 2015			

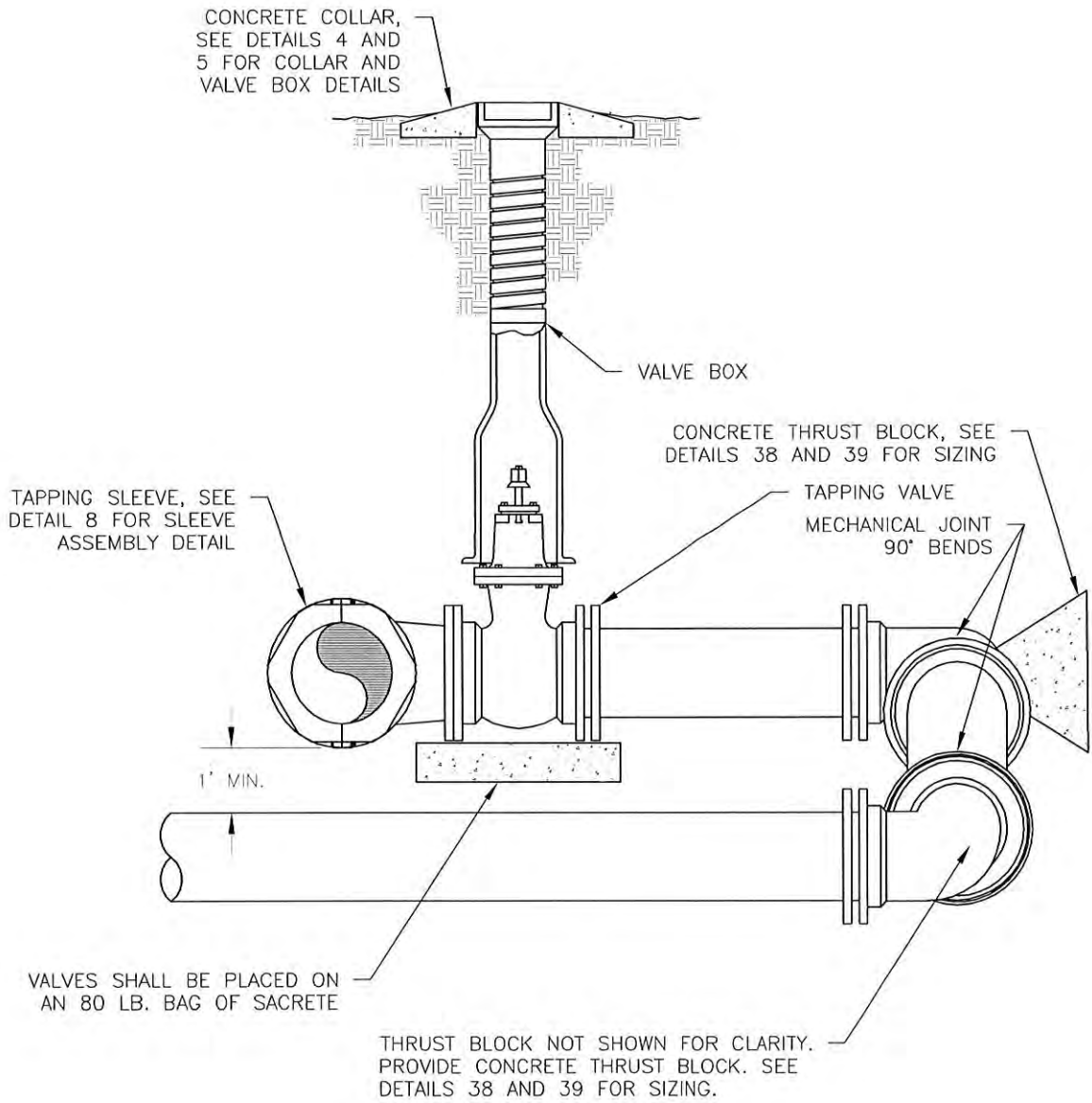

DETAIL
9
REVISION DATE
JULY 1, 2015

WRAP AROUND CONNECTION ASSEMBLY

CHATHAM COUNTY
PUBLIC UTILITIES & WATER DIVISION

P.O. BOX 910
PITTSBORO, NC 27312
964 EAST STREET, SUITE 205
PITTSBORO, NC 27312
(919) 852-8270 (BUS)
(919) 852-8282 (FAX)



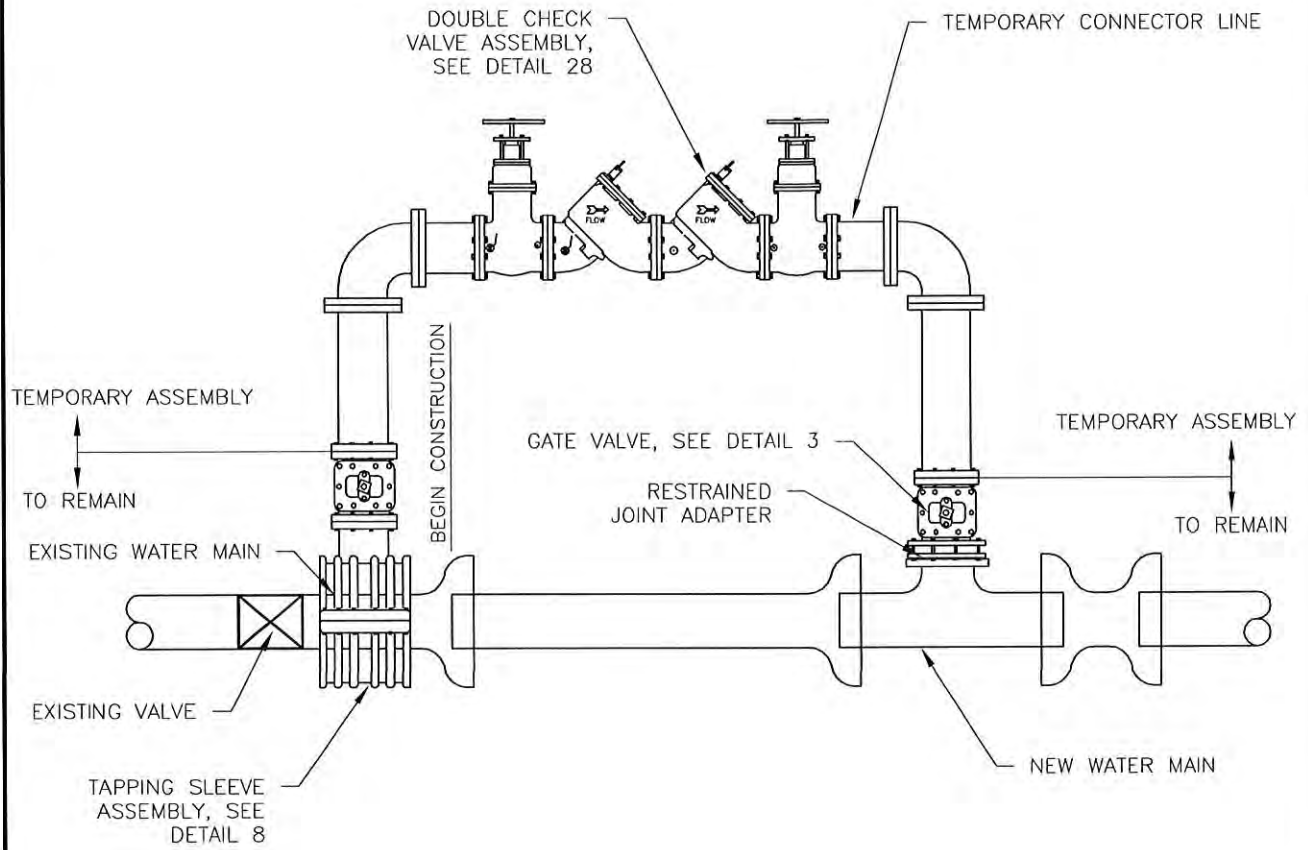

NOTES:

1. INSTALL TEMPORARY CONNECTOR LINE FROM DOWNSTREAM OF EXISTING VALVE TO NEW MAIN FOR FILLING, TESTING AND STERILIZING NEW MAIN.
2. CONNECTOR LINE TO BE ASSEMBLED WITH CHECK VALVE AND TO BE OPERATED INDEPENDENT OF EXISTING MAIN.
3. BLOCKING ON EXISTING LINE NOT TO BE DISTURBED
4. FINAL CONNECTION TO EXISTING MAIN TO BE MADE ONLY AFTER TOTAL PROJECT IS ACCEPTED BY THE WATER/UTILITIES DEPARTMENT.
5. VALVES ON EXISTING SYSTEM TO BE OPERATED BY WATER/UTILITIES DEPARTMENT FORCES ONLY.
6. ONLY ONE CONNECTION WILL BE ALLOWED BETWEEN THE EXISTING SYSTEM AND THE NEW CONSTRUCTION UNTIL TESTING AND DISINFECTION IS COMPLETE.
7. ONCE NEW MAIN IS APPROVED AND ACCEPTED BY THE WATER/UTILITIES DEPARTMENT, CLOSE BOTH GATE VALVES TO TEMPORARY CONNECTION, REMOVE TEMPORARY CONNECTION, AND SECURE BLIND FLANGES TO EXPOSED ENDS OF BOTH GATE VALVES.

DETAIL
10
REVISION DATE
JULY 1, 2015

JUMPER CONNECTION

**CHATHAM COUNTY
PUBLIC UTILITIES & WATER DIVISION**

P.O. BOX 910
PITTSBORO, NC 27312
964 EAST STREET, SUITE 205
PITTSBORO, NC 27312
(919) 852-8270 (BUS)
(919) 852-8282 (FAX)



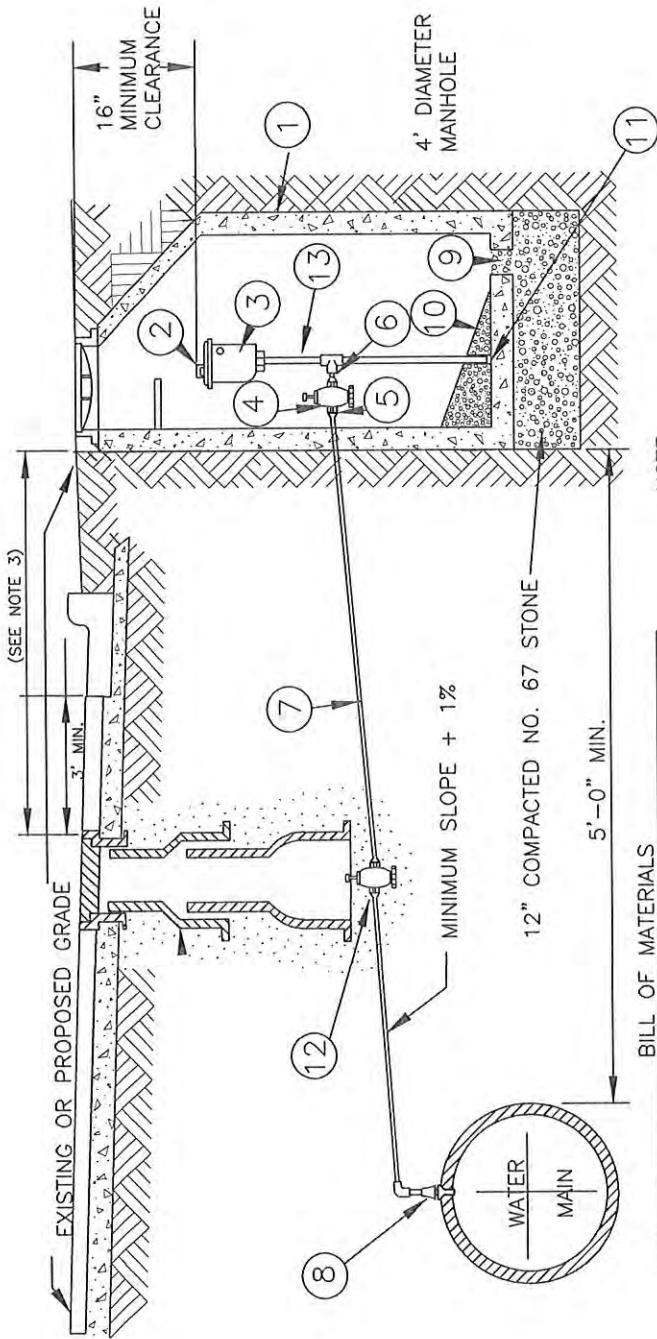

BILL OF MATERIALS

1	PRECAST MANHOLE
2	TRASH HOOD
3	2" AIR RELEASE VALVE
4	2" CURB STOP BALL VALVE
5	ADAPTER
6	2" MECHANICAL JOINT BRASS PIPE AND FITTINGS
7	2" TYPE "K", SOFT COPPER WITH FLARED ELBOW
8	CORPORATION COCK
9	6" DIAMETER DRAIN
10	GROUT, 1/8" TO 1'-0" MIN. SLOPE TO DRAIN
11	PIPE CAP
12	2"-GATE VALVE
13	2" TYPE "K", SOFT COPPER PIPE

NOTE:

- AIR VALVE TO BE CRISPIN (UL20), ARI (D-050), APCO (200A), OR CLA-VAL (33A).
- THE AIR RELEASE MANHOLE SHALL BE INSTALLED IN THE SHOULDER OR AS DIRECTED BY THE ENGINEER.
- FOR MAINS LOCATED OUTSIDE OF STREET RIGHT-OF-WAYS THE MAXIMUM DISTANCE BETWEEN THE MANHOLE AND THE VALVE BOX SHOULD BE THREE (3) FEET.
- MAIN SHALL BE DEEP ENOUGH TO ACCOMMODATE INSTALLATION AS SHOWN
- MINIMUM 300 PSI CONCRETE, H-20 LOAD RATED, USE A BUTYL SEALANT BETWEEN FRAME AND MANHOLE TOP SECTION WHEN SECURING FRAME TO MANHOLE TO PROVIDE A WATER TIGHT SEAL, COVER SHALL BE DOMESTICALLY CAST WITH A MINIMUM WEIGHT OF 125 POUNDS, FRAME SHALL BE A MINIMUM OF 182 POUNDS WITH A CLEAR OPENING DIAMETER OF AT LEAST 22 INCHES.

SEE STANDARD DETAIL 35 TO INSURE PROPER BACKFILL.

DETAIL

11

REVISION
DATE

FEB. 23, 2016

STANDARD WATER AIR RELEASE VALVE

CHATHAM COUNTY
PUBLIC UTILITIES & WATER DIVISION

P.O. BOX 910
PITTSBORO, NC 27312
964 EAST STREET, SUITE 205
PITTSBORO, NC 27312

(919) 852-8270 (BUS)
(919) 852-8282 (FAX)



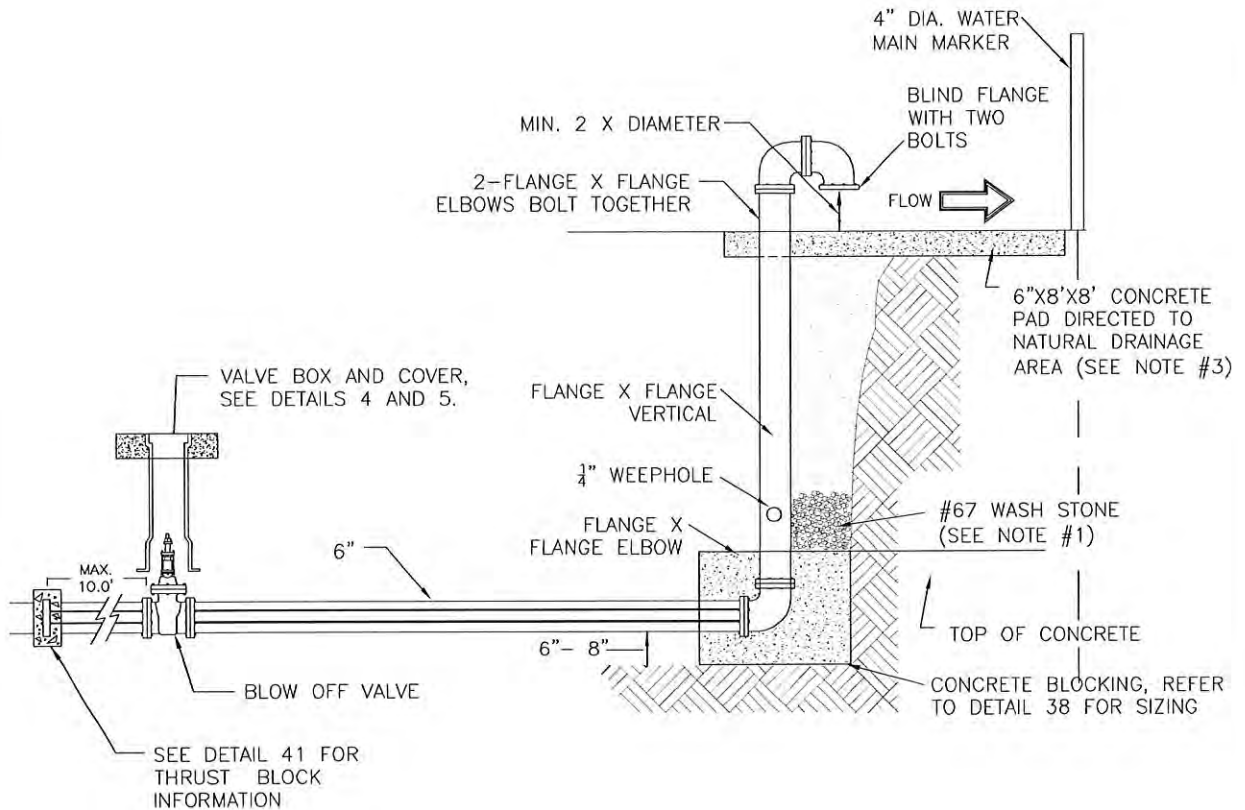



NOTES:

1. DRILL 1/4" WEEP HOLE FOR STACK DRAINAGE INTO STONE.
2. DOUBLE 3/4" BRIDLE RODS ON BOTH SIDES.
3. A RIP-RAP SWALE FROM FROM CONCRETE SPLASH PAD TO POSITIVE DRAINAGE AREA IS REQUIRED.
4. BOTTOM 90° ELBOW SHALL HAVE BLIND FLANGE ATTACHED WITH TWO BOLTS.
5. INSTALL WATER MAIN MARKER AT R/W OR P/L TO LOCATE MAIN.
6. 3/4" RODS AND BOLTS TO BE HOT DIPPED GALVANIZED.
7. END PIPE SIZE 6" MIN. OR AS APPROVED BY WATER/UTILITIES DEPARTMENT.

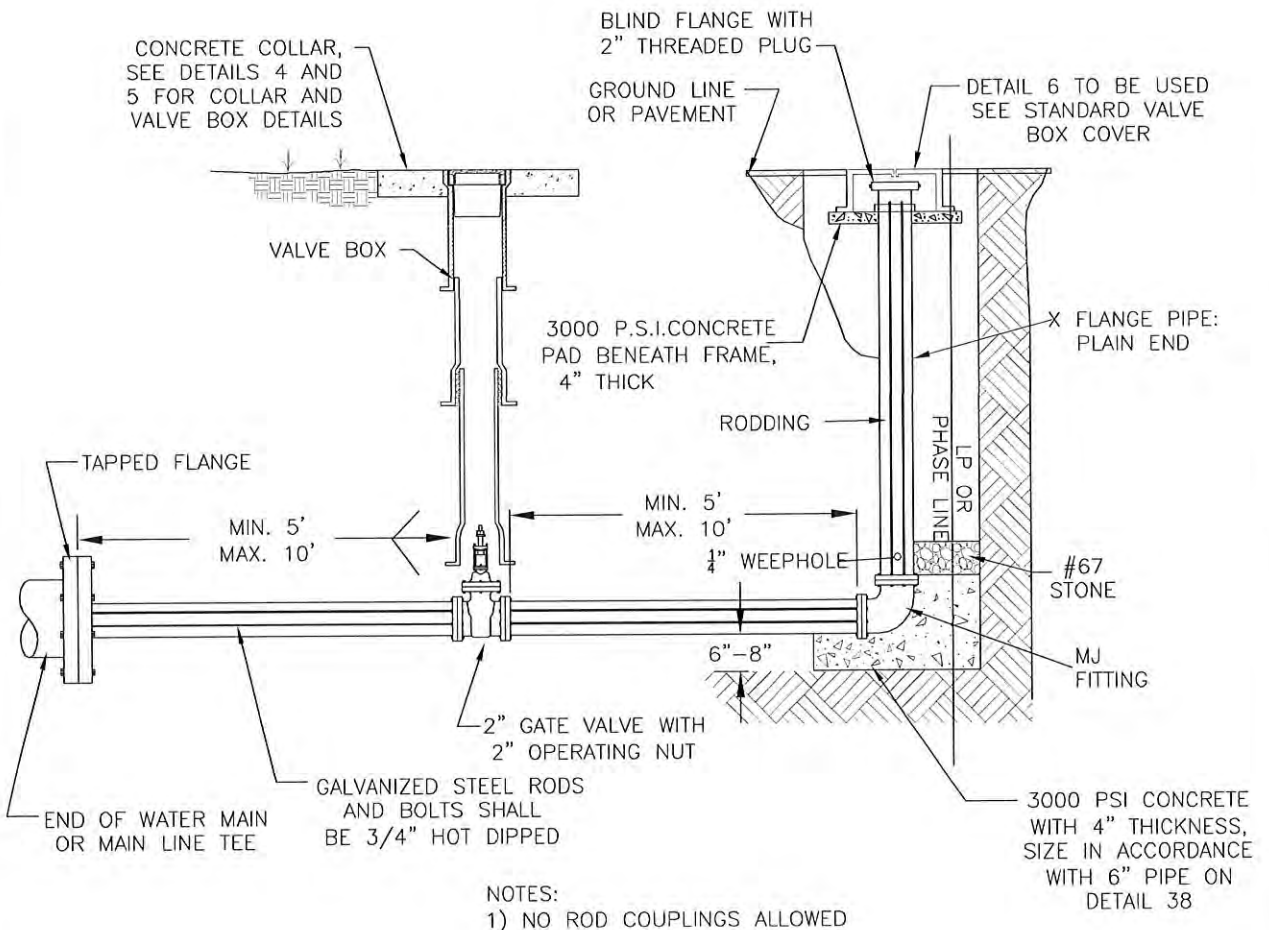
DETAIL	<h2>PERMANENT WATER MAIN BLOW-OFF ASSEMBLY</h2>	CHATHAM COUNTY PUBLIC UTILITIES & WATER DIVISION	
12		P.O. BOX 910 PITTSBORO, NC 27312	
REVISION DATE		964 EAST STREET, SUITE 205 PITTSBORO, NC 27312	
JULY 1, 2015		(919) 852-8270 (BUS) (919) 852-8282 (FAX)	



DETAIL	<h2>2" BLOW-OFF ASSEMBLY AT END OF WATER MAIN</h2>	<p>CHATHAM COUNTY PUBLIC UTILITIES & WATER DIVISION</p> <p>P.O. BOX 910 PITTSBORO, NC 27312</p> <p>964 EAST STREET, SUITE 205 PITTSBORO, NC 27312</p> <p>(919) 852-8270 (BUS) (919) 852-8282 (FAX)</p>	
13			
REVISION DATE			
JULY 1, 2015			

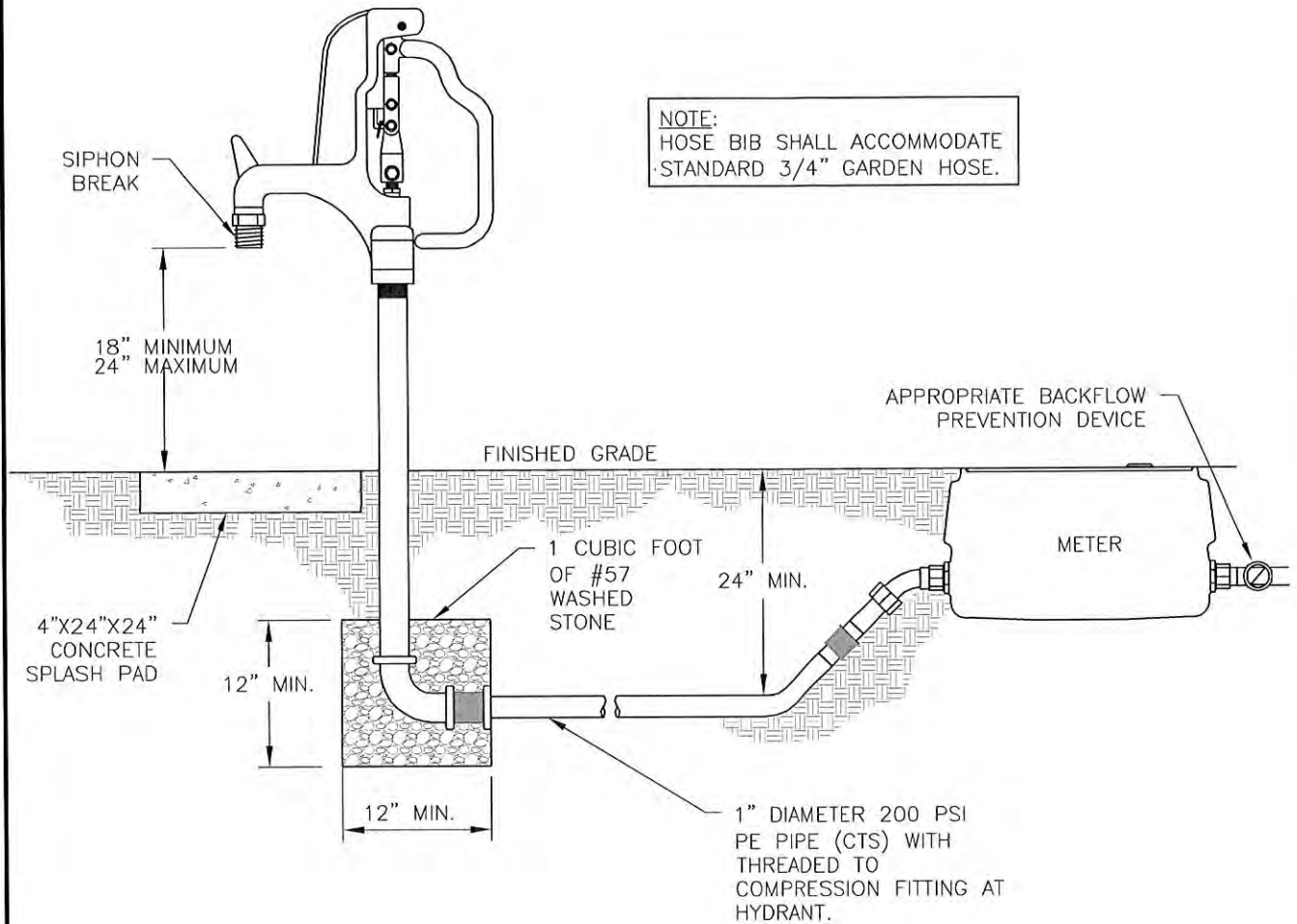

DETAIL	<h1>YARD HYDRANT</h1>	CHATHAM COUNTY PUBLIC UTILITIES & WATER DIVISION	
<h1>15</h1>		P.O. BOX 910 PITTSBORO, NC 27312	
REVISION DATE		964 EAST STREET, SUITE 205 PITTSBORO, NC 27312	
JULY 1, 2015		(919) 852-8270 (BUS) (919) 852-8282 (FAX)	
		 CHATHAM COUNTY NORTH CAROLINA	

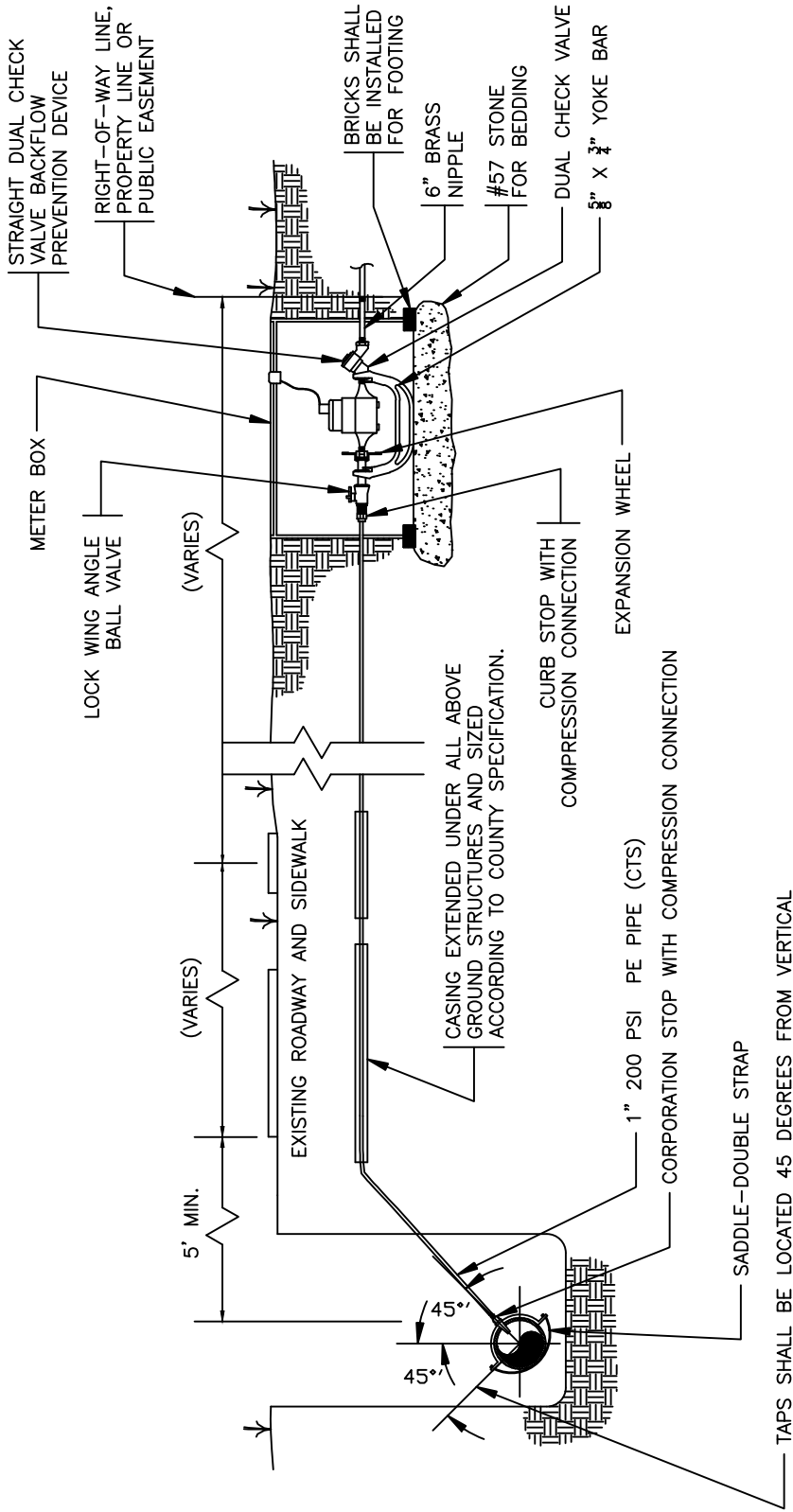

NOTES:

1. METERS SHALL BE 5/8"x3/4" OR 1" BADGER WATER METER WITH ADE ENCODER (1,000 GALLON RESOLUTION) AND ITRON 100W ENDPOINT.
2. METER BOX TO BE LOCATED IN RIGHT-OF-WAY ADJACENT TO PROPERTY LINE OR IN APPROVED EASEMENT ADJACENT TO RIGHT-OF-WAY.
3. WHEN THE GRADE CHANGES, A COPPER RESETTER CAN BE USED TO ADJUST TO PROPER GRADE.

DETAIL
16
REVISION DATE: NOVEMBER 16, 2015

**5/8" X 3/4" - 1" METER
SERVICE CONNECTION**

**CHATHAM COUNTY
PUBLIC UTILITIES & WATER DIVISION**

P.O. BOX 910
PITTSBORO, NC 27312

964 EAST STREET, SUITE 205
PITTSBORO, NC 27312

(919) 852-8270 (BUS)
(919) 852-8282 (FAX)



CHATHAM COUNTY
NORTH CAROLINA

IRON READER SHALL BE COATED
WITH BLACK BITUMINOUS FINISH

WEIGHT:
COVER - 2½ LBS
BODY - 7½ LBS

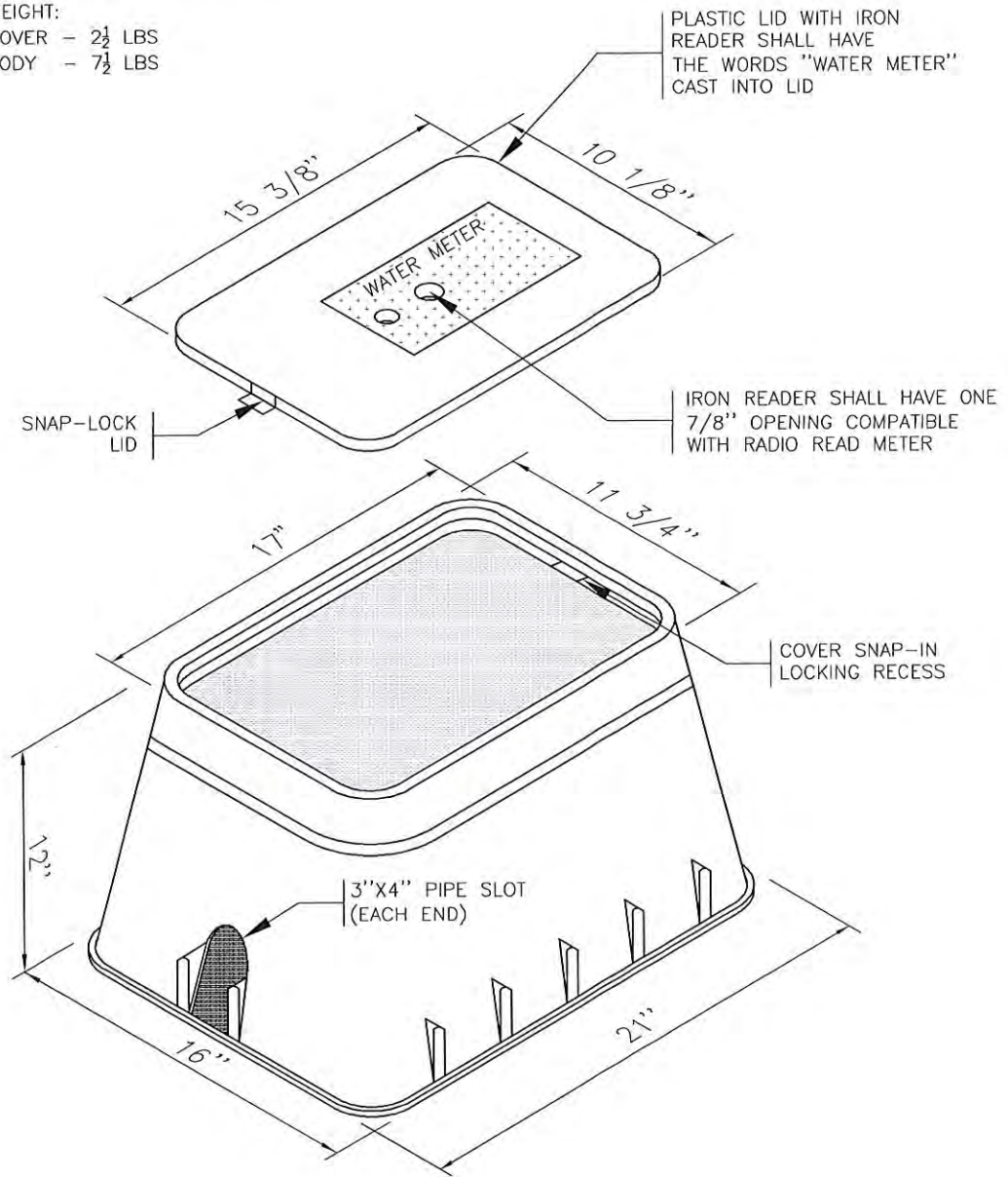

DETAIL	<h1>WATER METER BOX</h1>	CHATHAM COUNTY PUBLIC UTILITIES & WATER DIVISION	 CHATHAM COUNTY NORTH CAROLINA
17		P.O. BOX 910 PITTSBORO, NC 27312	
REVISION DATE		964 EAST STREET, SUITE 205 PITTSBORO, NC 27312	
JULY 1, 2015		(919) 852-8270 (BUS) (919) 852-8282 (FAX)	

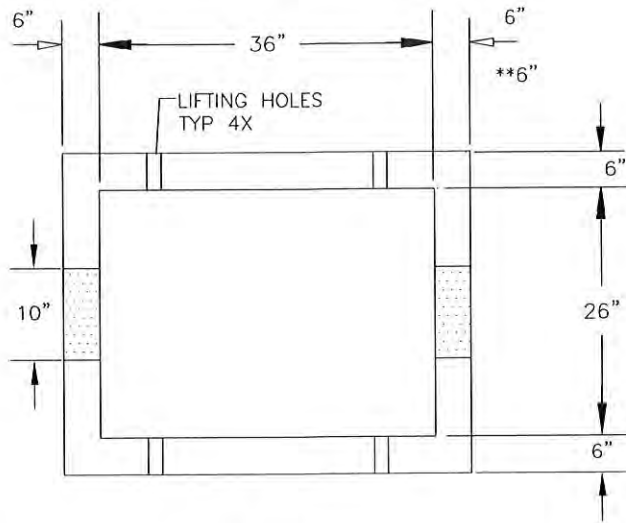

VALVE BOX AND COVER, SEE DETAILS 4 AND 5

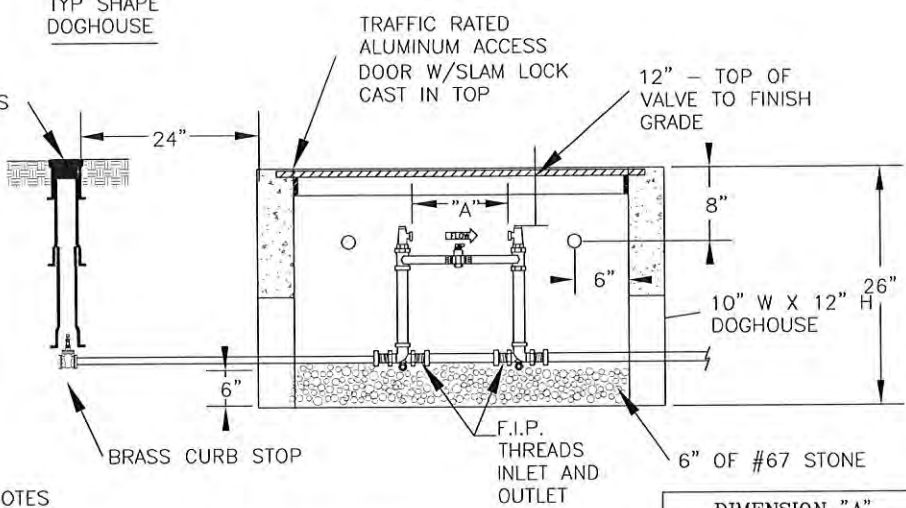

NOTES

1. METER AS MANUFACTURED BY BADGER
2. BACKFILL TAMPED IN 6" LIFTS.
3. REINFORCEMENT: #4 @ 6" OCEW
4. CONCRETE: 4,000 PSI @ 28 DAYS
5. ALL RPZ BACKFLOW PREVENTION DEVICES MUST BE INSTALLED PRIOR TO METER BEING SET.
6. ALL COPPER SETTERS ARE TO HAVE A BALL TYPE SHUT OFF VALVE ON BOTH SIDES OF COPPER SETTER WITH HIGH RISE BYPASS THAT IS MANUFACTURED BY FORD OR MUELLER (NO EXCEPTIONS).

DIMENSION "A"	
1 1/2" METER	13 1/4"
2" METER	17 1/2"

** TRAFFIC RATED VAULT WALL THICKNESS

DETAIL
18
REVISION DATE
JULY 1, 2015

1 1/2" - 2" METER SERVICE CONNECTION

**CHATHAM COUNTY
PUBLIC UTILITIES & WATER DIVISION**

P.O. BOX 910
PITTSBORO, NC 27312
964 EAST STREET, SUITE 205
PITTSBORO, NC 27312
(919) 852-8270 (BUS)
(919) 852-8282 (FAX)



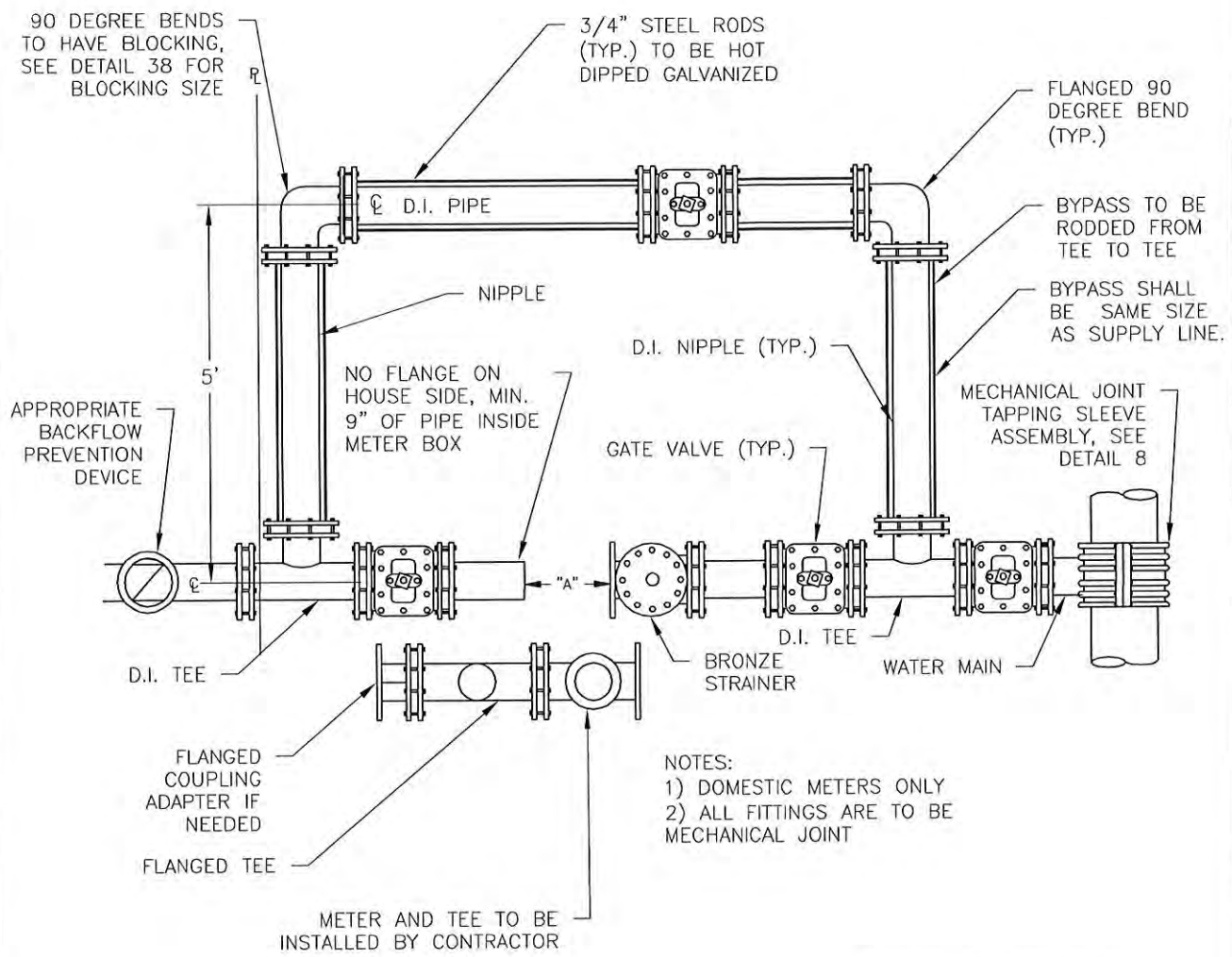

NOTES:
 1) DOMESTIC METERS ONLY
 2) ALL FITTINGS ARE TO BE MECHANICAL JOINT

"A" METER OPENING	
4" METER	28"
6" METER	35"
8" METER	39"

DETAIL	<h2>4" - 8" DOMESTIC METER WITH BYPASS</h2>	CHATHAM COUNTY PUBLIC UTILITIES & WATER DIVISION
19		P.O. BOX 910 PITTSBORO, NC 27312
REVISION DATE		964 EAST STREET, SUITE 205 PITTSBORO, NC 27312
JULY 1, 2015		(919) 852-8270 (BUS) (919) 852-8282 (FAX)



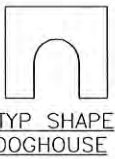
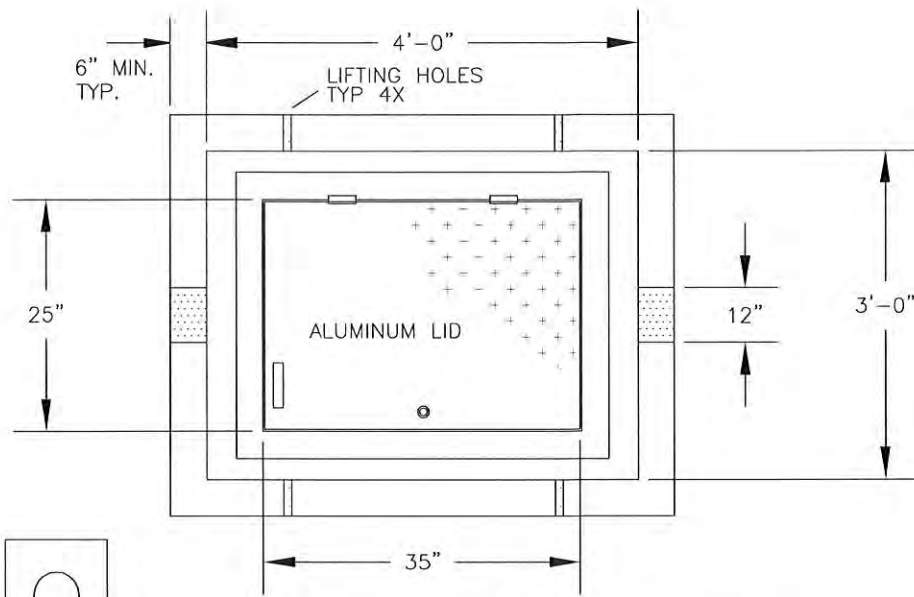

TYP SHAPE DOGHOUSE

12"W x 18"H DOGHOUSE

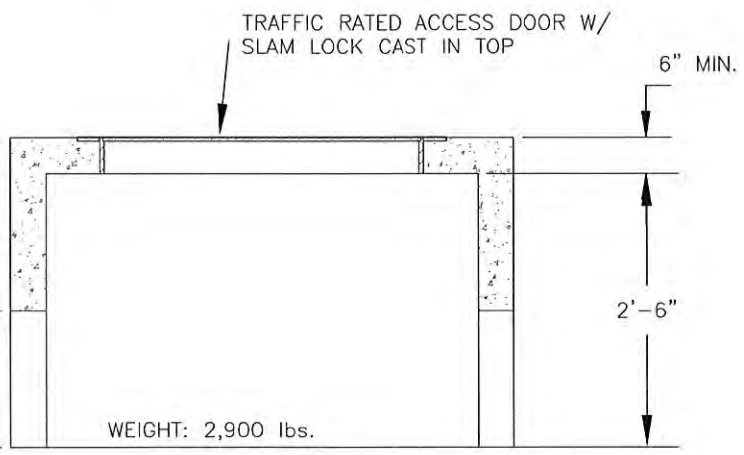

- NOTES:
- 1) REINFORCEMENT: #4 @ 6" OCEW
 - 2) CONCRETE: 4,000 PSI @ 28 DAYS
 - 3) 6" OF #67 STONE SHALL BE PLACED IN BOTTOM OF VAULT
 - 4) METER FLANGE SHALL BE PLACED 42 " BELOW FINISHED GRADE

DETAIL	<h1>4" METER VAULT</h1>	<p>CHATHAM COUNTY PUBLIC UTILITIES & WATER DIVISION</p> <p>P.O. BOX 910 PITTSBORO, NC 27312</p> <p>964 EAST STREET, SUITE 205 PITTSBORO, NC 27312</p> <p>(919) 852-8270 (BUS) (919) 852-8282 (FAX)</p> 
20		
REVISION DATE		
JULY 1, 2015		

90 DEGREE BENDS TO HAVE
BLOCKING, SEE DETAIL 38
FOR BLOCKING SIZE

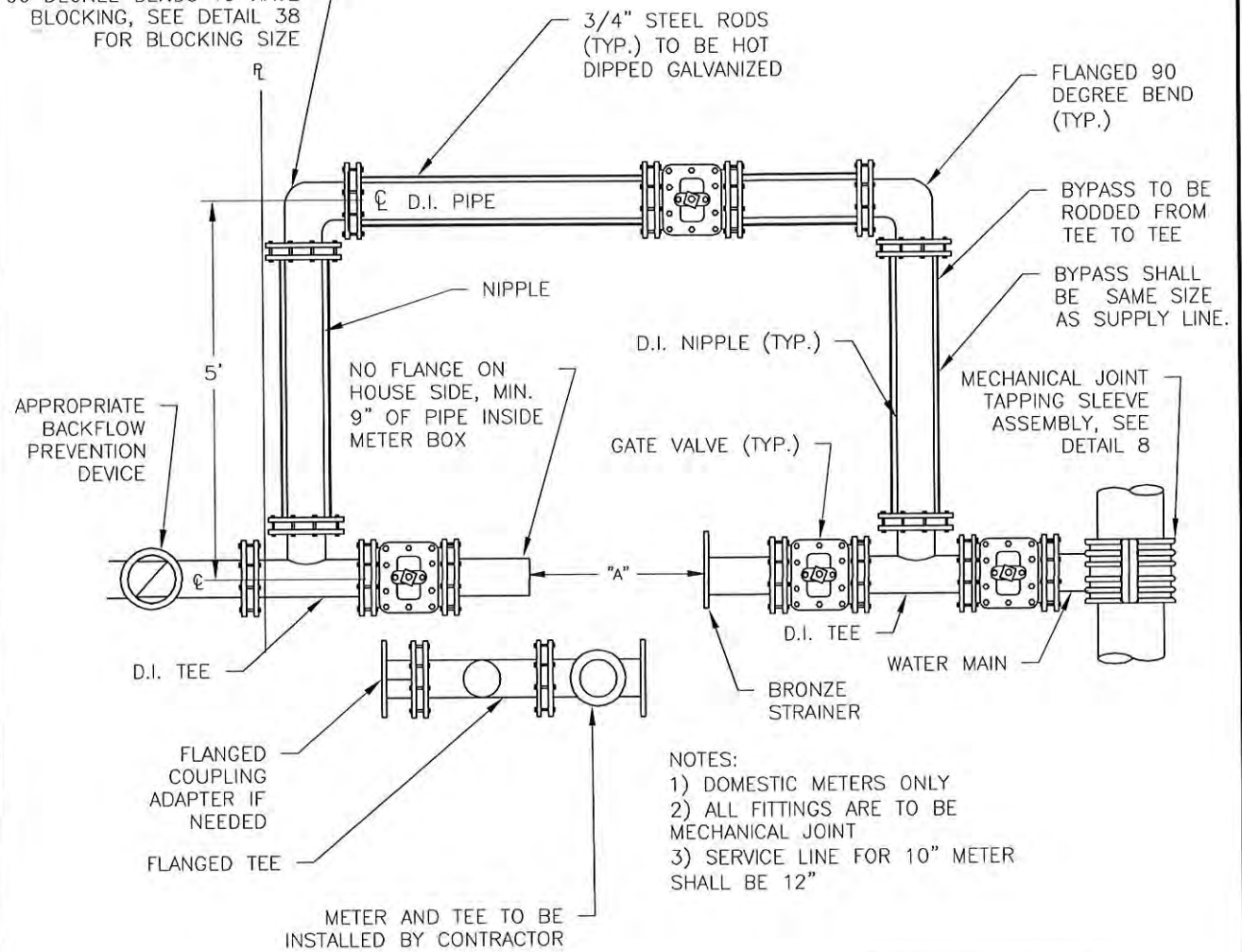

- NOTES:
 1) DOMESTIC METERS ONLY
 2) ALL FITTINGS ARE TO BE MECHANICAL JOINT
 3) SERVICE LINE FOR 10" METER SHALL BE 12"

"A" METER OPENING	
6" METER	46"
8" METER	54"
10" METER	69"

DETAIL
21
REVISION DATE
JULY 1, 2015

6" - 10" FIRE AND DOMESTIC METER SERVICE WITH BYPASS

**CHATHAM COUNTY
PUBLIC UTILITIES & WATER DIVISION**

P.O. BOX 910
PITTSBORO, NC 27312

964 EAST STREET, SUITE 205
PITTSBORO, NC 27312

(919) 852-8270 (BUS)
(919) 852-8282 (FAX)



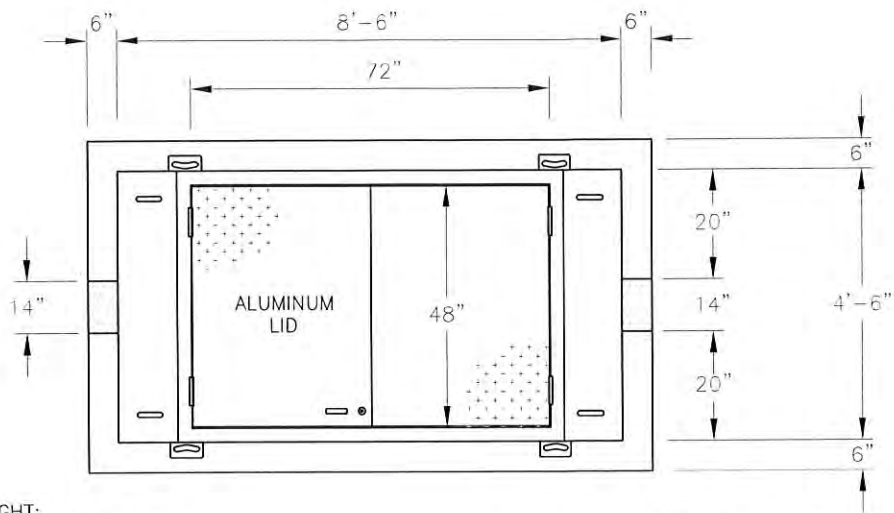

WEIGHT:
 TOP: 10,600 LBS
 BOTTOM: 8,700 LBS

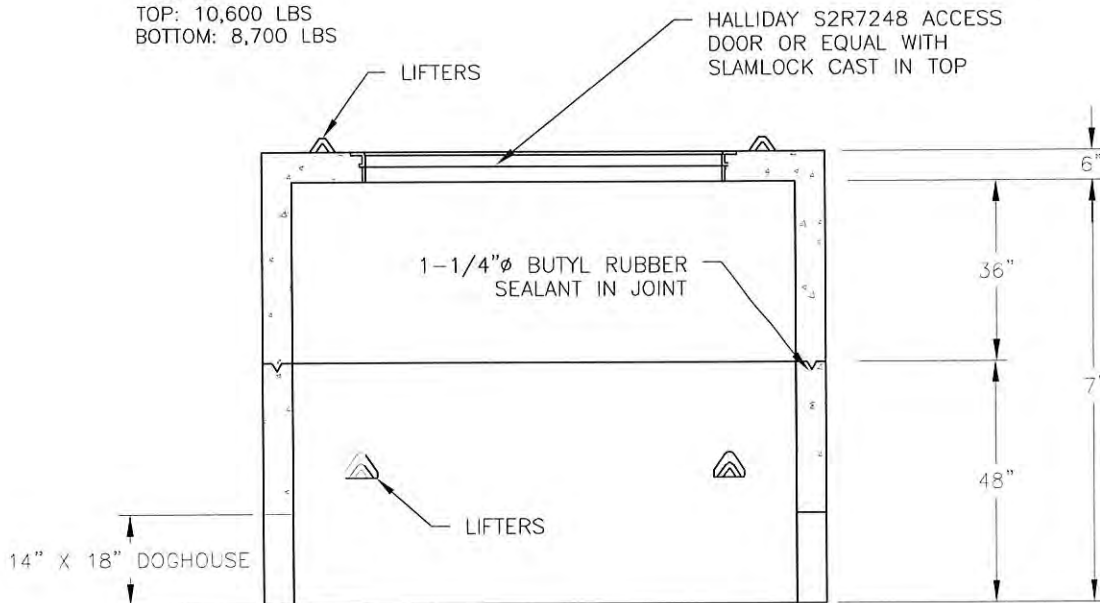

NOTES:

1. REINFORCEMENT: #4 @ 6" OCEW
2. CONCRETE: 4,000 PSI @ 28 DAYS
3. 6" OF #67 STONE SHALL BE PLACED IN BOTTOM OF VAULT
4. METER FLANGE SHALL BE PLACED 49" BELOW FINISHED GRADE

DETAIL	<h2>6" - 10" METER VAULT</h2>	CHATHAM COUNTY PUBLIC UTILITIES & WATER DIVISION
22		P.O. BOX 910 PITTSBORO, NC 27312
REVISION DATE		964 EAST STREET, SUITE 205 PITTSBORO, NC 27312
JULY 1, 2015		(919) 852-8270 (BUS) (919) 852-8282 (FAX)
		

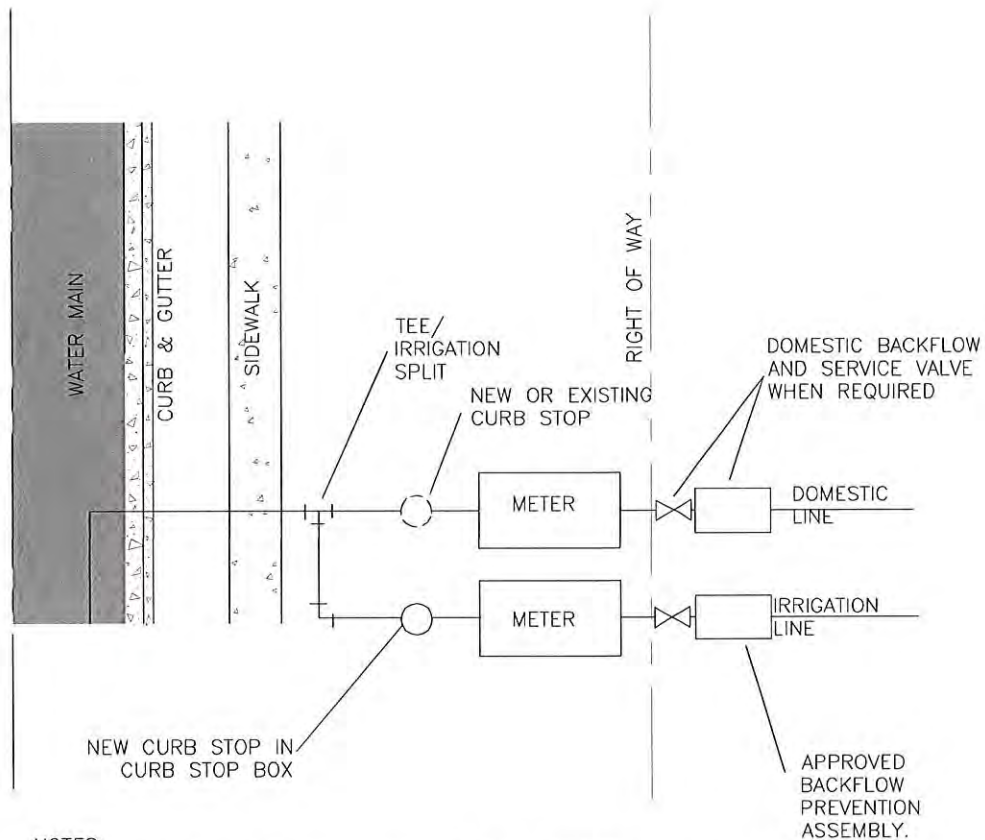

NOTES:

1. IRRIGATION METER SHALL BE LOCATED ON THE SIDE OF DOMESTIC METER WITH INCREASING ADDRESSES.
2. THE BACKFLOW SHALL BE INSTALLED NO MORE THAN 10' FROM THE METER IN A VISIBLE LOCATION.
3. BACKFLOW RISER/STANDPIPE SHALL BE OF COPPER OR BRASS.
4. A SERVICE VALVE IS REQUIRED AFTER THE METER BUT BEFORE THE BACKFLOW ASSEMBLY FOR MAINTENANCE AND REPLACEMENT PURPOSES.
5. THE INSTALLATION MUST ALSO MEET ALL CODE REQUIREMENTS PER THE NC PLUMBING CODE.

DETAIL	<h2 style="margin: 0;">IRRIGATION TAP ON NEW AND EXISTING SERVICES</h2>	CHATHAM COUNTY PUBLIC UTILITIES & WATER DIVISION	
23		P.O. BOX 910 PITTSBORO, NC 27312	
REVISION DATE		964 EAST STREET, SUITE 205 PITTSBORO, NC 27312 (919) 852-8270 (BUS) (919) 852-8282 (FAX)	
JULY 1, 2015			

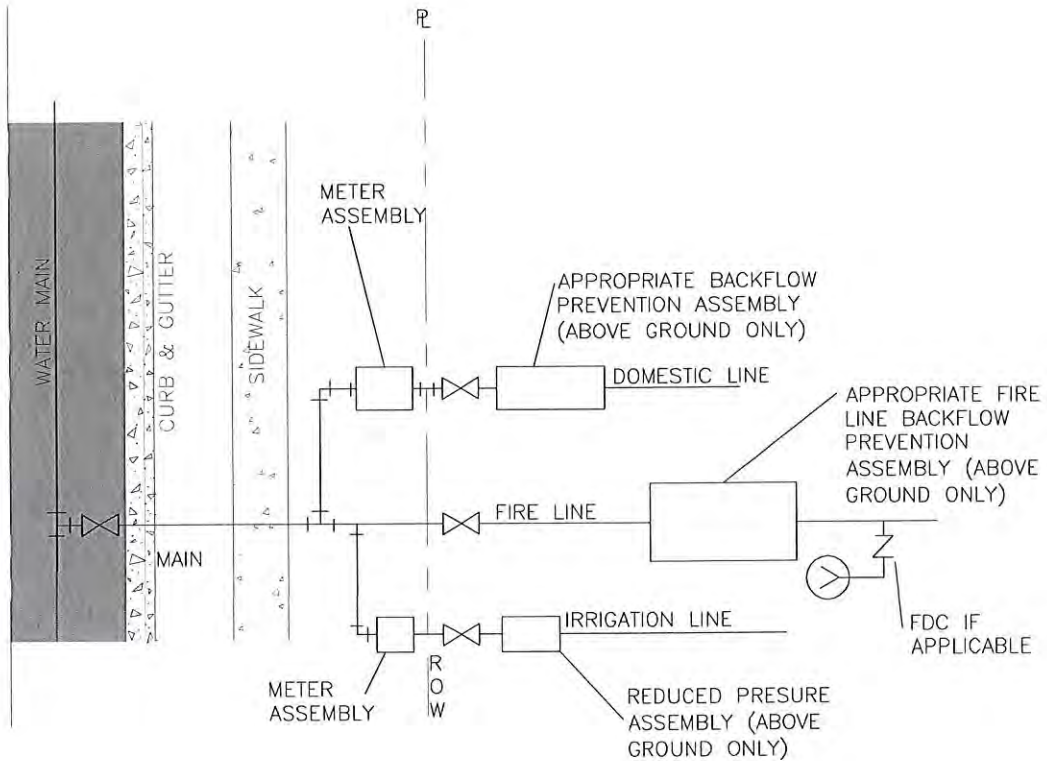

1. SERVICE TAPS FOR 2" AND SMALLER DOMESTIC SERVICES MAY BE BY CORPORATION COCKS. LARGER SERVICES WILL REQUIRE A TEE AND GATE VALVE OR TAPPING SLEEVE AND VALVE ASSEMBLY, SEE DETAIL 8, AND 90° BEND.
2. DOMESTIC SERVICE TAPS SHALL BE ALLOWED ONLY ON 6" OR LARGER FIRE LINES BEFORE THE BACKFLOW ASSEMBLY.
3. ONE DOMESTIC TAP PER FIRE LINE ON STREET SIDE OF BACKFLOW.
4. FIRE LINE SHALL HAVE A FIRE HYDRANT OR BLOW OFF ASSEMBLY AT ITS END TO FACILITATE FLUSHING WHEN NEEDED.
5. IRRIGATION METER SHALL BE LOCATED ON THE SIDE OF DOMESTIC METER WITH INCREASING ADDRESSES.
6. THE BACKFLOW SHALL BE INSTALLED NO MORE THAN 10' FROM THE METER IN A VISIBLE LOCATION.
7. DOMESTIC/IRRIGATION BACKFLOW RISER/STANDPIPE SHALL BE OF COPPER OR BRASS.
8. A SERVICE VALVE IS REQUIRED AFTER THE METER BUT BEFORE THE BACKFLOW ASSEMBLY FOR MAINTENANCE AND REPLACEMENT PURPOSES.
9. THE INSTALLATION MUST ALSO MEET ALL CODE REQUIREMENTS PER THE NC PLUMBING CODE.

DETAIL	<h2 style="margin: 0;">FIRE, DOMESTIC & IRRIGATION OPTIONS SCHEMATIC</h2>	CHATHAM COUNTY PUBLIC UTILITIES & WATER DIVISION	
24		P.O. BOX 910 PITTSBORO, NC 27312	
REVISION DATE		964 EAST STREET, SUITE 205 PITTSBORO, NC 27312 (919) 852-8270 (BUS) (919) 852-8282 (FAX)	
JULY 1, 2015			

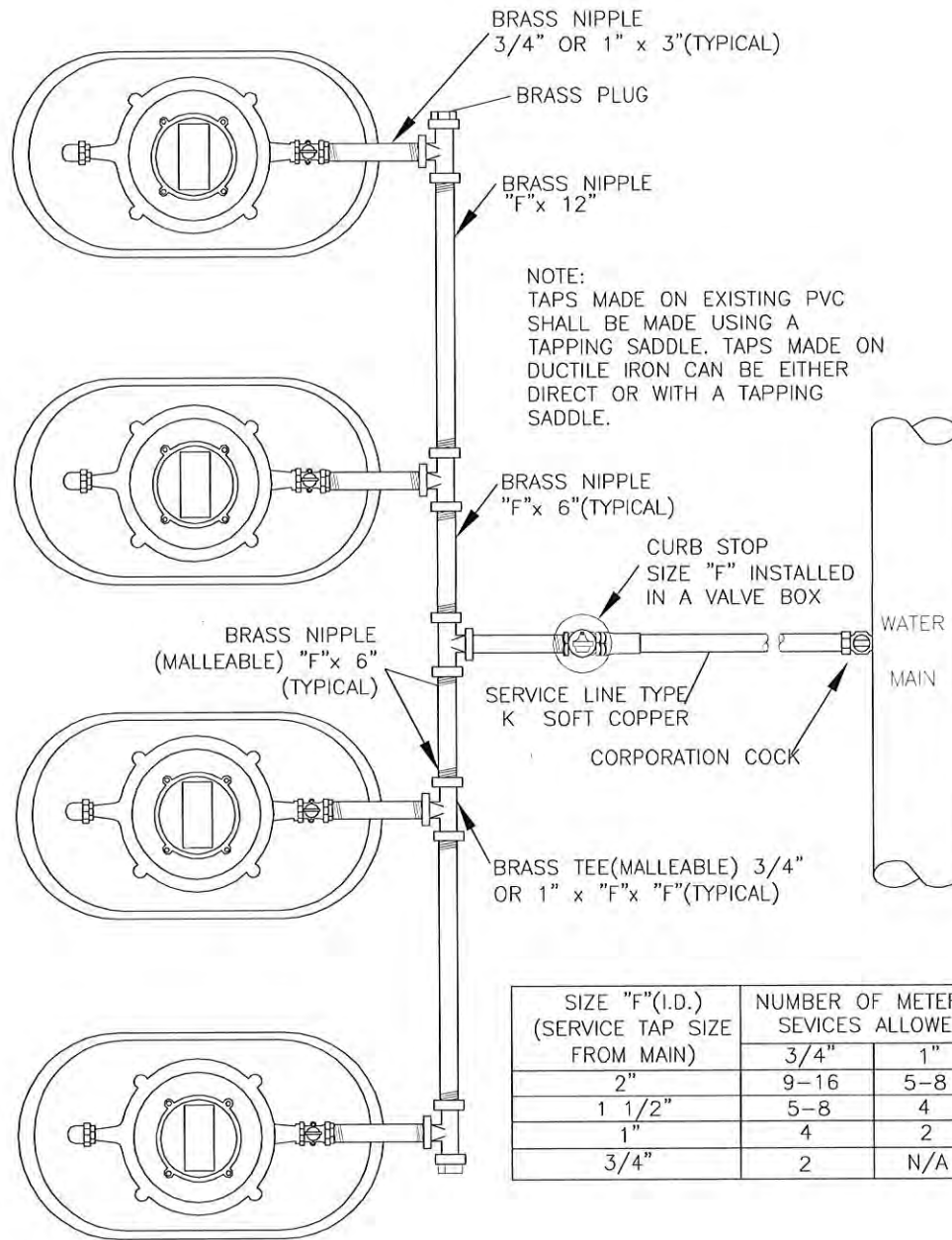

DETAIL	<h1>GANG METER ASSEMBLY</h1>	<p>CHATHAM COUNTY PUBLIC UTILITIES & WATER DIVISION</p> <p>P.O. BOX 910 PITTSBORO, NC 27312</p> <p>964 EAST STREET, SUITE 205 PITTSBORO, NC 27312</p> <p>(919) 852-8270 (BUS) (919) 852-8282 (FAX)</p> 
<h2>25</h2>		
REVISION DATE		
JULY 1, 2015		

ODD NUMBERED ADDRESS

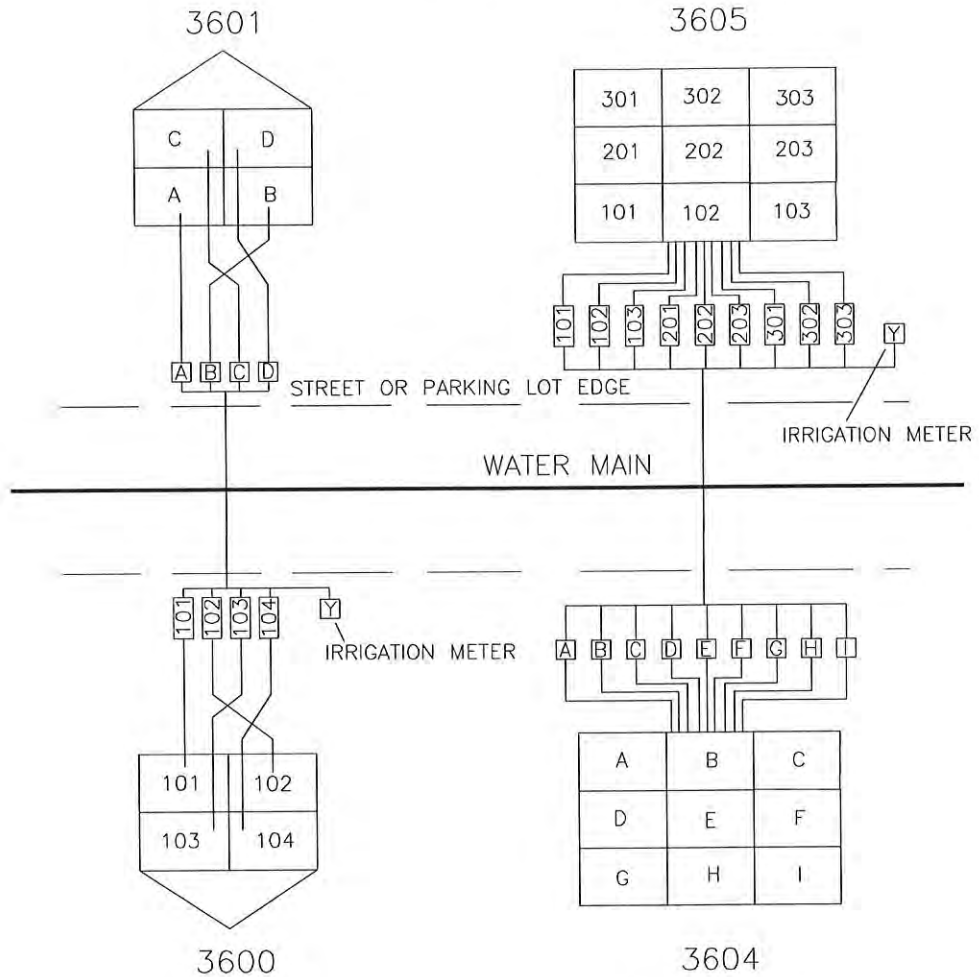

EVEN NUMBERED ADDRESS

NOTES:

1. EVEN NUMBERED UNITS' METERS SHALL BE SET TO BE READ RIGHT TO LEFT (WHEN FACING BUILDING)
2. ODD NUMBERED UNITS' METERS SHALL BE SET TO BE READ LEFT TO RIGHT (WHEN FACING BUILDING)
3. IF IRRIGATION METER IS INCLUDED, IT SHALL BE THE LAST METER IN NUMBERING SEQUENCE.
4. UNIT 'Y' (FOR YARD METER) SHALL BE USED TO INDICATE IRRIGATION METER.

DETAIL	<h2 style="margin: 0;">GANG METER ADDRESSING MULTI-STORY BUILDING</h2>	<p>CHATHAM COUNTY PUBLIC UTILITIES & WATER DIVISION</p> <p>P. O. BOX 910 PITTSBORO, NC 27312</p> <p>964 EAST STREET, SUITE 205 PITTSBORO, NC 27312</p> <p>(919) 852-8270 (BUS) (919) 852-8282 (FAX)</p>	
26			
REVISION DATE			
JULY 1, 2015			

ODD NUMBERED ADDRESS

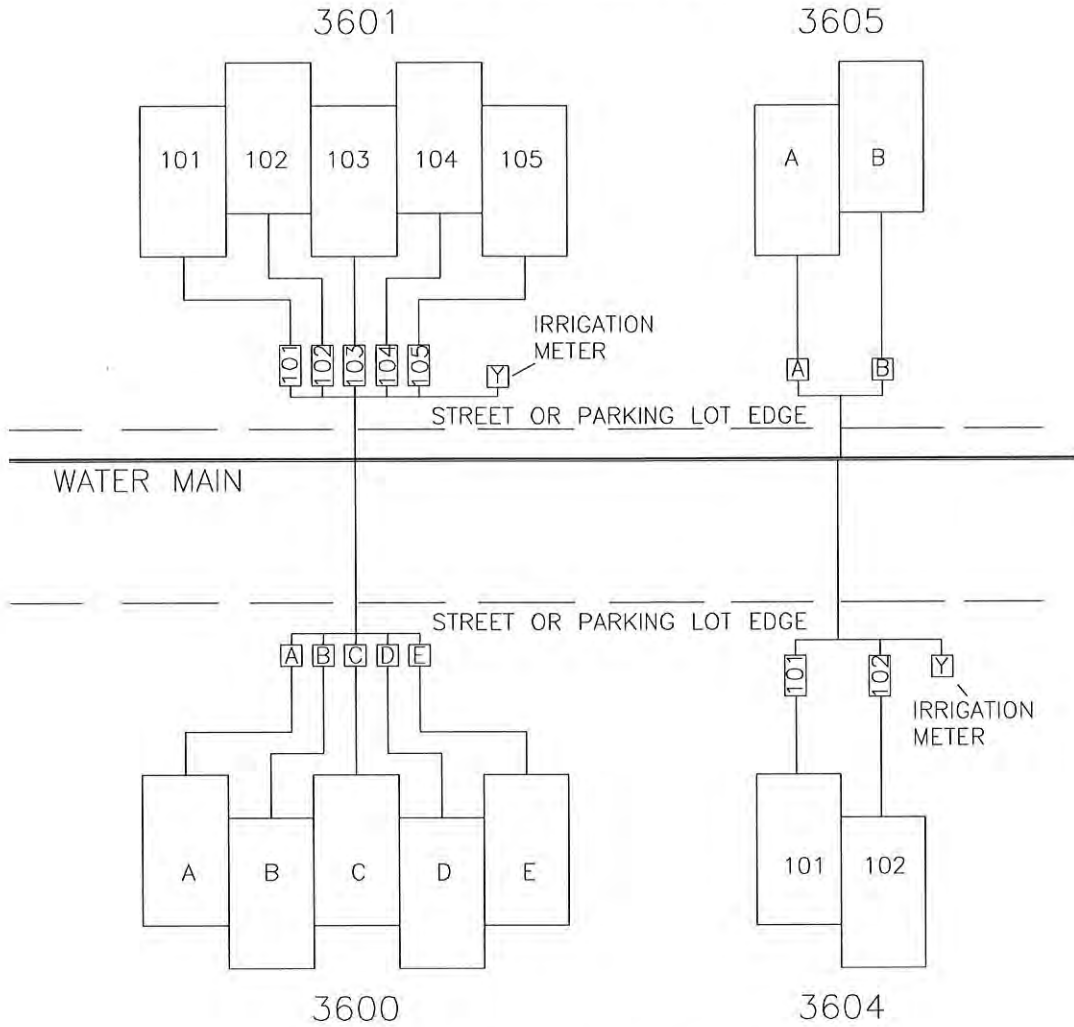

EVEN NUMBERED ADDRESS

NOTES:

1. EVEN NUMBERED UNITS' METERS SHALL BE SET TO BE READ RIGHT TO LEFT (WHEN FACING BUILDING)
2. ODD NUMBERED UNITS' METERS SHALL BE SET TO BE READ LEFT TO RIGHT (WHEN FACING BUILDING)
3. IF IRRIGATION METER IS INCLUDED, IT SHALL BE THE LAST METER IN NUMBERING SEQUENCE.
4. UNIT 'Y' (FOR YARD METER) SHALL BE USED TO INDICATE IRRIGATION METER.

DETAIL	<h2 style="margin: 0;">GANG METER ADDRESSING SINGLE STORY BUILDING</h2>	<p>CHATHAM COUNTY PUBLIC UTILITIES & WATER DIVISION</p> <p>P.O. BOX 910 PITTSBORO, NC 27312</p> <p>964 EAST STREET, SUITE 205 PITTSBORO, NC 27312</p> <p>(919) 852-8270 (BUS) (919) 852-8282 (FAX)</p>	
27			
REVISION DATE			
JULY 1, 2015			

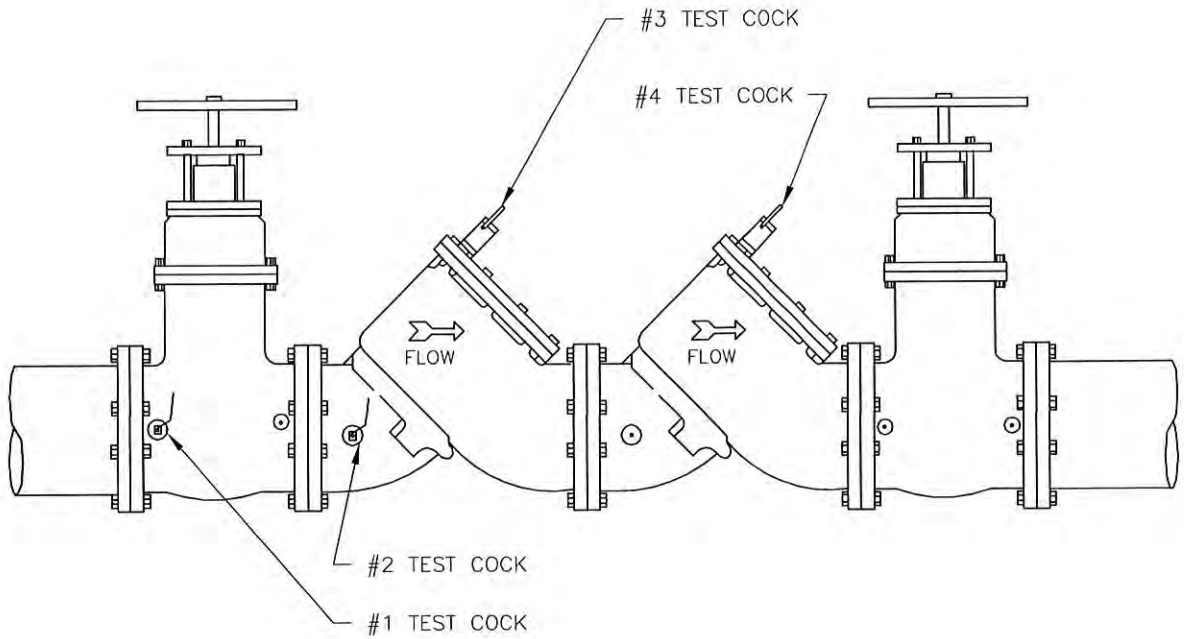

NOTES:

1. SHUT-OFF VALVES, CHECK VALVES AND TEST COCKS SHALL BE STANDARD TO THE APPROVED BACKFLOW ASSEMBLY.
2. ALL ASSEMBLIES TO BE SUPPORTED BY A CRADLE.
3. ENCLOSURE FOUNDATIONS SHALL BE CONSTRUCTED OF 4" OF CONCRETE OR 6" OF STONE.
4. ASSEMBLIES MUST BE ON CURRENT APPROVAL LIST.
5. 2 1/2" AND LARGER ASSEMBLIES SHALL BE FUSION BONDED EPOXY COATED INCLUDING SHUTOFF VALVES.

DETAIL	<h2>DOUBLE CHECK VALVE ASSEMBLY</h2>	CHATHAM COUNTY PUBLIC UTILITIES & WATER DIVISION	 CHATHAM COUNTY NORTH CAROLINA
28		P.O. BOX 910 PITTSBORO, NC 27312	
REVISION DATE		964 EAST STREET, SUITE 205 PITTSBORO, NC 27312	
JULY 1, 2015		(919) 852-8270 (BUS) (919) 852-8282 (FAX)	

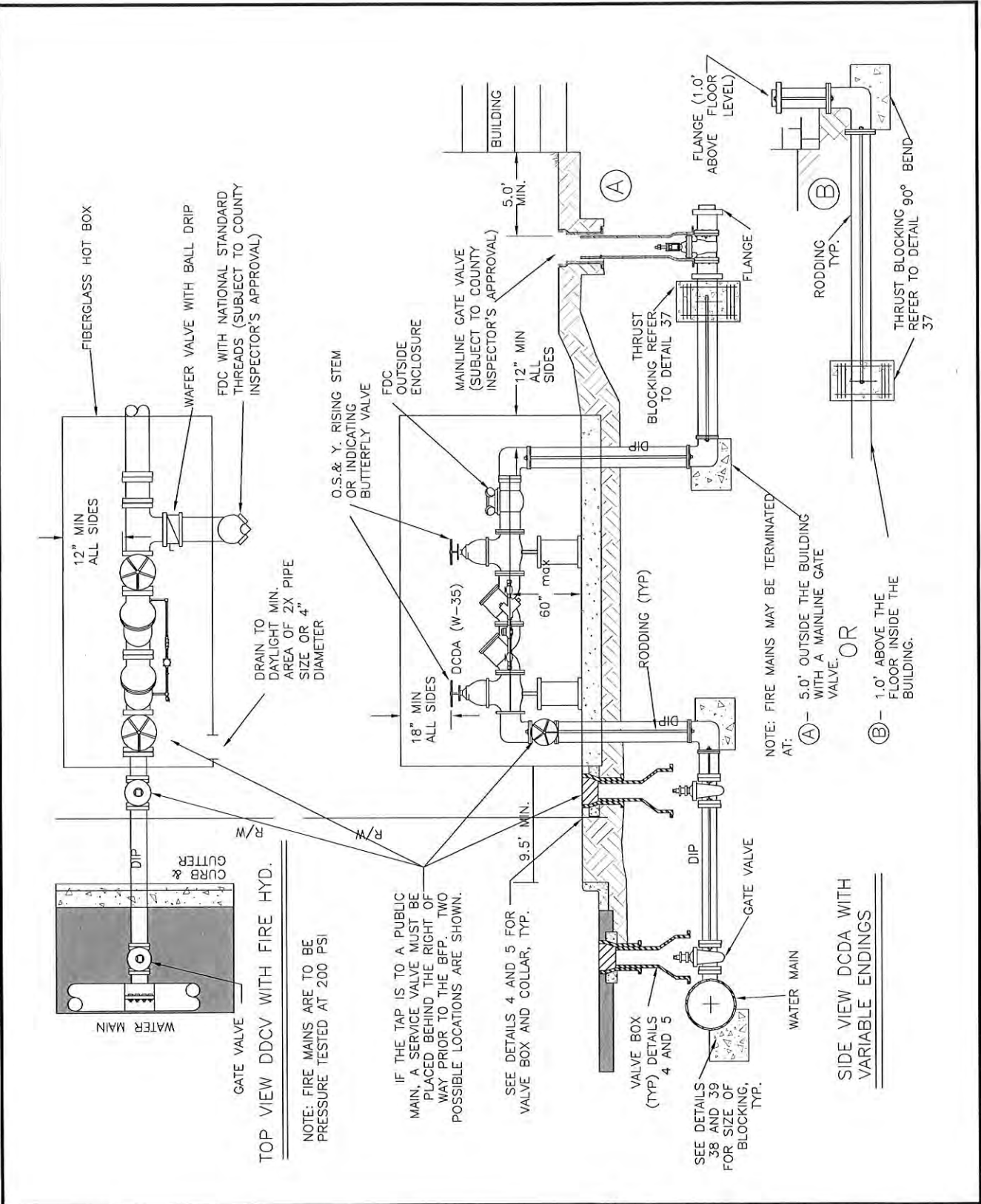

DETAIL
29
REVISION DATE
JULY 1, 2015

DOUBLE DETECTOR CHECK VALVE ASSEMBLY

**CHATHAM COUNTY
PUBLIC UTILITIES & WATER DIVISION**

P.O. BOX 910
PITTSBORO, NC 27312

694 EAST STREET, SUITE 205
PITTSBORO, NC 27312

(919) 852-8270 (BUS)
(919) 852-8282 (FAX)

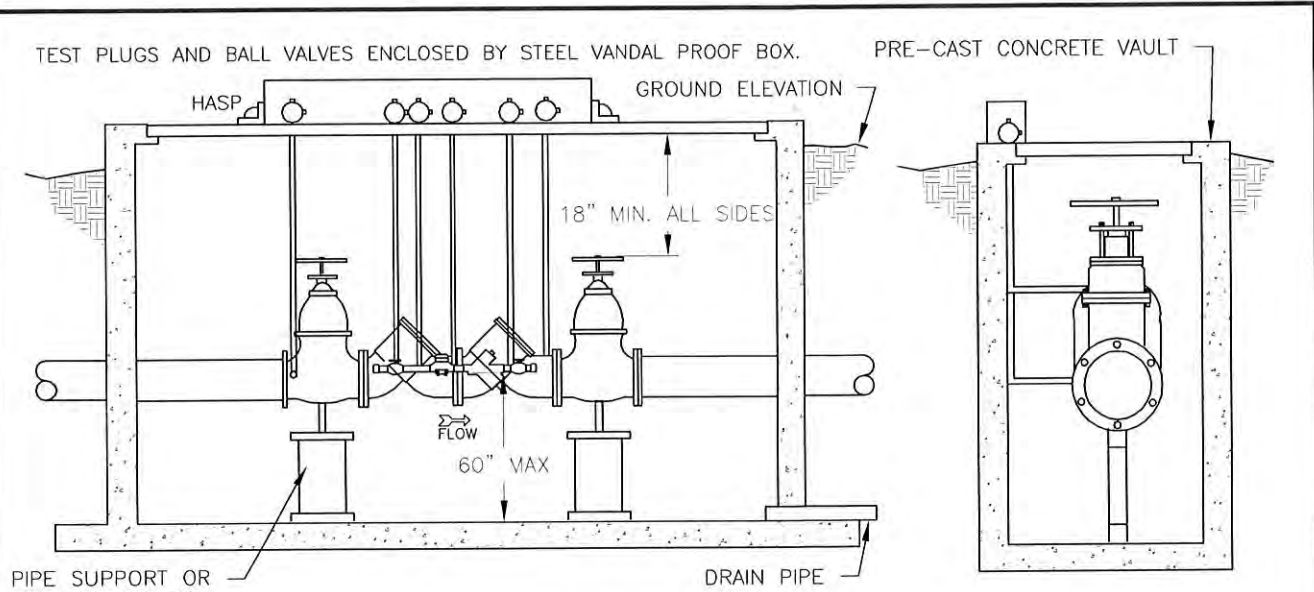

DOUBLE DETECTOR CHECK VALVE

NOTES:

1. PIPING FROM DCV OR DDCV TO TEST COCKS SHALL BE COPPER OR BRASS AND SECURED TO VAULT WALL, SMALL TEST COCKS WILL BE 3/8" COPPER.
2. STEEL VANDAL PROOF BOX ENCLOSING TEST COCKS SHALL BE A MIN. OF 18" LONG, 8" WIDE AND 4" HIGH (BOX SHALL BE INSULATED).
3. DRAIN PIPE SHALL BE 4" CORRUGATED PVC PIPE, ANIMAL PROOF, AND SHALL DRAIN TO DAYLIGHT. (IE- DITCH, GRASS, STREET OR STREAM BED).
4. ANIMAL PROOFING SHALL BE 1/2" HARDWARE CLOTH OVER END OF DRAIN, HELD IN PLACE WITH STAINLESS STEEL CLAMP.
5. LID TO VAULT SHALL BE LIGHTWEIGHT AND WATERPROOF.
6. STEPS SHALL BE INSTALLED IN THE VAULT WALL FOR EASY ACCESS TO VAULT.
7. THE LID AND TEST COCK COVER SHALL BE LOCKED WITH MATCHING LOCKS
8. TEST COCKS WILL BE NUMBERED ON THE VAULT OR THE FRAME OF TEST COCK COVER.

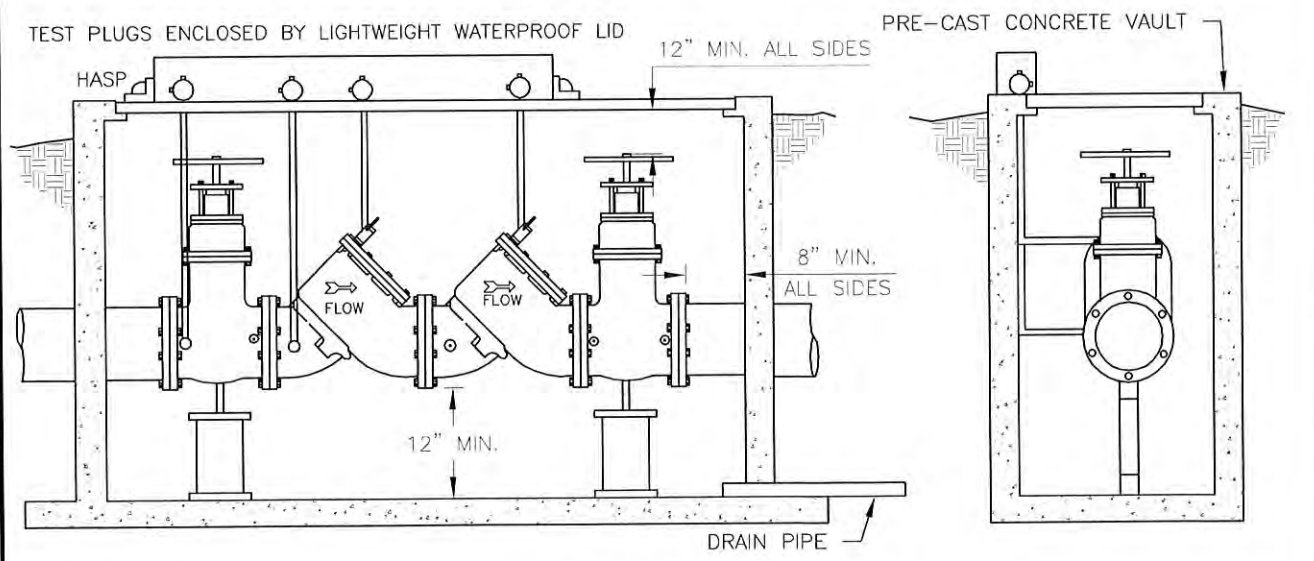

SIDE VIEW DOUBLE CHECK VALVE

DETAIL	<h2 style="margin: 0;">DOUBLE CHECK VALVE AND DOUBLE DETECTOR CHECK VALVE BELOW GROUND INSTALLATION</h2>	<p>CHATHAM COUNTY PUBLIC UTILITIES & WATER DIVISION</p> <p>P.O. BOX 910 PITTSBORO, NC 27312</p> <p>964 EAST STREET, SUITE 205 PITTSBORO, NC 27312</p> <p>(919) 852-8270 (BUS) (919) 852-8282 (FAX)</p>	
30			
REVISION DATE			
JULY 1, 2015			

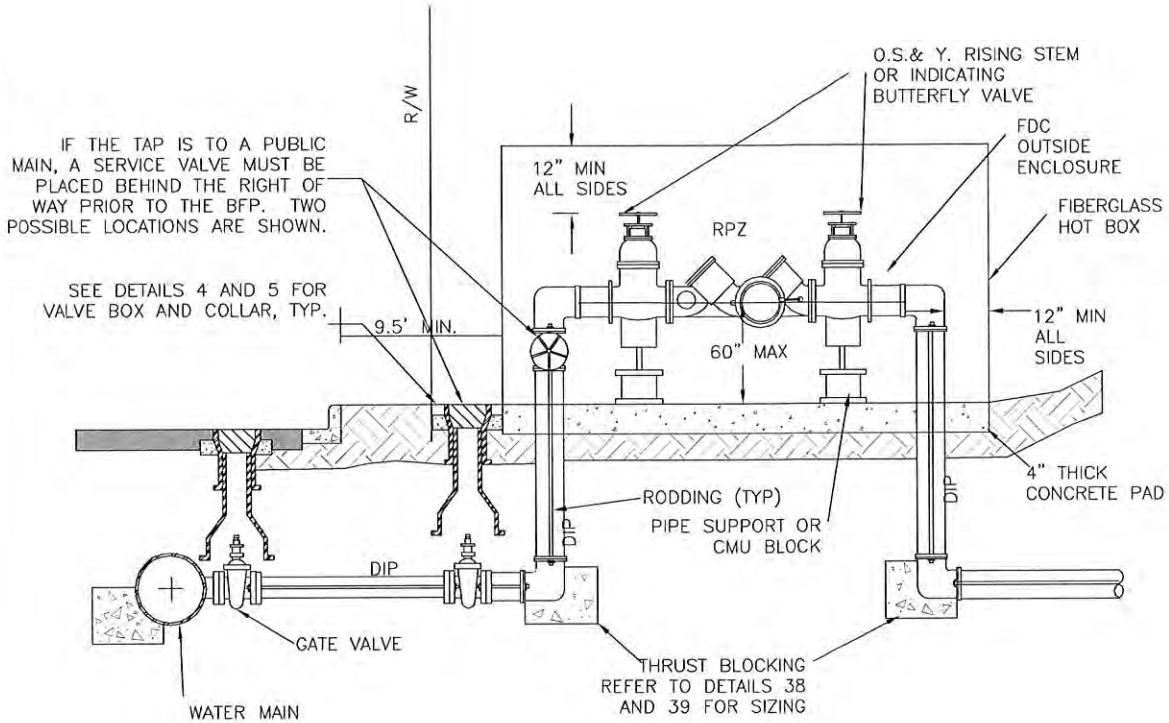

1. ALL ABOVE GROUND ENCLOSURES MUST HAVE ADEQUATE DRAINAGE (TWICE THE DIAMETER OF THE SUPPLY PIPE) TO DAYLIGHT ABOVE GRADE.
2. REDUCED PRESSURE BACKFLOW PREVENTERS MAY BE LOCATED IN A BUILDING PROVIDED THERE ARE NO OTHER UNPROTECTED TAPS BETWEEN THE MAIN AND THE BUILDING. DRAINAGE IN A BUILDING MUST BE TWICE THE DIAMETER OF THE SUPPLY PIPE.
3. ABOVE GROUND INSULATED VAULTS MUST BE ASSE 1060 APPROVED ABOVE GROUND ENCLOSURES. A CLASS I HEATED ENCLOSURE IS REQUIRED FOR ALL ASSEMBLIES.
4. RESIDENTIAL LAWN IRRIGATION R.P. ASSEMBLIES THAT ARE REMOVED TO PREVENT FREEZING IN THE WINTER MONTHS MUST BE CAPPED OFF. ALL ABOVE GROUND ASSEMBLIES, EXCEPT RESIDENTIAL LAWN IRRIGATION ASSEMBLIES, MUST BE PROTECTED FROM FROST.
5. STEEL RODS AND BOLTS SHALL BE 3/4" HOT DIPPED GALVANIZED.
6. ALL ASSEMBLIES MUST BE ON THE CURRENT APPROVAL LIST.

DETAIL	<h2>REDUCED PRESSURE ZONE BACKFLOW PREVENTER ASSEMBLY</h2>	<p>CHATHAM COUNTY PUBLIC UTILITIES & WATER DIVISION</p> <p>P.O. BOX 910 PITTSBORO, NC 27312</p> <p>964 EAST STREET, SUITE 205 PITTSBORO, NC 27312</p> <p>(919) 852-8270 (BUS) (919) 852-8282 (FAX)</p>	<p>CHATHAM COUNTY NORTH CAROLINA</p>
31			
REVISION DATE			
JULY 1, 2015			

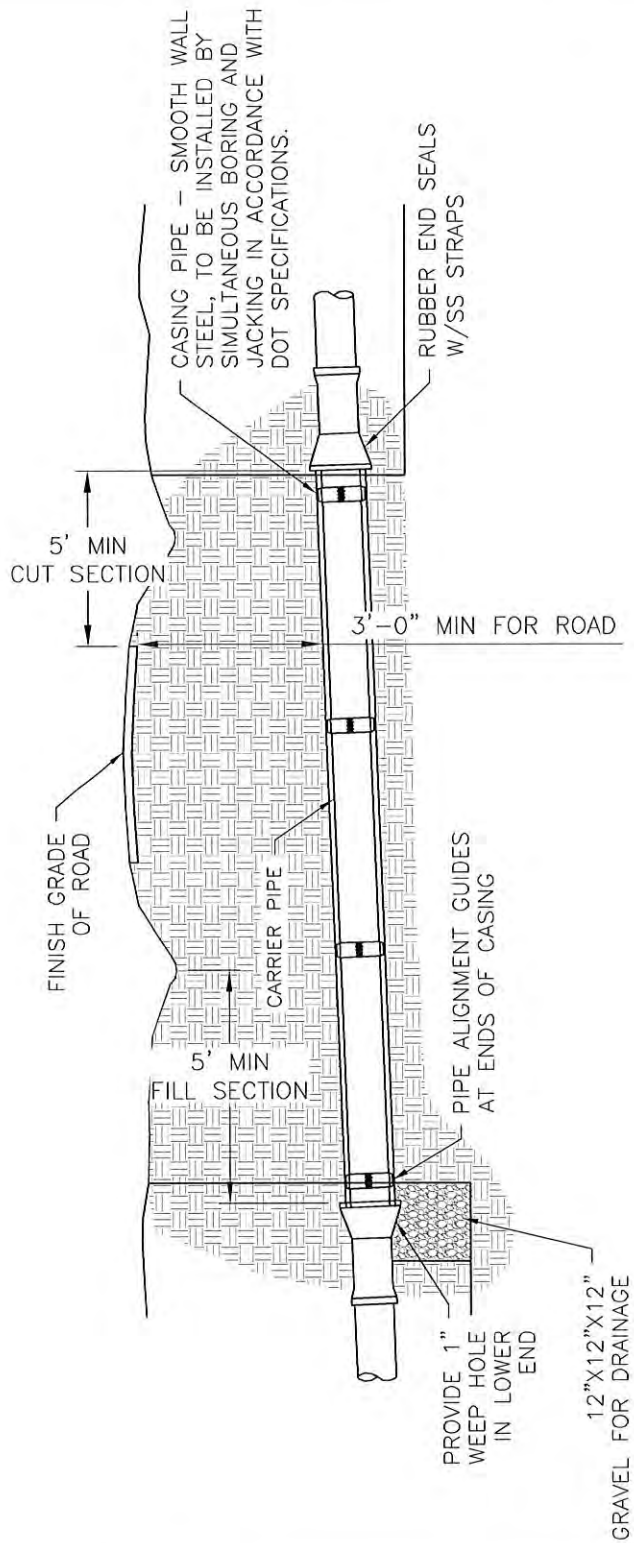

NOTES:

1. ALL BORE AND JACK INSTALLATIONS BENEATH ROADS SHALL COMPLY WITH ALL REQUIREMENTS OF THE "POLICIES AND PROCEDURES FOR ACCOMMODATING UTILITIES ON HIGHWAY RIGHTS-OF-WAY" AS PREPARED BY NCDOT.
2. CONTRACTOR SHALL COMPLY WITH ALL REQUIREMENTS OF THE "POLICIES AND PROCEDURES FOR ACCOMMODATING UTILITIES ON HIGHWAY RIGHTS-OF-WAY" AS PREPARED BY N.C.D.O.T.
3. SEE SPECIFICATION SECTION 7 FOR REQUIRED CASING PIPE SIZE AND WALL THICKNESS.

DETAIL
32
REVISION DATE
JULY 1, 2015

BORING AND SPIDER ASSEMBLY

**CHATHAM COUNTY
PUBLIC UTILITIES & WATER DIVISION**

P.O. BOX 910
PITTSBORO, NC 27312
964 EAST STREET, SUITE 205
PITTSBORO, NC 27312
(919) 852-8270 (BUS)
(919) 852-8282 (FAX)



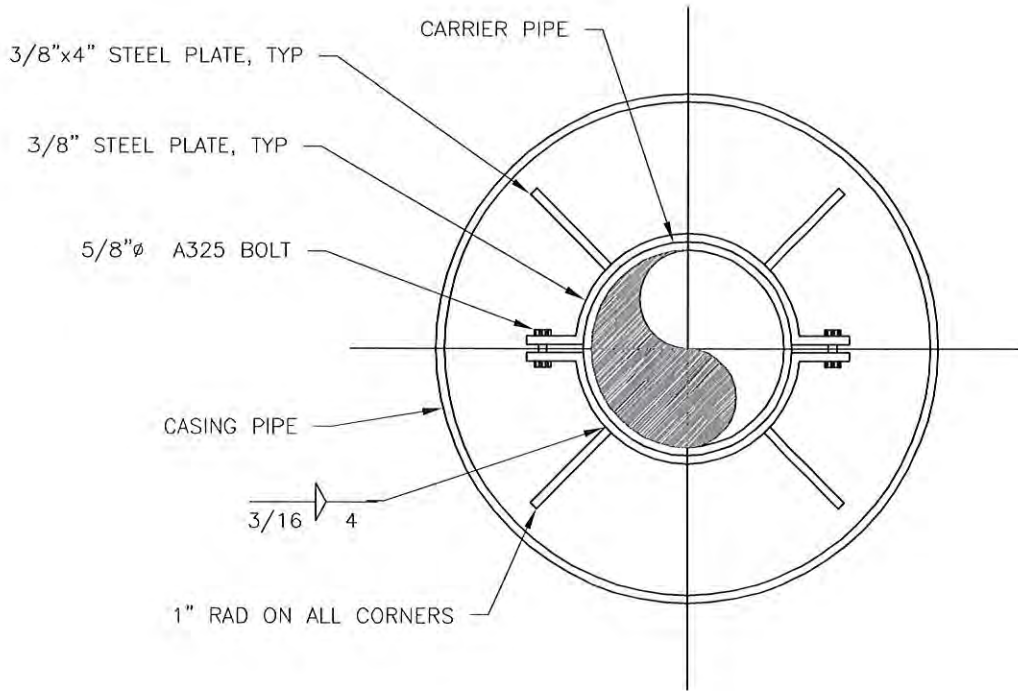

NOTE:
 USE A MINIMUM OF TWO CASING SPACERS PER PIPE JOINT ONE FOURTH OF
 THE PIPE JOINT LENGTH IN FROM BOTH THE BELL AND SPIGOT ENDS.

DETAIL	<h1>BORING PIPE ALIGNMENT GUIDE</h1>	CHATHAM COUNTY PUBLIC UTILITIES & WATER DIVISION		
<h2>33</h2>		P.O. BOX 910 PITTSBORO, NC 27312		
REVISION DATE		964 EAST STREET, SUITE 205 PITTSBORO, NC 27312		(919) 852-8270 (BUS) (919) 852-8282 (FAX)
JULY 1, 2015				

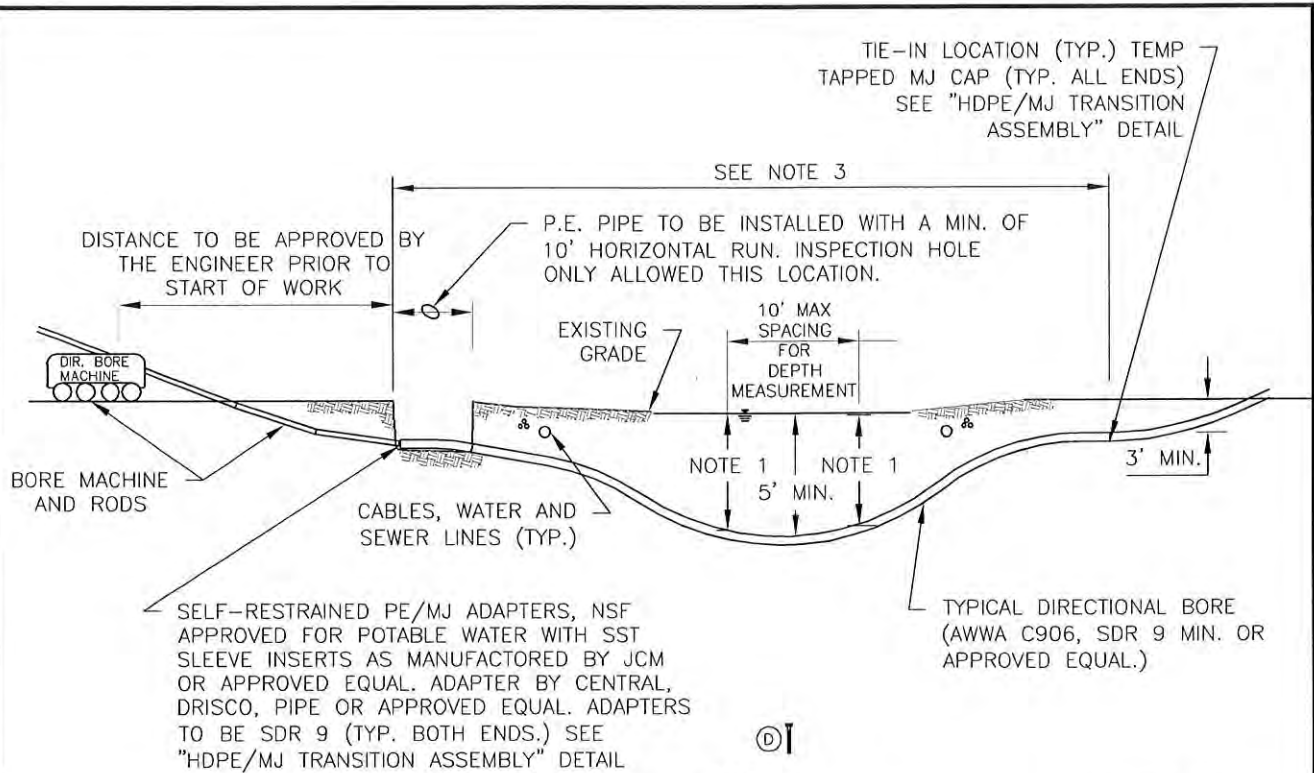

- NOTES:
1. A PLAN AND PROFILE SHALL BE PROVIDED FROM ENTRY TO EXIT FOR EACH DIRECTIONAL BORE SECTION BY THE DIRECTIONAL BORE CONTRACTOR.
 2. ALL FUSED HDPE PIPE SHALL BE AIR TESTED PRIOR TO BORING.
 3. ALL BORE SECTIONS SHALL BE HYDROSTATICALLY TESTED PER SPECIFICATION STANDARDS UPON COMPLETION OF INSTALLATION AND PRIOR TO PLACING THE WATER MAIN ON-LINE.
 4. LENGTH OF CROSSING, LOCATION OF INSPECTION/OBSERVATION EXCAVATION, NUMBER OF P.E. PIPE JOINTS, LOCATION OF BORE MACHINE, AUGER ENTRANCE LOCATION AND TIE-IN POINTS ARE TO BE APPROVED PRIOR TO ANY START OF WORK.
 5. THIS DETAIL IS ALSO APPLICABLE TO STREAMS, WETLANDS, LARGE STORM DRAINS AND SIMILAR APPLICATIONS FOR DIRECTIONAL BORE WITH POLYETHYLENE PIPE.
 6. THE BORE DEVELOPED FOR THE LEAD-IN END OF THE PIPE SHALL BE KEPT AT A MINIMUM DIAMETER FOR THE PIPE INSTALLATION. THE LEAD-IN END SHALL BE PULLED THROUGH WITHOUT THE M.J. FLANGE ATTACHED FOR LARGER THAN 6" PIPE INSTALLATIONS. THE M.J. FLANGE FOR SAID LEAD-IN END SHALL BE INSTALLED AFTER THE PIPE INSTALLATION WITH THE USE OF A SPLIT M.J. FLANGE PER THE DETAIL ON THIS DRAWING.
 7. CONTRACTOR SHALL FURNISH THE AS-BUILT LOCATION OF THE BORE IN ACCORDANCE WITH THE SPECIFICATIONS FOR DIRECTIONAL BORING.

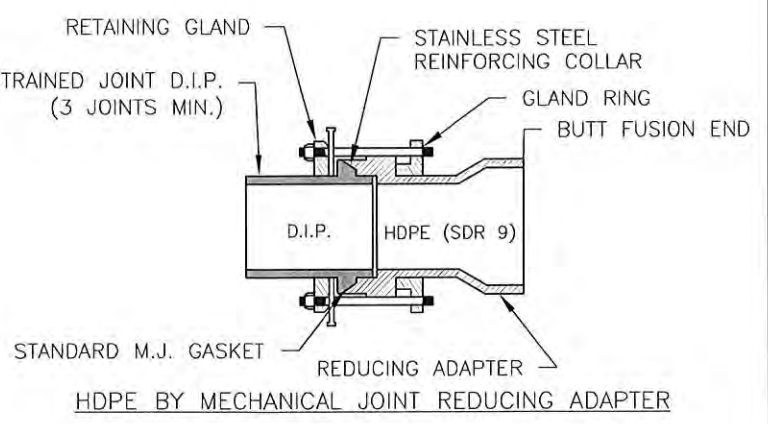
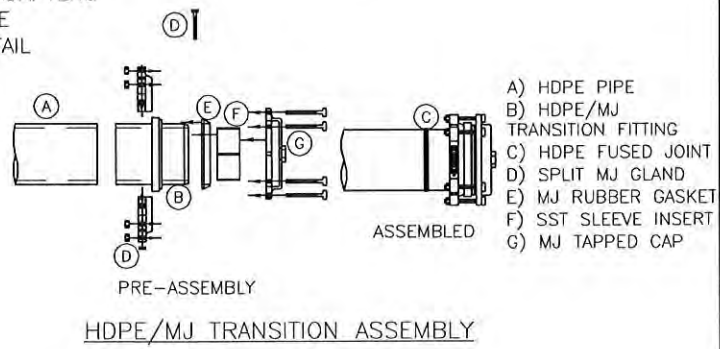

DETAIL
34
REVISION DATE
JULY 1, 2015

DIRECTIONAL BORE

CHATHAM COUNTY
PUBLIC UTILITIES & WATER DIVISION
 P.O. BOX 910
 PITTSBORO, NC 27312
 964 EAST STREET, SUITE 205
 PITTSBORO, NC 27312
 (919) 852-8270 (BUS)
 (919) 852-8282 (FAX)

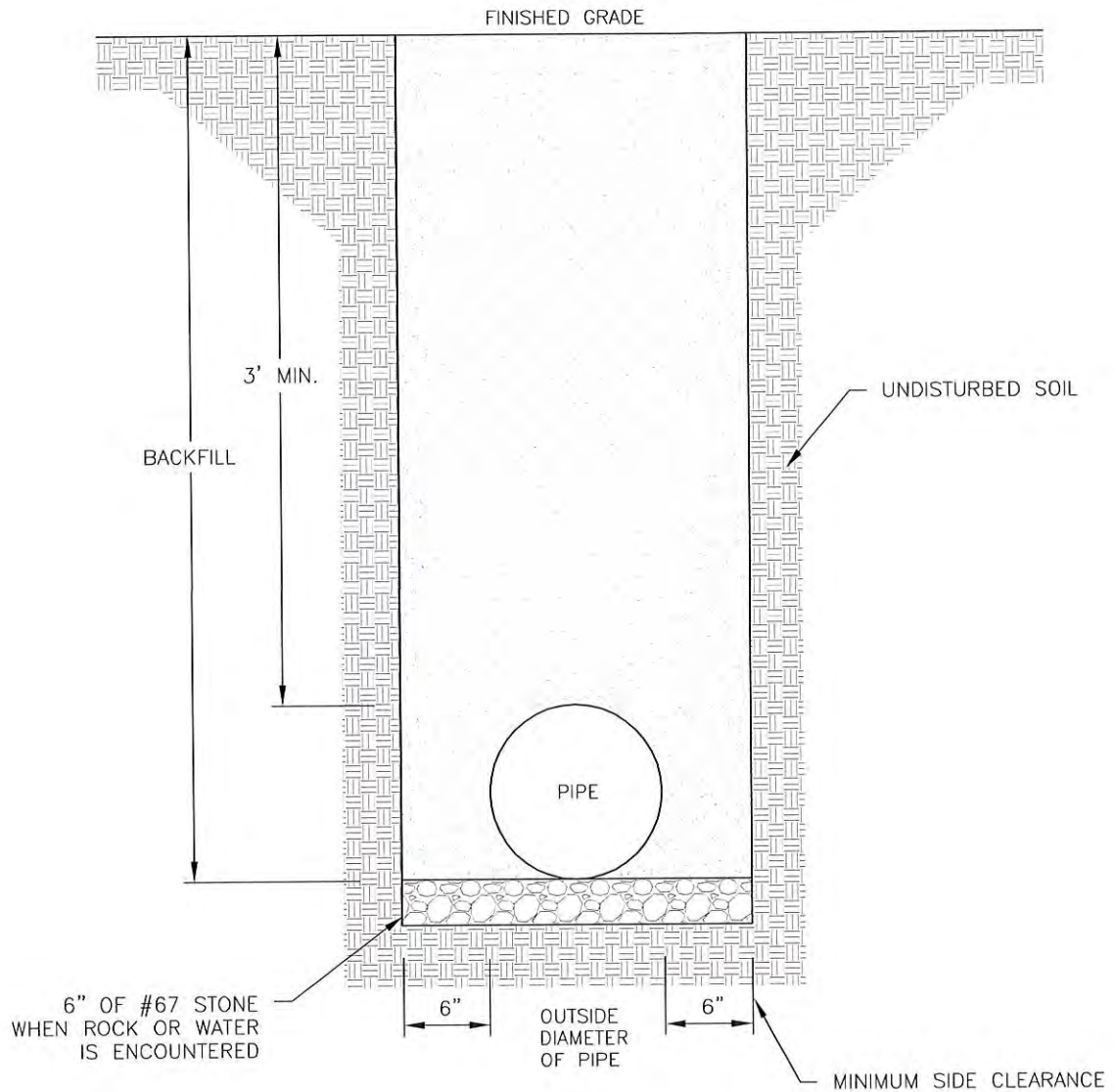

NOTES:

1. TRENCHES REQUIRING SHORING AND BRACING, DIMENSIONS SHALL BE TAKEN FROM THE INSIDE FACE OF THE SHORING AND BRACING.
2. NO ROCKS OR BOULDERS 2" OR LARGER IN DIAMETER TO BE USED IN BACKFILL.
3. ALL BACKFILL MATERIAL SHALL BE SUITABLE NATIVE MATERIAL.
4. BACKFILL SHALL BE TAMPED IN 6" LIFTS.
5. ACHIEVE 95% COMPACTION IN BACKFILL.

DETAIL	<h2 style="margin: 0;">DUCTILE IRON PIPE TRENCH BOTTOM DIMENSIONS AND BACKFILLING REQUIREMENTS</h2>	CHATHAM COUNTY PUBLIC UTILITIES & WATER DIVISION P.O. BOX 910 PITTSBORO, NC 27312 964 EAST STREET, SUITE 205 PITTSBORO, NC 27312 (919) 852-8270 (BUS) (919) 852-8282 (FAX)	
35			
REVISION DATE			
JULY 1, 2015			

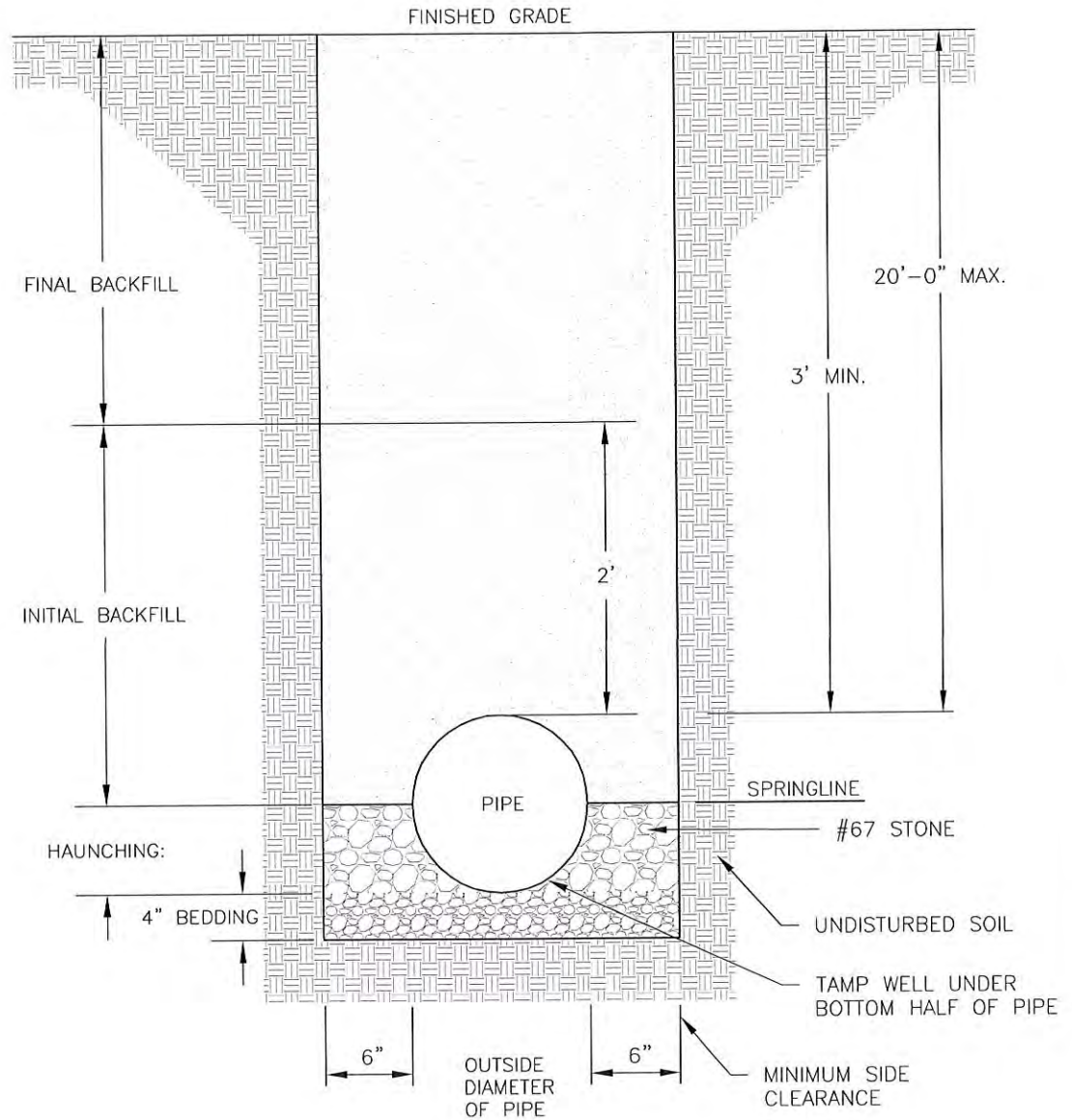

NOTES:

1. TRENCHES REQUIRING SHORING AND BRACING, DIMENSIONS SHALL BE TAKEN FROM THE INSIDE FACE OF THE SHORING AND BRACING.
2. NO ROCKS OR BOULDERS 2" OR LARGER IN DIAMETER TO BE USED IN BACKFILL.
3. ALL BACKFILL MATERIAL SHALL BE SUITABLE NATIVE MATERIAL.
4. BACKFILL SHALL BE TAMPED IN 6" LIFTS.
5. ACHIEVE 95% COMPACTION IN BACKFILL.

DETAIL	<h2 style="margin: 0;">PVC PIPE TRENCH BOTTOM DIMENSIONS AND BACKFILLING REQUIREMENTS</h2>	CHATHAM COUNTY PUBLIC UTILITIES & WATER DIVISION P.O. BOX 910 PITTSBORO, NC 27312 964 EAST STREET, SUITE 205 PITTSBORO, NC 27312 (919) 852-8270 (BUS) (919) 852-8282 (FAX)	
36			
REVISION DATE			
JULY 1, 2015			

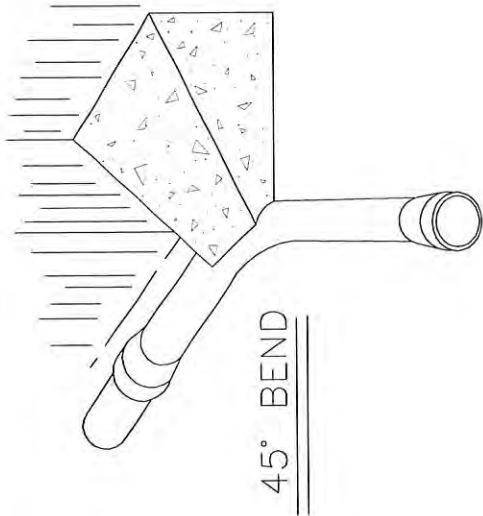

45° BEND

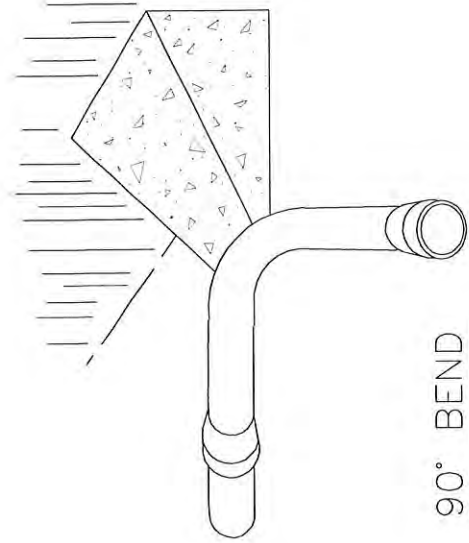

90° BEND

THRUST BLOCKING

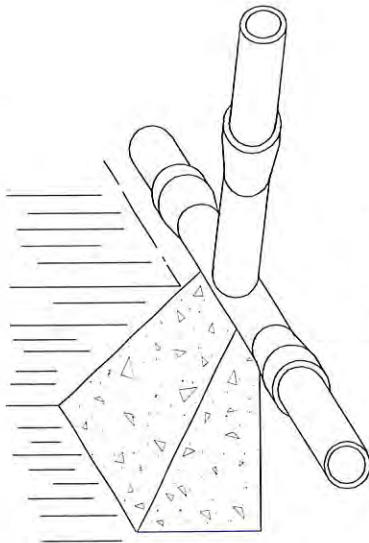

TEE INTERSECTION

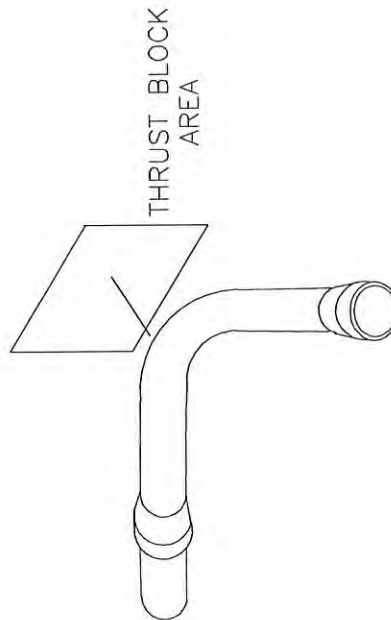

THRUST BLOCK
AREA

NOTES:

1. CONCRETE SHALL BE 3000 PSI
2. CONCRETE SHALL NOT CONTACT BOLTS OR ENDS OF MECHANICAL JOINT FITTINGS.
3. TRENCHES SHALL CONFORM TO DETAILS 35 AND 36, AS APPROPRIATE.
4. SEE STANDARD THRUST BLOCK TABLES, DETAILS 38 AND 39, FOR AREA OF CONCRETE REQUIRED.
5. ALL BENDS AND INTERSECTIONS SHALL HAVE CONCRETE THRUST BLOCKING.

DETAIL
37
REVISION DATE
JULY 1, 2015

**STANDARD THRUST
BLOCKING VIEWS**

CHATHAM COUNTY
PUBLIC UTILITIES & WATER DIVISION

P.O. BOX 910
PITTSBORO, NC 27312
964 EAST STREET, SUITE 205
PITTSBORO, NC 27312
(919) 852-8270 (BUS)
(919) 852-8282 (FAX)



REACTION BEARING AREAS FOR HORIZONTAL WATER PIPE BENDS
 BASED ON TEST PRESSURE OF 200 P.S.I.

ALL AREAS GIVEN IN SQUARE FEET.

SIZE AND DEGREE OF BEND	STATIC THRUST IN POUNDS	MODERATELY DRY CLAY 4000 LBS/FT ²	SOFT CLAY 2000 LBS/FT ²	GRAVEL / COARSE SAND 1600 LBS/FT ²	DRY CLAY - ALWAYS DRY 8000 LBS/FT ²	SAND, COMPACT FIRM 8000 LBS/FT ²	SAND - CLEAN DRY 4000 LBS/FT ²	QUICKSAND - VERY POOR SOIL 1000 LBS/FT ²	ROCK - POOR 10,000 LBS/FT ²
6"									
11 1/4°	1,108	1	1	1	1	1	2	1	
22 1/2°	2,207	1	2	2	1	1	3	1	
45°	4,328	2	3	3	1	1	5	1	
90°	7,996	2	4	5	1	1	8	1	
PLUG	5,655	2	3	4	1	1	6	1	
8"									
11 1/4°	1,970	1	1	2	1	1	2	1	
22 1/2°	3,922	1	2	3	1	1	4	1	
45°	7,694	2	4	5	1	1	8	1	
90°	14,215	4	8	9	2	2	15	2	
PLUG	10,053	3	5	6	2	2	10	1	
12"									
11 1/4°	4,433	2	3	3	1	1	5	1	
22 1/2°	8,826	3	5	6	2	2	9	1	
45°	17,312	5	9	11	3	3	18	2	
90°	31,983	8	16	19	4	4	32	4	
PLUG	22,619	6	12	14	3	3	23	3	
16"									
11 1/4°	7,881	2	4	5	1	1	8	1	
22 1/2°	15,691	4	8	10	2	2	16	2	
45°	30,779	8	16	19	4	4	31	4	
90°	56,861	15	29	35	8	8	57	6	
PLUG	40,213	10	21	25	5	5	41	5	

REACTION BEARING AREAS ARE IN SQUARE FEET MEASURED IN A VERTICAL PLANE IN THE TRENCH SIDE AT AN ANGLE OF 90° TO THE THRUST VECTOR.
 USE 6" - 90 DEGREE BEND VALUE FOR HYDRANTS FOR ADDITIONAL SAFETY FACTOR.

DETAIL
38
REVISION DATE
JULY 1, 2015

**CONCRETE THRUST
 BLOCKING QUANTITY TABLE,
 6" - 16" PIPE**

CHATHAM COUNTY
 PUBLIC UTILITIES & WATER DIVISION

P.O. BOX 910
 PITTSBORO, NC 27312
 964 EAST STREET, SUITE 205
 PITTSBORO, NC 27312
 (919) 852-8270 (BUS)
 (919) 852-8282 (FAX)



REACTION BEARING AREAS FOR HORIZONTAL WATER PIPE BENDS
 BASED ON TEST PRESSURE OF 200 P.S.I.

ALL AREAS GIVEN IN SQUARE FEET.

SIZE AND DEGREE OF BEND	STATIC THRUST IN POUNDS	MODERATELY DRY CLAY 4000 LBS/FT ²	SOFT CLAY 2000 LBS/FT ²	GRAVEL/COARSE SAND 1600 LBS/FT ²	DRY CLAY - ALWAYS DRY 800 LBS/FT ²	SAND, COMPACT FIRM 800 LBS/FT ²	SAND - CLEAN DRY 4000 LBS/FT ²	QUICKSAND - VERY POOR SOIL 1000 LBS/FT ²	ROCK - POOR 10,000 LBS/FT ²
24"									
11 1/4'	17,734	5	9	11	3	3	5	18	2
22 1/2'	35,305	9	18	22	5	5	9	36	4
45°	69,252	18	35	42	9	9	18	70	7
90°	127,936	32	64	77	16	16	32	128	13
PLUG	90,478	23	46	55	12	12	23	91	10
30"									
11 1/4'	27,709	7	14	17	4	4	7	2	3
22 1/2'	55,163	14	28	34	7	7	14	56	6
45°	108,206	28	55	65	14	14	28	109	11
90°	199,900	50	100	120	25	25	50	200	20
PLUG	141,372	36	71	85	18	18	36	142	15
36"									
11 1/4'	39,901	10	20	24	5	5	10	40	4
22 1/2'	79,439	20	40	48	10	10	20	30	8
45°	155,816	39	78	94	20	20	39	156	16
90°	287,855	72	144	172	36	36	72	288	29
PLUG	203,575	51	102	122	26	26	51	204	21
48"									
11 1/4'	70,935	18	36	43	9	9	18	71	8
22 1/2'	141,218	36	71	85	18	18	36	142	15
45°	277,007	70	139	166	35	35	70	277	28
90°	511,742	128	256	320	64	64	128	512	52
PLUG	361,911	91	181	217	46	46	91	362	37

REACTION BEARING AREAS ARE IN SQUARE FEET MEASURED IN A VERTICAL PLANE IN THE TRENCH SIDE AT AN ANGLE OF 90° TO THE THRUST VECTOR.
 USE 6" - 90 DEGREE BEND VALUE FOR HYDRANTS FOR ADDITIONAL SAFETY FACTOR.

DETAIL	CONCRETE THRUST BLOCKING QUANTITY TABLE, 24" - 48" PIPE	CHATHAM COUNTY PUBLIC UTILITIES & WATER DIVISION P.O. BOX 910 PITTSBORO, NC 27312 964 EAST STREET, SUITE 205 PITTSBORO, NC 27312 (919) 852-8270 (BUS) (919) 852-8282 (FAX)	
39			
REVISION DATE			
JULY 1, 2015			

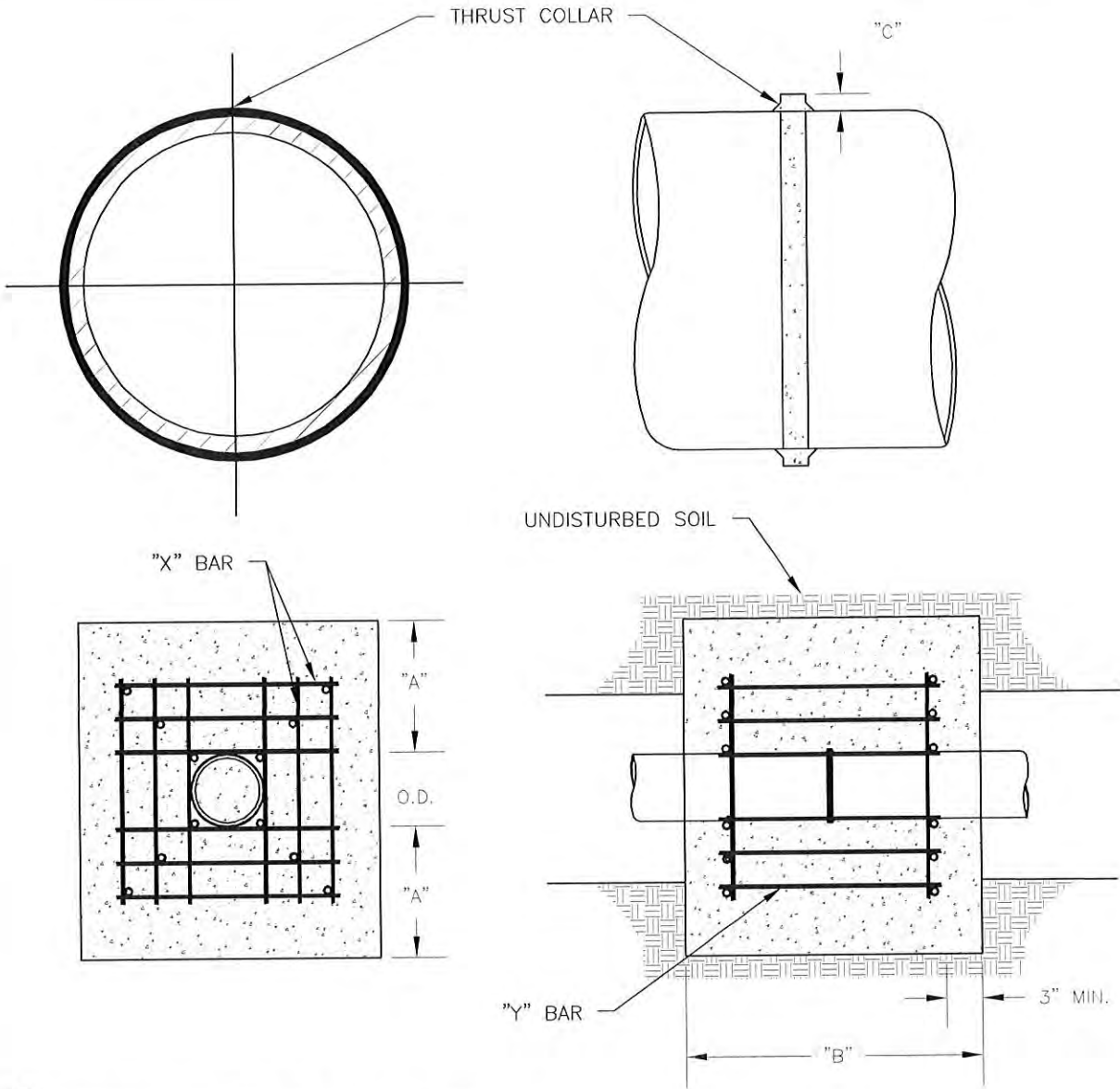

- NOTES:
1. CONCRETE SHALL BE 3000 PSI AND TRANSIT MIXED.
 2. REINFORCING BARS SHALL BE DEFORMED AND TIED TOGETHER.
 3. THRUST COLLAR MUST BE FACTORY WELDED ON BOTH SIDES ALONG BOTH EDGES OF COLLAR AROUND CIRCUMFERENCE.

REINFORCING REQUIREMENTS

I.D. PIPE	REBAR SIZE	"X" BAR LENGTH	"X" BAR WEIGHT	"Y" BAR LENGTH	"Y" BAR WEIGHT	NO. REQUIRED
6" - 36"	#5	2'-2"+ O.D. PIPE	1.043 LBS/FT	1'-1"	1.1 LBS. EACH	X-24, Y-12
48" & GREATER	#6	3'-0"+ O.D. PIPE	1.502 LBS/FT	1'-3"	1.9 LBS. EACH	X-24, Y-12

THRUST COLLAR AND THRUST SCHEDULE

I.D. PIPE	"A"	"B"	"C-6"-16"	20"-24"	30"-36"	48"
6" - 36"	1'-4"	1'-7"	2"	3"	4"	
48" & GREATER	1'-8"	1'-9"				6"

DETAIL
40
REVISION DATE
JULY 1, 2015

CONCRETE THRUST BLOCKING FOR WATER MAINS

CHATHAM COUNTY
PUBLIC UTILITIES & WATER DIVISION
P.O. BOX 910
PITTSBORO, NC 27312
964 EAST STREET, SUITE 205
PITTSBORO, NC 27312
(919) 852-8270 (BUS)
(919) 852-8282 (FAX)



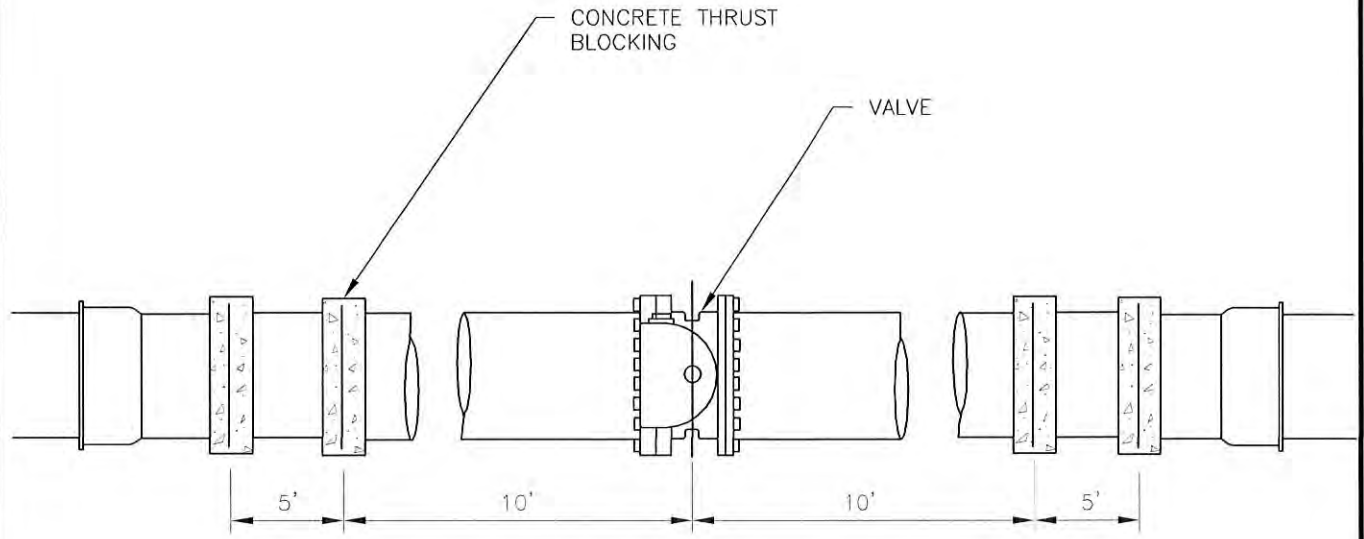

NOTE:
 1. 16" OR SMALLER MAIN – 1 THRUST BLOCK REQUIRED
 2. GREATER THAN 16" – 2 THRUST BLOCKS REQUIRED

DETAIL	<h2>CONCRETE THRUST BLOCKING FOR VALVES AND DEAD ENDS</h2>	CHATHAM COUNTY PUBLIC UTILITIES & WATER DIVISION	
41		P.O. BOX 910 PITTSBORO, NC 27312	
REVISION DATE		964 EAST STREET, SUITE 205 PITTSBORO, NC 27312	
JULY 1, 2015		(919) 852-8270 (BUS) (919) 852-8282 (FAX)	

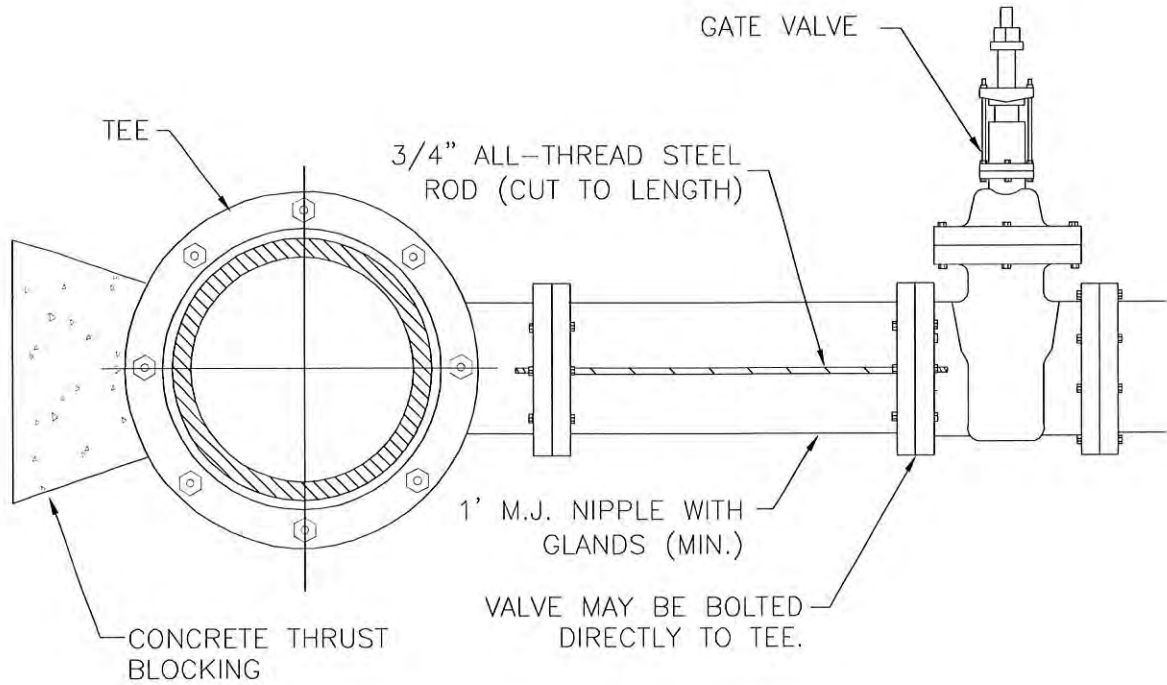

ROD REQUIREMENTS	
BRANCH SIZE	NO. OF RODS
4"	2
6"	2
8"	4
12"	4
16"	6
24"	6
30"	8
36"	8

NOTES:

1. STEEL RODS AND BOLTS SHALL BE 3/4" HOT DIPPED GALVANIZED.
2. CONCRETE SHALL NOT CONTACT BOLTS OR ENDS OF MECHANICAL FITTINGS.
3. THIS RODDING REQUIREMENT DOES NOT APPLY TO FIRE HYDRANTS.
4. SEE DETAILS 38 AND 39 FOR THRUST BLOCK SIZING.

DETAIL	<h2 style="margin: 0;">4" - 24" RESTRAINED TEE AND VALVE ON DEAD ENDS</h2>	CHATHAM COUNTY PUBLIC UTILITIES & WATER DIVISION	
42		P.O. BOX 910 PITTSBORO, NC 27312	
REVISION DATE		964 EAST STREET, SUITE 205 PITTSBORO, NC 27312	
JULY 1, 2015		(919) 852-8270 (BUS) (919) 852-8282 (FAX)	

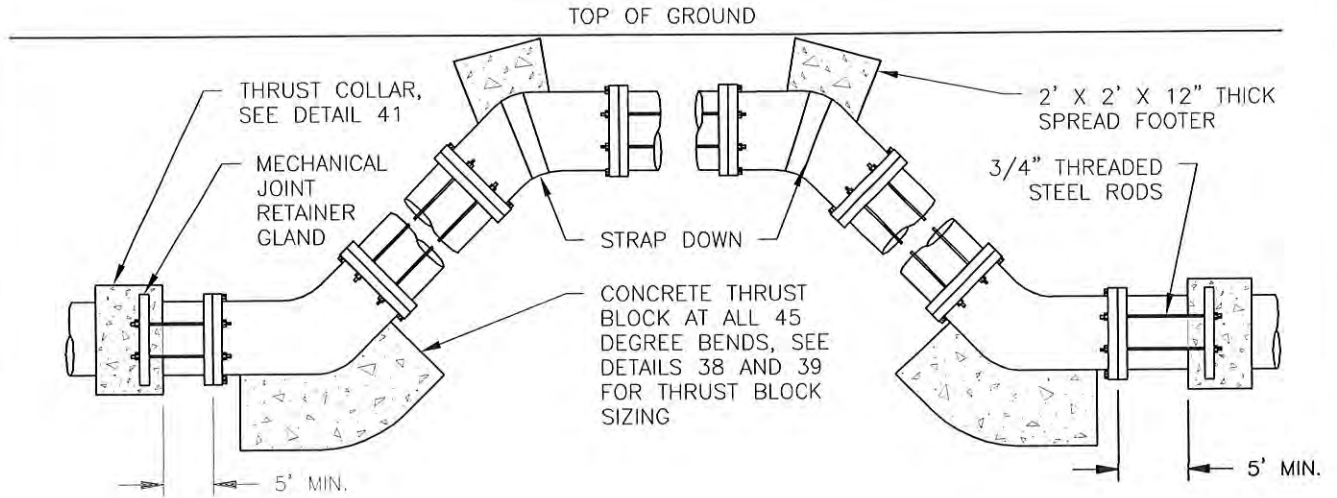

ROD REQUIREMENTS

SIZE OF 45 DEGREE BEND	STATIC THRUST IN POUNDS	NO. OF RODS REQUIRED
6"	4,328	2
8"	7,694	4
12"	17,312	4
16"	30,779	8
24"	69,252	8

NOTES:

1. STEEL RODS AND BOLTS SHALL BE 3/4" HOT DIPPED GALVANIZED.
2. CONCRETE SHALL NOT CONTACT BOLTS OR ENDS OF MECHANICAL JOINT BENDS.
3. RESTRAINED MECHANICAL GLANDS TO BE USED AT ALL FITTINGS.
4. MUST USE DUCTILE IRON EYE BOLTS WHERE NECESSARY.
5. ADD MECHANICAL JOINT RETAINER GLANDS THROUGHOUT ASSEMBLY.
6. 3' MINIMUM COVER MUST BE MAINTAINED ON ALL WATER MAINS

DETAIL	<h2 style="margin: 0;">VERTICAL BEND ASSEMBLY</h2>	CHATHAM COUNTY PUBLIC UTILITIES & WATER DIVISION
43		P.O. BOX 910 PITTSBORO, NC 27312
REVISION DATE		964 EAST STREET, SUITE 205 PITTSBORO, NC 27312
JULY 1, 2015		(919) 852-8270 (BUS) (919) 852-8282 (FAX)



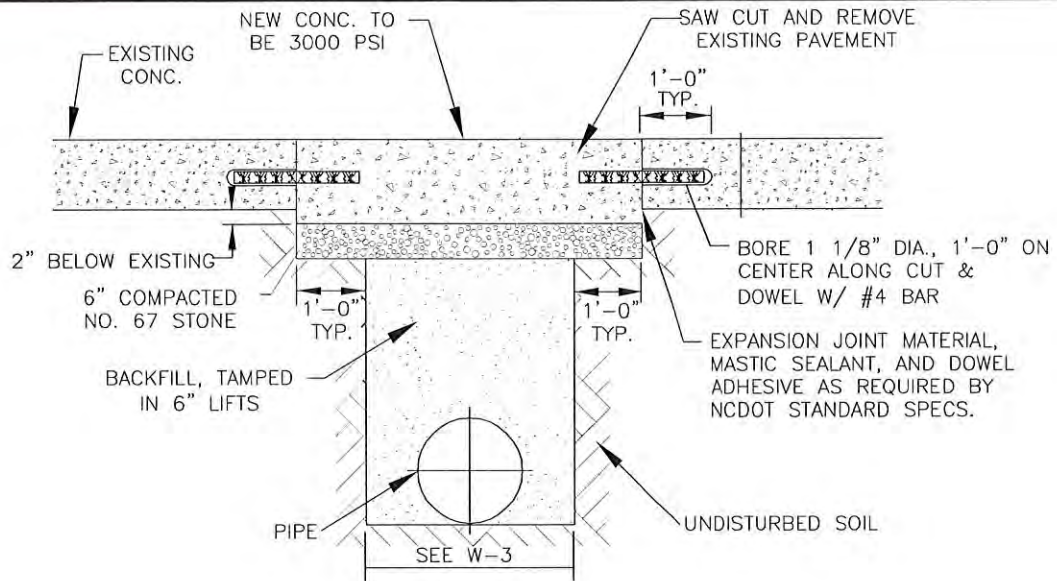

NOTES FOR ASPHALT AND CONCRETE:

1. THE PAVEMENT CUT SHALL BE DEFINED BY A STRAIGHT EDGE AND CUT WITH AN APPROPRIATE SAW CUT MACHINE.
2. SUBGRADE MATERIAL SHALL BE COMPACTED TO A DENSITY OF 95% IN ACCORDANCE WITH AASHTO T-99 AS MODIFIED BY NCDOT.
3. THE FINAL 6" (CONCRETE) OR 12" (ASPHALT) OF FILL SHALL CONSIST OF ABC MATERIAL COMPACTED TO A DENSITY OF 100% IN ACCORDANCE WITH AASHTO T-80 AS MODIFIED BY NCDOT.

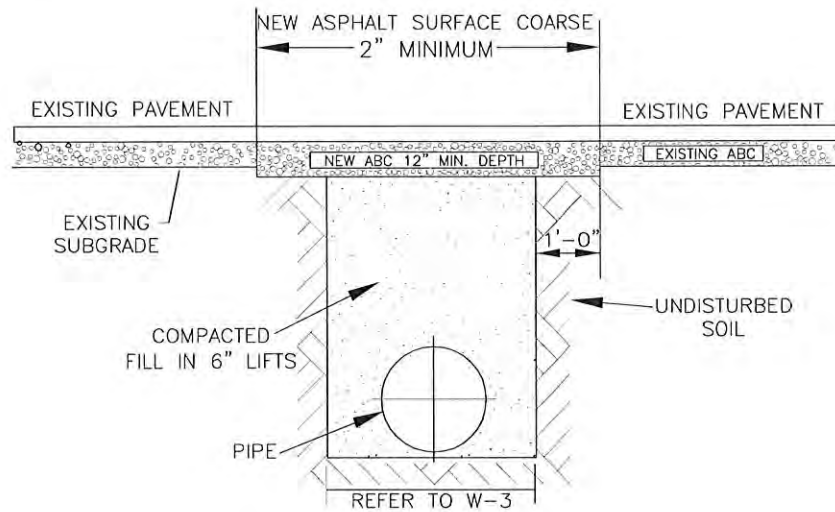

NOTES FOR ASPHALT ONLY:

1. THE ENTIRE THICKNESS/VERTICAL EDGE OF CUT SHALL BE TACKED.
2. THE SAME DEPTH OF PAVEMENT MATERIAL WHICH EXISTS SHALL BE REINSTALLED OR A MINIMUM 3" THICK.
3. THE ASPHALT SHALL BE INSTALLED AND COMPACTED THOROUGHLY WITH A SMOOTH DRUM ROLLER TO ACHIEVE A SMOOTH LEVEL PATCH.
4. NO HAND PATCHING ALLOWED.
5. PAVEMENT CUTS WITHIN NCDOT ROW SHALL CONFORM TO THE APPROVED ON SITE ENCROACHMENT PERMIT.

DETAIL	<h1>CONCRETE AND ASPHALT OPEN CUT AND PATCH</h1>	CHATHAM COUNTY PUBLIC UTILITIES & WATER DIVISION	
44		P.O. BOX 910 PITTSBORO, NC 27312	
REVISION DATE		964 EAST STREET, SUITE 205 PITTSBORO, NC 27312	
JULY 1, 2015		(919) 852-8270 (BUS) (919) 852-8282 (FAX)	

NOTE: NO ENCASEMENT REQUIRED FOR SPACE
GREATER THAN 18" FOR WATER LINES

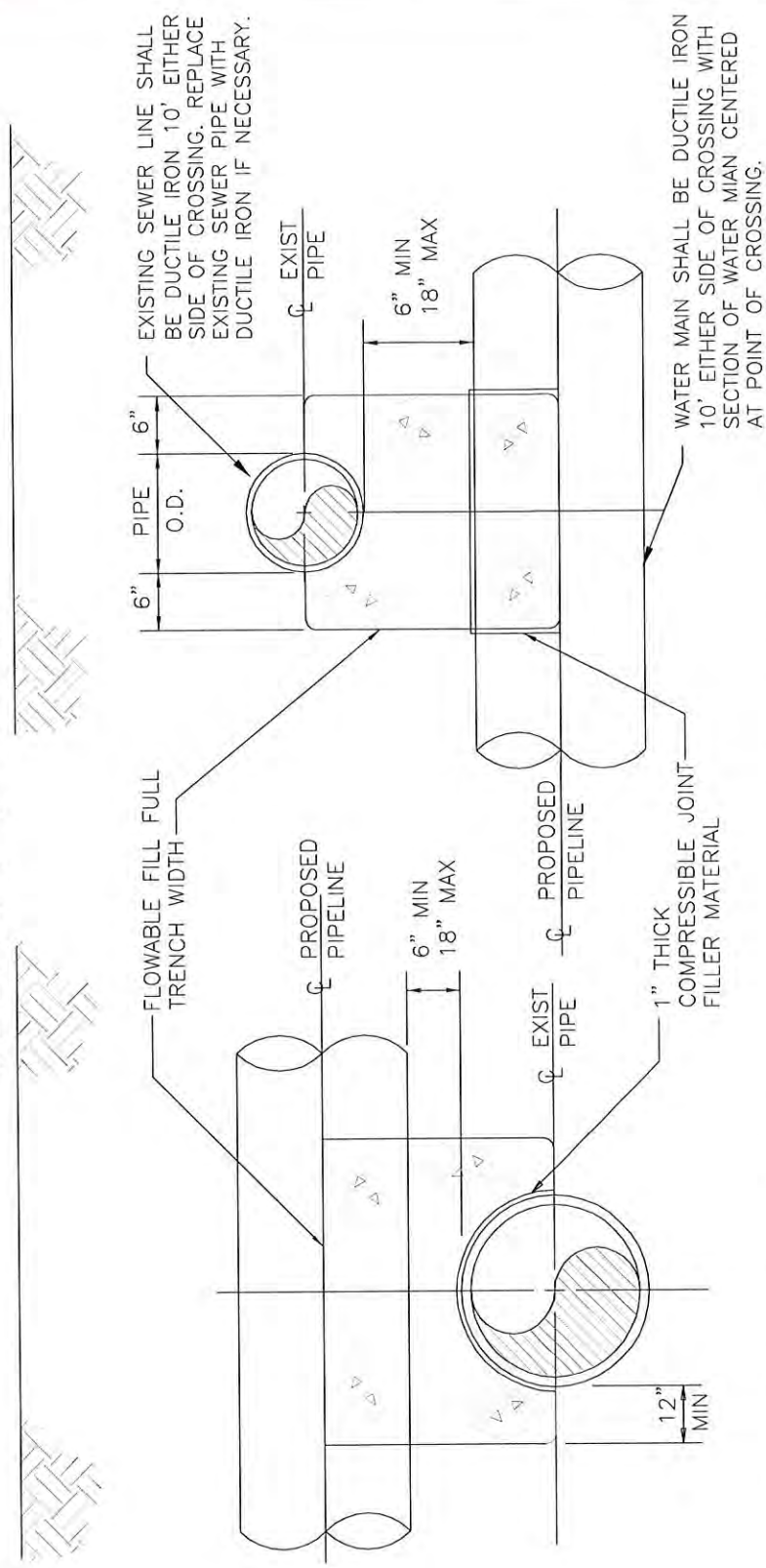

DETAIL
45
REVISION DATE
JULY 1, 2015

WATER AND SEWER CROSSING

CHATHAM COUNTY
PUBLIC UTILITIES & WATER DIVISION

P.O. BOX 910
PITTSBORO, NC 27312
964 EAST STREET, SUITE 205
PITTSBORO, NC 27312
(919) 852-8270 (BUS)
(919) 852-8282 (FAX)



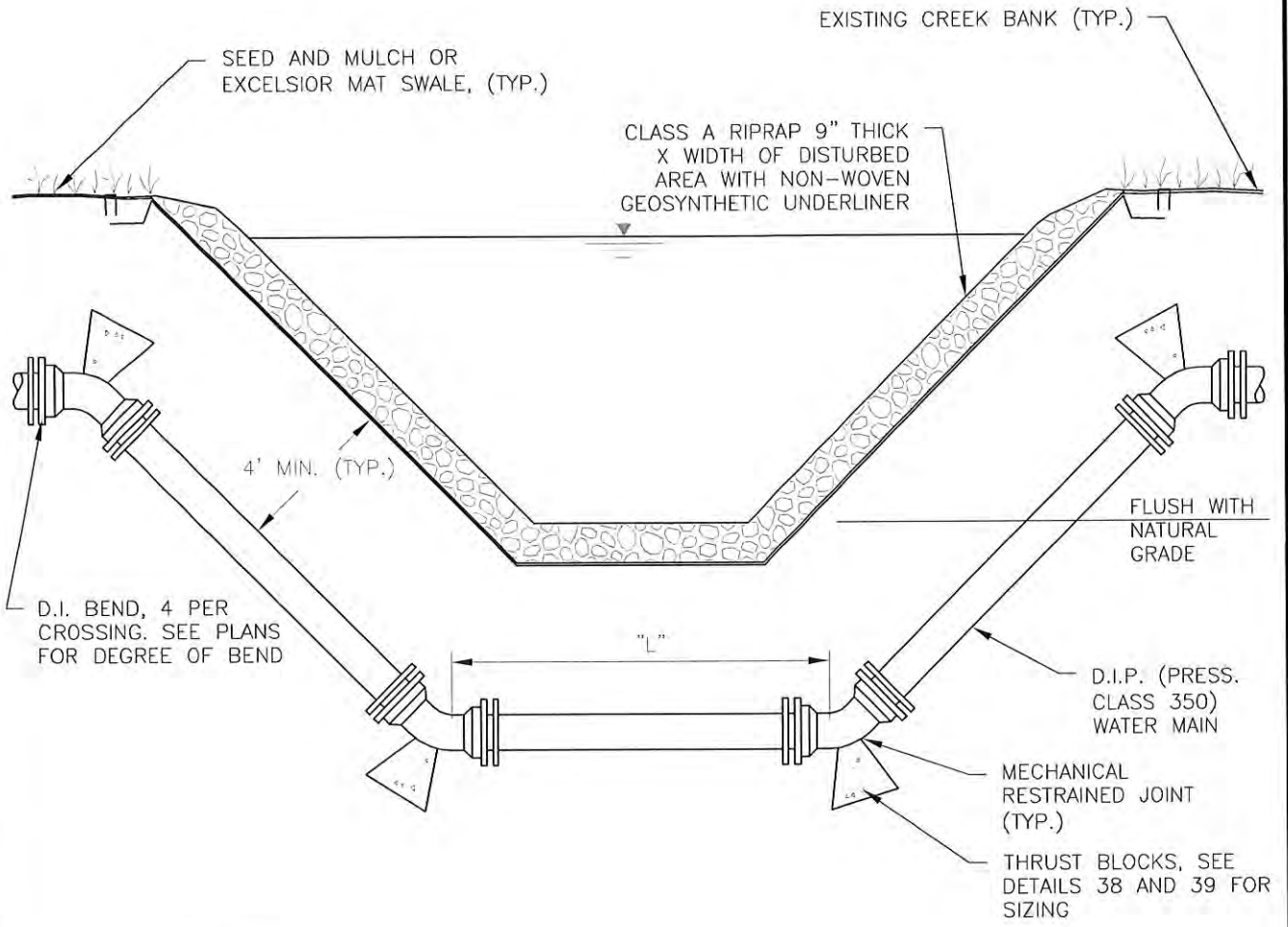

NOTES:

1. PROVIDE "L" TO MAINTAIN 3' MIN. COVER UNDER CREEK AND AT BOTH BANKS.
2. MATCH EXISTING BANK SLOPE.
3. UNIFORM FLOW IN THE STREAM SHALL BE MAINTAINED DURING THE "WET" STREAM CROSSING.
4. CONTRACTOR SHALL PLACE TEMPORARY PIPING IN THE STREAM BED, CENTERED AT THE CROSSING, OF SUFFICIENT LENGTH AND DIAMETER TO CREATE A TEMPORARY FLUME WHICH WILL EFFECTIVELY TRANSPORT THE STREAM FLOW DURING THE PERIOD OF WATER MAIN INSTALLATION.
5. CONTRACTOR SHALL REMOVE FLUME PIPING AND INSTALL STREAM BANK STABILIZATION MEASURES IMMEDIATELY FOLLOWING WATER MAIN INSTALLATION.

DETAIL	<h2>STREAM CROSSING AND BANK STABILIZATION</h2>	CHATHAM COUNTY PUBLIC UTILITIES & WATER DIVISION
46		P.O. BOX 910 PITTSBORO, NC 27312
REVISION DATE		964 EAST STREET, SUITE 205 PITTSBORO, NC 27312
JULY 1, 2015		(919) 852-8270 (BUS) (919) 852-8282 (FAX)
		 CHATHAM COUNTY NORTH CAROLINA

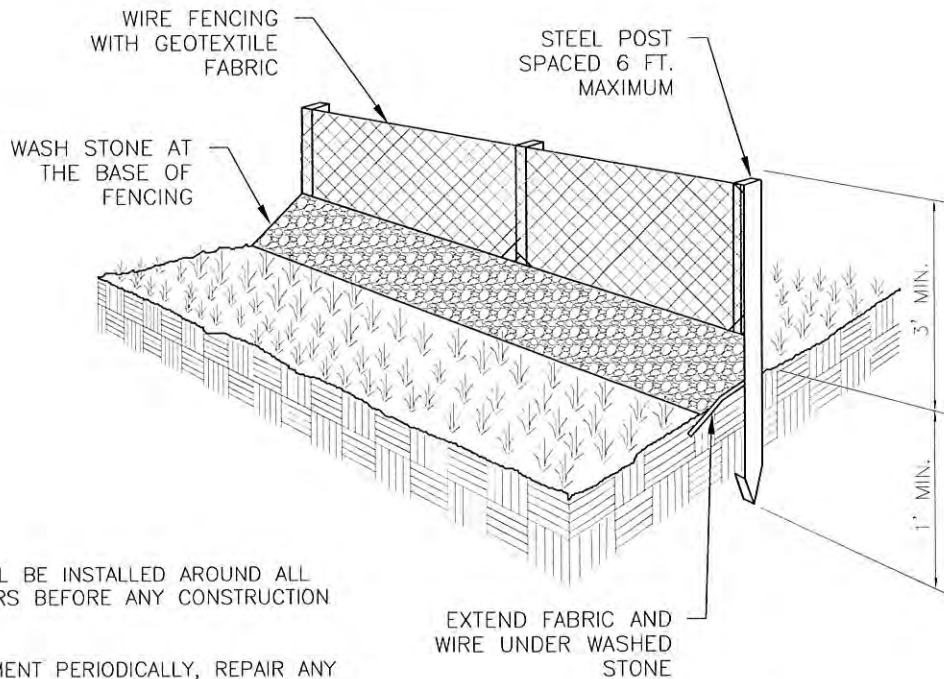

NOTES:

- 1) FENCING SHALL BE INSTALLED AROUND ALL EXISTING METERS BEFORE ANY CONSTRUCTION STARTS
- 2) REMOVE SEDIMENT PERIODICALLY, REPAIR ANY UNDERMINING IMMEDIATELY

NOTES:

- 1) FENCING SHALL BE 5' MINIMUM AROUND METER
- 2) FAUCET SHALL BE 10' MINIMUM FROM METER BOX
- 3) FENCING SHALL BE INSPECTED AND APPROVED BEFORE CONSTRUCTION STARTS

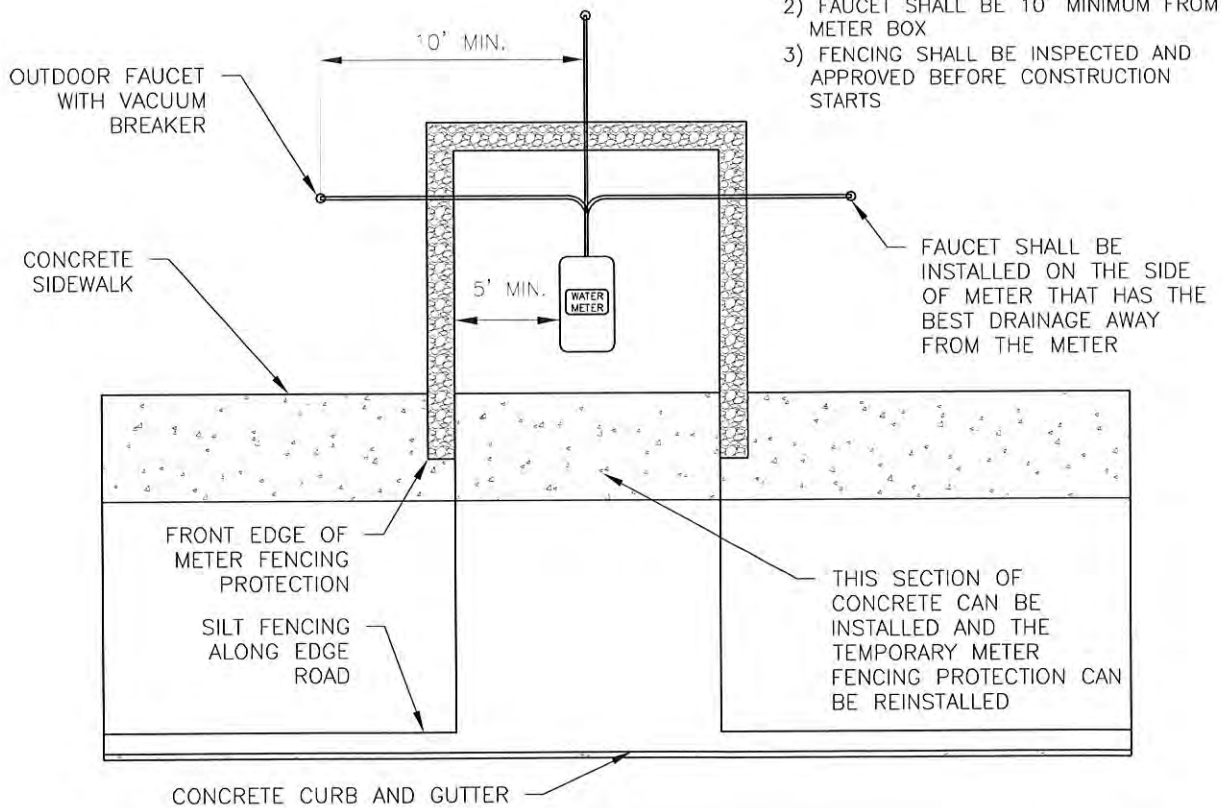

DETAIL
47
REVISION DATE
JULY 1, 2015

TEMPORARY METER FENCING PROTECTION

**CHATHAM COUNTY
PUBLIC UTILITIES & WATER DIVISION**

P.O. BOX 910
PITTSBORO, NC 27312
964 EAST STREET, SUITE 205
PITTSBORO, NC 27312
(919) 852-8270 (BUS)
(919) 852-8282 (FAX)

